

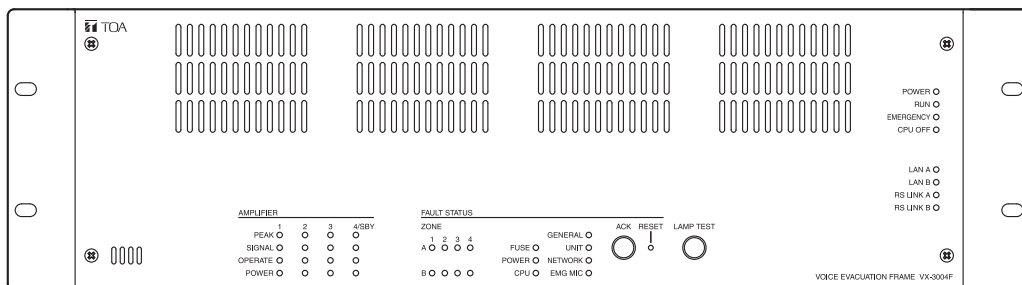

INTEGRATED VOICE EVACUATION SYSTEM VX-3000 SERIES

Thank you for purchasing TOA's Integrated Voice Evacuation System.
Please carefully follow the instructions in this manual to ensure long, trouble-free use of your equipment.



 1134
<p>TOA Electronics Europe GmbH Suederstrasse 282, 20537 Hamburg, Germany 1134-CPR-195 16 DOP 16-004</p>
<p>EN 54-16: 2008 Fire Detection and fire alarm systems - part 16: Voice alarm control and indication system for fire detection and fire alarm systems for buildings</p> <p>Options: Manual silencing of voice alarm condition manual reset of voice alarm condition voice alarm condition output indication of a fault related to voice alarm zones voice alarm manual control emergency microphones redundant power amplifiers</p>

When an EN 54-16 compliant VX-3000 system has to be installed, then carefully read the separate manual titled "APPENDIX: ADDITIONAL INSTALLATION INSTRUCTIONS FOR AN EN 54-16 COMPLIANT SYSTEM" and follow up the installation and configuration requirements explained therein. This APPENDIX contains the basic description of settings and installations, so please refer to the general instruction sections in this document for more details.

TABLE OF CONTENTS

Chapter 1 : NOTE

1. SAFETY PRECAUTIONS	1-2
2. GENERAL DESCRIPTION	1-6
3. SYSTEM FEATURES	1-6
4. SYSTEM EXAMPLE	1-6

Chapter 2 : NOMENCLATURE AND FUNCTIONS

1. VX-3004F/3008F/VX-3016F VOICE EVACUATION FRAME	2-2
2. VX-015DA/030DA/050DA DIGITAL POWER AMPLIFIER MODULE	2-9
3. VX-300LO LINE OUTPUT MODULE	2-11
4. VX-3000PM PREAMP MATRIX PANEL	2-12
5. VX-3000CT CONTROL PANEL	2-16
6. RM-200SF FIREMAN'S MICROPHONE	2-18
7. RM-320F FIREMAN'S MICROPHONE EXTENSION	2-21
8. RM-300X REMOTE MICROPHONE	2-22
9. RM-210F REMOTE MICROPHONE EXTENSION	2-25
10. RM-200RJ TERMINAL UNIT	2-26
11. RM-500 REMOTE MICROPHONE	2-27
12. SX-200EL END OF LINE UNIT	2-30
13. VM-300SV END OF LINE UNIT	2-30

Chapter 3 : INSTALLATION AND SETTING PROCEDURES (HARDWARE)

1. VX-015DA, VX-030DA, AND VX-050DA DIGITAL POWER AMPLIFIER MODULE	3-2
1.1. Changing the Speaker Line Voltage	3-2
1.2. Replacing the Blade Fuse	3-2

2. VX-3004F, VX-3008F, AND VX-3016F VOICE EVACUATION FRAME	3-3
2.1. Installing VX-015DA/030DA/050DA Digital Power Amplifier Module	3-3
2.2. The Zones Allocation Setting	3-5
3. VX-300LO LINE OUTPUT MODULE	3-7
3.1. The ID Number Setting	3-9
3.2. Setting the IP Address	3-10
4. VX-3000PM PREAMP MATRIX PANEL	3-11
4.1. Setting the IP Address	3-11
5. VX-3000CT CONTROL PANEL	3-14
5.1. Setting the IP Address	3-14
6. RM-200SF, RM-300X, AND RM-500 MICROPHONES	3-19
6.1. The ID Number Settings (RM-200F and RM-300X: Switches 1 – 3 operation or RM-500: Switches 2 – 4 operation)	3-19
6.2. Adjusting Microphone Sensitivity	3-22
6.3. Setting The RM-500's Menu	3-24
6.4. CPU Off Function (All-Zone Emergency Broadcast) Settings (RM-200SF: Switch 6 operation or RM-300X: Switch 5 operation)	3-30
6.5. Termination Setting (RM-200SF, RM-500: Switch 8 operation)	3-31
6.6. Using an External Microphone (RM-300X Only)	3-32
6.7. Setting the Level of the AUX Input Terminal (RM-500 Only)	3-33
6.8. Setting for using the direct selection mode (RM-500 Only)	3-33
6.9. Using an Auxiliary Input (RM-300X Only)	3-34
6.10. Compressor Function Setting (RM-200SF and RM-300X only)	3-36
6.11. Microphone Fault Detection Function Setting (RM-300X Only)	3-38
6.12. Installing the RM-200SF on a Wall	3-39
6.13. Installing the RM-320F on a Wall (RM-200SF only)	3-43
6.14. RM-300X Extension with the Addition of the RM-210F (Installed on a Flat Surface)	3-45
6.15. Installing the RM-300X on a Wall	3-46
6.16. Installing the RM-210F on a Wall (RM-300X Only)	3-47
6.17. Installing the RM-500 on a Wall	3-49
6.18. Creating Remote Microphone Name Labels (RM-200SF, RM-320F, RM-300X, and RM-210F only)	3-52
7. RACK MOUNTING	3-55
7.1. Affixing Declaration of Compliance (EN 54-16 Standard)	3-56
8. CONNECTIONS	3-57
8.1. Removable Terminal Plug Connection	3-57
8.2. Connecting the Cable to the Push-in Terminal Block	3-58
8.3. Input Equipment Connections	3-59
8.4. Speaker Connection	3-77
8.5. Control Output Terminal Connections	3-80
8.6. Control Input Terminal Connections	3-81
8.7. Emergency Control Input Terminal Connections	3-82
8.8. VX-3000 Unit's LAN Link Connector Connection	3-83
8.9. Sharing Standby Amplifier	3-89

8.10. Speaker Selector Extension	3-90
8.11. Analog Link Terminal Connections	3-91
8.12. Preamp Matrix Panel Connection	3-92
8.13. Control Panel Connections	3-95
9. SPEAKER LINE INITIAL SETTING	3-96
9.1. Setting Items	3-96
9.2. OPEN/SHORT Criterion by Comparing the Current Value with the Initial Value	3-96
9.3. Setting Procedures	3-97

Chapter 4 : APPENDIX

1. THE FIRMWARE VERSION CONFIRMATION	4-2
2. SPECIFICATIONS	4-4
2.1. VX-3004F Voice Evacuation Frame 4AB	4-4
2.2. VX-3008F Voice Evacuation Frame 8SS	4-7
2.3. VX-3016F Voice Evacuation Frame 16SS	4-10
2.4. VX-015DA Digital Power Amplifier Module 150 W	4-13
2.5. VX-030DA Digital Power Amplifier Module 300 W	4-14
2.6. VX-050DA Digital Power Amplifier Module 500 W	4-15
2.7. VX-300LO Line Output Module	4-16
2.8. VX-3000PM Preamp Matrix Panel	4-17
2.9. VX-3000CT Control Panel	4-18
2.10. RM-200SF Fireman's Microphone	4-19
2.11. RM-320F Fireman's Microphone Extension	4-20
2.12. RM-300X Remote Microphone	4-21
2.13. RM-210F Remote Microphone Extension	4-22
2.14. RM-200RJ Terminal Unit	4-22
2.15. RM-500 Remote Microphone	4-23
2.16. WB-RM500 Wall Mounting Bracket	4-24
2.17. VM-300SV End Of Line Unit	4-24

Chapter 1

NOTE

1. SAFETY PRECAUTIONS

- Before installation or use, be sure to carefully read all the instructions in this section for correct and safe operation.
- Be sure to follow all the precautionary instructions in this section, which contain important warnings and/or cautions regarding safety.
- After reading, keep this manual handy for future reference.
- This equipment is not suitable for use in locations where children are likely to be present.
- An equipment installer and the person in charge of maintenance are required to fully understand the functions and structure of this unit, then be aware of electrical and mechanical risks before work.
Before starting work, he or she should take possible measures to prevent occurrence of such risks.
Be sure to contact your nearest TOA dealer if you need to confirm unclear points about risk sources of this unit.

Safety Symbol and Message Conventions

Safety symbols and messages described below are used in this manual to prevent bodily injury and property damage which could result from mishandling. Before operating your product, read this manual first and understand the safety symbols and messages so you are thoroughly aware of the potential safety hazards.



WARNING

Indicates a potentially hazardous situation which, if mishandled, could result in death or serious personal injury.

When Installing the Unit

- (Except VX-300LO)
Do not expose the unit to rain or an environment where it may be splashed by water or other liquids, as doing so may result in fire or electric shock.
- (Applicable to VX-3004F, VX-3008F, VX-3016F, VX-015DA, VX-030DA, VX-050DA, VX-3000PM, VX-3000CT, RM-200SF, RM-300X, RM-500, VX-3000DS, and VX-3150DS only)
Use the unit only with the voltage specified on the unit. Using a voltage higher than that which is specified may result in fire or electric shock.
- (Applicable to VX-3000DS and VX-3150DS only)
Do not cut, kink, otherwise damage nor modify the power supply cord. In addition, avoid using the power cord in close proximity to heaters, and never place heavy objects -- including the unit itself -- on the power cord, as doing so may result in fire or electric shock.
- (Applicable to RM-200SF, RM-300X, RM-500, RM-320F, and RM-210F only)
Avoid installing or mounting the unit in unstable locations, such as on a rickety table or a slanted surface. Doing so may result in the unit falling down and causing personal injury and/or property damage.
- (Applicable to RM-200SF, RM-300X, RM-500, RM-320F, and RM-210F only)
Install the unit only in a location that can structurally support the weight of the unit and the mounting bracket. Doing otherwise may result in the unit falling down and causing personal injury and/or property damage.
- Since the unit is designed for indoor use, do not install it outdoors. If installed outdoors, the aging of parts causes the unit to fall off, resulting in personal injury. Also, when it gets wet with rain, there is a danger of electric shock.

When the Unit is in Use

- Should the following irregularity be found during use, immediately switch off the power, disconnect the power supply plug from the AC outlet and contact your nearest TOA dealer. Make no further attempt to operate the unit in this condition as this may cause fire or electric shock.
 - If you detect smoke or a strange smell coming from the unit
 - If water or any metallic object gets into the unit
 - If the unit falls, or the unit case breaks

- (Applicable to VX-3000DS and VX-3150DS only)
If the power supply cord is damaged (exposure of the core, disconnection, etc.)
- If it is malfunctioning (no tone sounds)
- To prevent a fire or electric shock, never open nor remove the unit case as there are high voltage components inside the unit.
Refer all servicing to qualified service personnel.
- Do not place cups, bowls, or other containers of liquid or metallic objects on top of the unit. If they accidentally spill into the unit, this may cause a fire or electric shock.
- (Applicable to VX-3004F, VX-3008F, VX-3016F, VX-015DA, VX-030DA, VX-050DA, VX-3000DS, and VX-3150DS only)
Do not insert nor drop metallic objects or flammable materials in the ventilation slots of the unit's cover, as this may result in fire or electric shock.
- (Applicable to VX-3000DS and VX-3150DS only)
Do not touch a power supply plug during thunder and lightning, as this may result in electric shock.
- When replacing the fuse, be sure to use the supplied one. Using any other fuse than supplied may cause fire or electric shock.

VX-015DA:	Blade 10 A
VX-030DA:	Blade 20 A
VX-050DA:	Blade 30 A
VX-3000DS and VX-3150DS:	AC T8A H, AC T6.3A L, and Blade 35 A
- Be sure to switch off the amplifier's power when replacing the fuse.
Inserting or removing the fuse with the amplifier's power on may cause personal injury.
- (Applicable to VX-3000DS and VX-3150DS only)
Handle or use the batteries properly.
Doing otherwise may cause leakage or explosion of the batteries, resulting in a fire, personal injury, damage to peripheral equipment, or contamination of environment.



CAUTION

Indicates a potentially hazardous situation which, if mishandled, could result in moderate or minor personal injury, and/or property damage.

When Installing the Unit

- (Applicable to VX-3000DS and VX-3150DS only)
Never plug in nor remove the power supply plug with wet hands, as doing so may cause electric shock.
- (Applicable to VX-3000DS and VX-3150DS only)
When unplugging the power supply cord, be sure to grasp the power supply plug; never pull on the cord itself.
Operating the unit with a damaged power supply cord may cause a fire or electric shock.
- (Applicable to VX-3004F, VX-3008F, VX-3016F, VX-015DA, VX-030DA, VX-050DA, VX-3000DS, and VX-3150DS only)
Do not block the ventilation slots in the unit's cover. Doing so may cause heat to build up inside the unit and result in fire.
(Applicable to VX-015DA, VX-030DA, and VX-050DA only)
Also, periodically clean the ventilation slots of dust.
- Avoid installing the unit in humid or dusty locations, in locations exposed to the direct sunlight, near the heaters, or in locations generating sooty smoke or steam as doing otherwise may result in fire or electric shock.

- (Applicable to VX-3004F, VX-3008F, VX-3016F, VX-015DA, VX-030DA, VX-050DA, VX-3000PM, VX-3000CT, RM-200SF, RM-300X, VX-3000DS, and VX-3150DS only)
Note correct polarity (positive and negative orientation) when connecting the power supply cord. Reversed polarity connections will cause damage to the unit.
- (Applicable to VX-015DA, VX-030DA, and VX-050DA only)
To avoid electric shocks, be sure to switch off the VX-3000F's power when connecting the unit.
- (Applicable to VX-3004F, VX-3008F, VX-3016F, VX-3000PM, VX-3000CT, VX-3000DS, and VX-3150DS only)
System units (except remote microphones) are designed exclusively to be mounted in an equipment rack. Be sure observe the following instructions when rack-mounting the unit. Failure to do so may cause a fire or personal injury.
 - Install the equipment rack on a stable, hard floor. Fix it with anchor bolts or take other arrangements to prevent it from falling down.
 - (Applicable to VX-3004F, VX-3008F, VX-3016F, VX-3000PM, and VX-3000CT only)
The supplied rack-mounting screws can be used for the TOA equipment rack only. Do not use them for other racks.
 - (Applicable to VX-3000DS and VX-3150DS only)
Rack-mounting screws are not supplied with the unit. Prepare them that are appropriate for the equipment rack.
 - (Applicable to VX-3000DS and VX-3150DS only)
When connecting the unit's power cord to an AC outlet, use the AC outlet with current capacity allowable to the unit.
- (Applicable to VX-3000DS and VX-3150DS only)
When connecting multiple appliances to a single power socket through a multi-outlet power strip, a total current consumption of the appliances must not exceed the allowable current capacity of the power socket. Failure to observe this instruction may result in a fire or electric shock.
- (Applicable to VX-3000DS and VX-3150DS only)
When 2 or more AC power cords are connected to a multi-outlet power strip, never remove the power strip from a power source.

When the Unit is in Use

- (Applicable to VX-3004F, VX-3008F, VX-3016F, VX-015DA, VX-030DA, VX-050DA, and VX-3000PM only)
Do not operate the unit for an extended period of time with the sound distorting. Doing so may cause the connected speakers to heat, resulting in a fire.
- (Applicable to RM-200SF, RM-300X, and RM-500 only)
Use the specified AC adapter for the unit. Note that the use of other adapter may cause a fire.
- (Applicable to VX-015DA, VX-030DA, and VX-050DA only)
Contact your TOA dealer as to the cleaning. If dust is allowed to accumulate in the unit over a long period of time, a fire or damage to the unit may result.
- (Applicable to VX-3000DS and VX-3150DS only)
Make sure to observe the following handling precautions so that a fire or personal injury does not result from leakage or explosion of the battery.
 - Do not short, disassemble, heat nor put the battery into a fire.
 - Avoid using both new and old batteries together.
 - Never charge batteries of the type which are not rechargeable.
 - Do not solder a battery directly.
 - Be sure to use the specified type of batteries.
 - Note correct polarity (positive and negative orientation) when connecting a battery to the unit.
 - Avoid locations exposed to the direct sunlight, high temperature and high humidity when storing batteries.
- (Applicable to RM-200SF, RM-300X, RM-500, RM-320F, and RM-210F only)
Have the unit checked periodically by the shop from where it was purchased. Failure to do so may result in corrosion or damage to the unit or its mounting bracket that could cause the unit to fall, possibly causing personal injury.

Warning: This equipment is compliant with Class A of CISPR 32. In a residential environment this equipment may cause radio interference.

2. GENERAL DESCRIPTION

The TOA VX-3000 Series Integrated Voice Evacuation System is designed for both general and emergency purpose broadcasts.

It is comprised of the Voice Evacuation Frame, Digital Power Amplifier modules, Line Output module, Preamp Matrix Panel, Control Panel, Power Supply unit, Emergency Power Supply, and a user-specified number of Remote Microphones.

The system complies with the EN54-16 Standard and its failure detection circuitry operates continuously to check components and speaker lines for any irregularities. If detected, failure warnings are provided by way of an LED indicator and a buzzer.

The VX-3000 system allows 4 types of broadcasts to be made: General-purpose broadcast such as general paging and BGM, Emergency warning broadcast that can be broadcast with priority over the Emergency broadcast, Emergency broadcast that the emergency messages are to be broadcast by an automatic announcement device or remote microphone, All-zone emergency broadcast* that is to be made available even during system malfunctions or failures.

Two patterns of the Emergency broadcast can be activated simultaneously.

The dedicated software is used to perform all necessary settings related to the entire system operation and functions including system configurations, input-to-output signal routing, function assignment to the operation keys, operation of the control terminals, and selection of the failure detection points.

* Available when an analog link is connected.

3. SYSTEM FEATURES

- VX-3000 system is a voice evacuation system.
- Decentralized configuration is possible via network.
- VX-3000 system is constructed up to 160 AB zones or 640 zones as system.
- Speaker Selector function is implemented, then VX-3000 system is able to cover many zones.
- A general broadcast for a sound quality regulating function is possible to digitalize all sound.
- A general broadcasting is possible by latitude setting of control input/output and priorities.

4. SYSTEM EXAMPLE

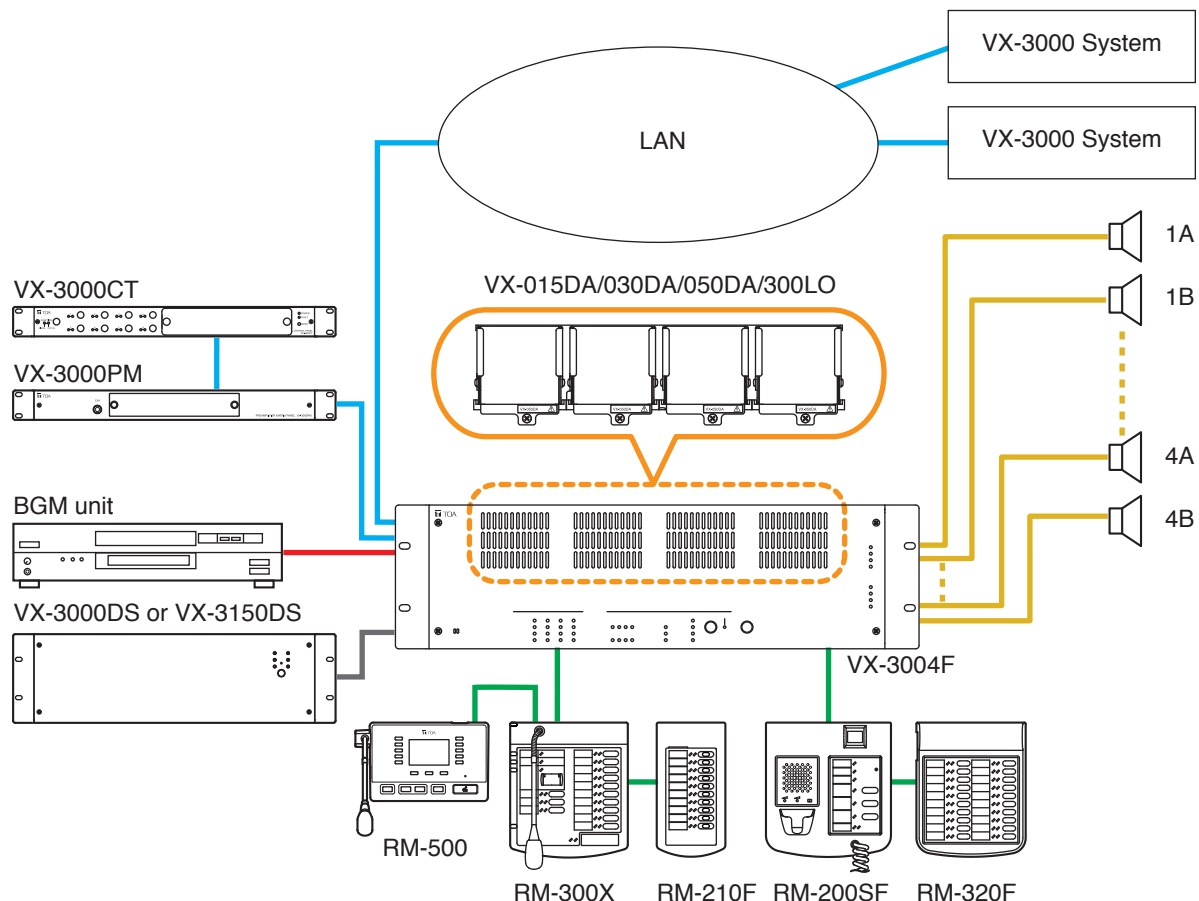

Chapter 2

NOMENCLATURE AND FUNCTIONS

1. VX-3004F/3008F/VX-3016F VOICE EVACUATION FRAME

VX-3004F, VX-3008F, and VX-3016F are collectively referred to as "VX-3000F" in this manual.

- The VX-3000F is a unit designed to control the Voice evacuation announcements of the VX-3000 series voice evacuation system.
- The VX-3000F is equipped with the audio input terminals and has the module slots for optionally accommodating 3 kinds of digital power amplifier modules and a line output module.
- Compatible with network, the system can be configured in distributed arrangement.

[Front]

VX-3004F

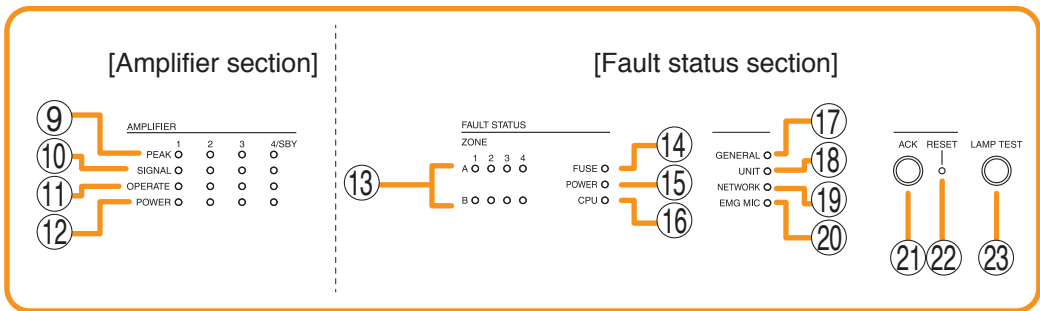
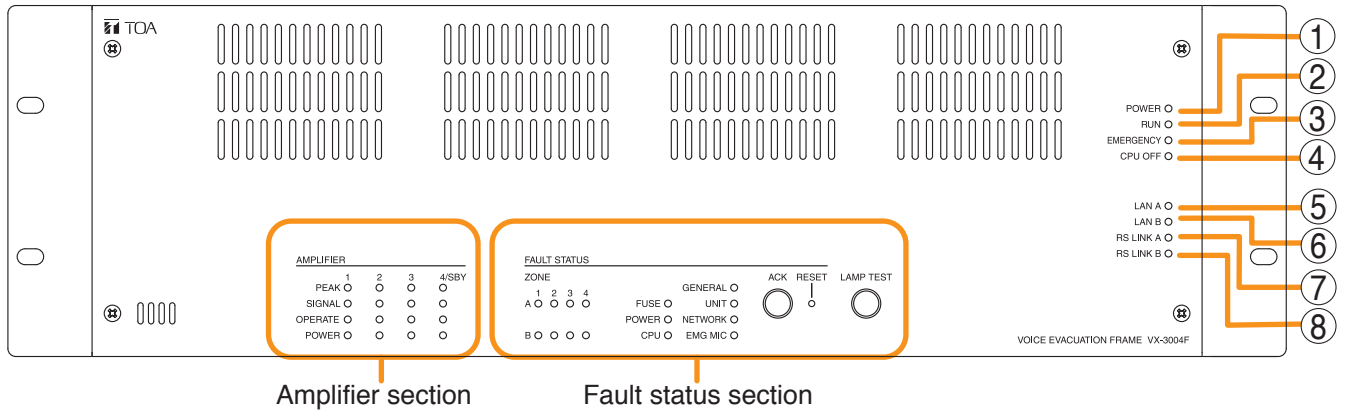

VX-3008F

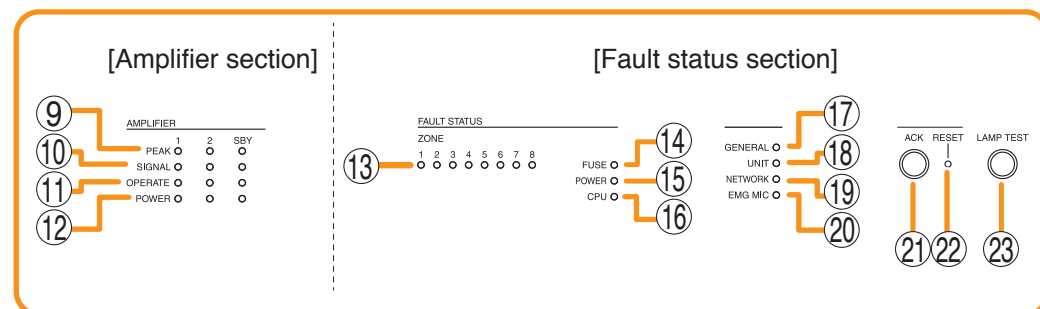
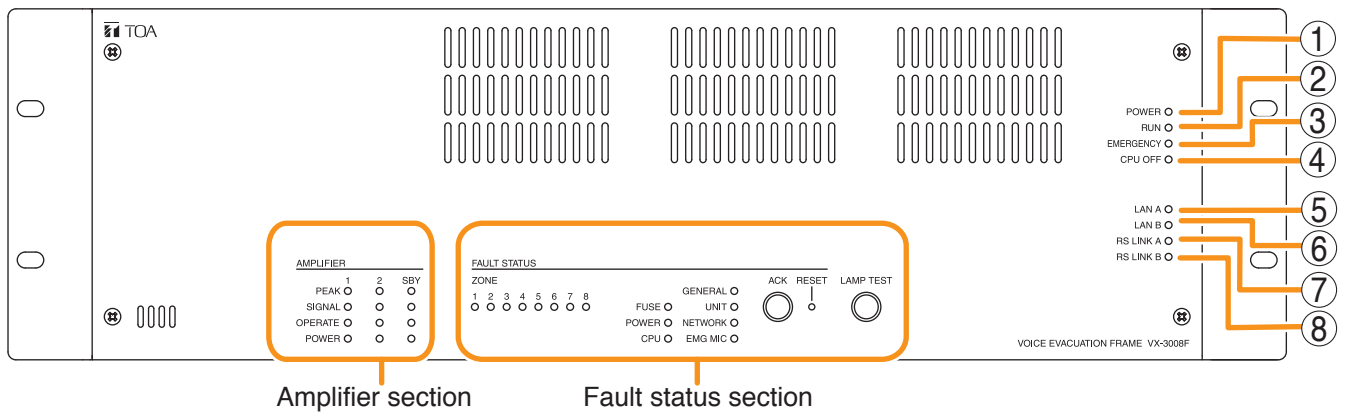

VX-3016F

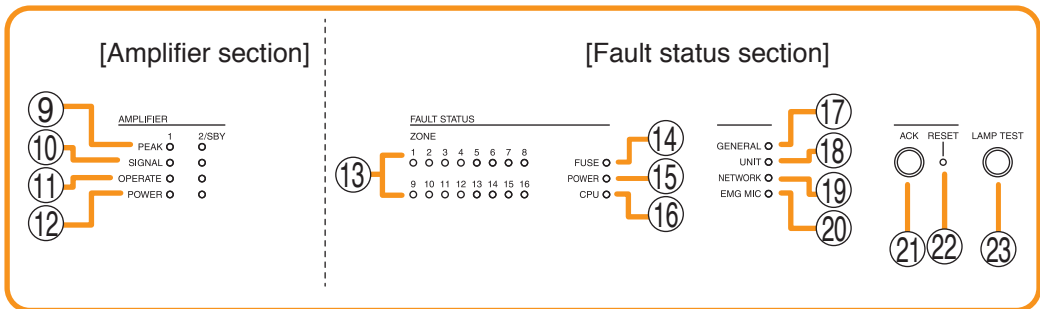
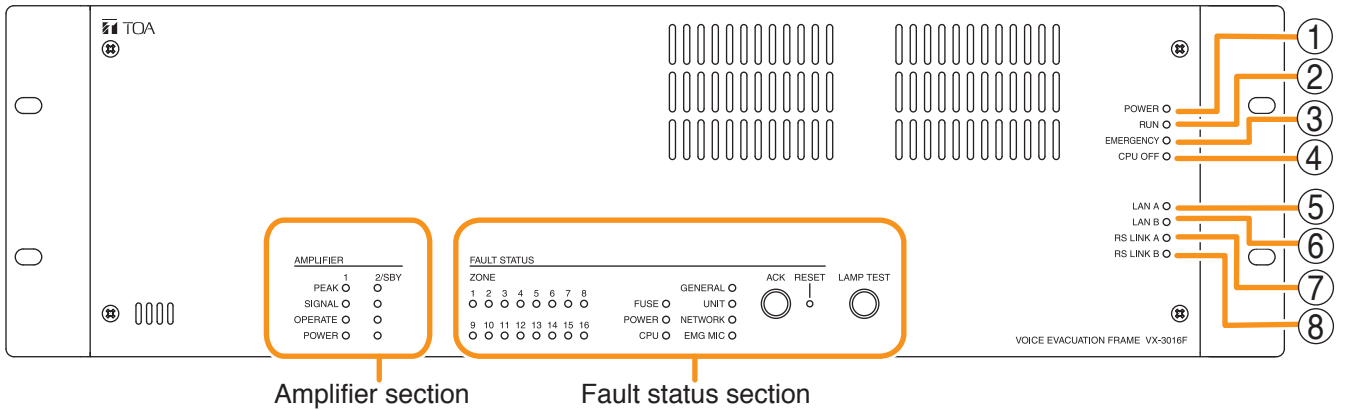

1. Power indicator (Green)

Lights when the power is supplied.
Flashes in standby state.

2. RUN indicator (Green)

Normally flashes continuously. Goes off while in a CPU off state (p. 3-30). Also goes off while in standby state*1.

*1 A state during power failures or a state that the unit is internally initialized after power-on

3. Emergency indicator (Red)

Lights when the VX-3000 system is in an emergency condition or while in a CPU off state (p. 3-30).

4. CPU off indicator (Red)

Lights while in a CPU off state (p. 3-30).

5. LAN A indicator (Green)

Lights when the LAN link A connector (49) on the rear panel is connected, and flashes during LAN communications.

6. LAN B indicator (Green)

Lights when the LAN link B connector (49) on the rear panel is connected, and flashes during LAN communications.

7. RS link A indicator (Green)

Lights when the RS link A connector (50) on the rear panel is connected, and flashes while communications are being performed via the RS link A connector.

8. RS link B indicator (Green)

Lights when the RS link B connector (50) on the rear panel is connected, and flashes while communications are being performed via the RS link B connector.

9. Amplifier peak indicators (Red)

Show the input signal state to the power amplifier when the module is installed.

The indicator corresponding to the module slot port will light if the input signal level exceeds +0.5 dB*2.

It remains unlit when no module is installed.

10. Amplifier signal indicators (Green)

Show the input signal state to the power amplifier when the module is installed.

The indicator corresponding to the module slot port will light if the input signal level exceeds -25 dB*2.

It remains unlit when no module is installed.

*2 0 dB = 1 V

11. Amplifier operate indicators (Green)

The indicator corresponding to the module slot port will light or go off depending on the operation state of the power amplifier when the power amplifier module is installed.

Operating status	Indicator status
In-use	Lit
Standby	Unlit
DC fuse blowout	Unlit
Protection* activated	Unlit

* The built-in protection circuit operates if some irregularities occur inside the amplifier such as abnormal temperature rise or fan failure.

It remains unlit when the line output module is installed.

It remains unlit when no module is installed.

12. Amplifier power indicators (Green)

The indicator corresponding to the module slot port will light or go off depending on the operation state of the power amplifier when the power amplifier module is installed.

Operating status	Indicator status
In-use	Lit
Standby	Lit
DC fuse blowout	Unlit
Protection* activated	Lit

* The built-in protection circuit operates if some irregularities occur inside the amplifier such as abnormal temperature rise or fan failure.

It remains unlit when the line output module is installed.

It remains unlit when no module is installed.

13. Zone fault indicators (Yellow)

Lights or flashes when the speaker line surveillance function detects 3 types of failures: poor insulation (ground fault), overload (line short), and cable disconnection.

14. Fuse fault indicator (Yellow)

Lights or flashes when DC fuse blowout are detected.

15. Power fault indicator (Yellow)

Lights or flashes when failures are detected in Power Supply Manager.

16. CPU fault indicator (Yellow)

Lights while in a CPU off state (p. 3-30) or when a failure is detected in the VX-3000F.

17. General fault indicator (Yellow)

Lights while in a CPU off state (p. 3-30) Lights or flashes when a failure is detected in the system.

18. Unit fault indicator (Yellow)

Lights or flashes when a failure is detected in the unit.

19. Network fault indicator (Yellow)

Lights or flashes when failures are detected in communications with the other VX-3000F. It also flashes or lights at network setting and when a configuration error occurs.

20. Emergency microphone fault indicator (Yellow)

Lights or flashes when failures are detected in Emergency Microphone.

21. Fault ACK key

The buzzer will sound and Fault indicator will flashes when a failure is detected in the system. Press this key to stop the buzzer and switches the Fault indicator from flashing to steady on.

22. Fault reset key

Pressing this key resets the failure information (the buzzer and fault indicators) for the system.

23. Lamp test key

Used to test each indicator on the front panel of the VX-3000F Voice Evacuation Frame. All indicators remain lit and the buzzer sounds as long as this key is pressed.

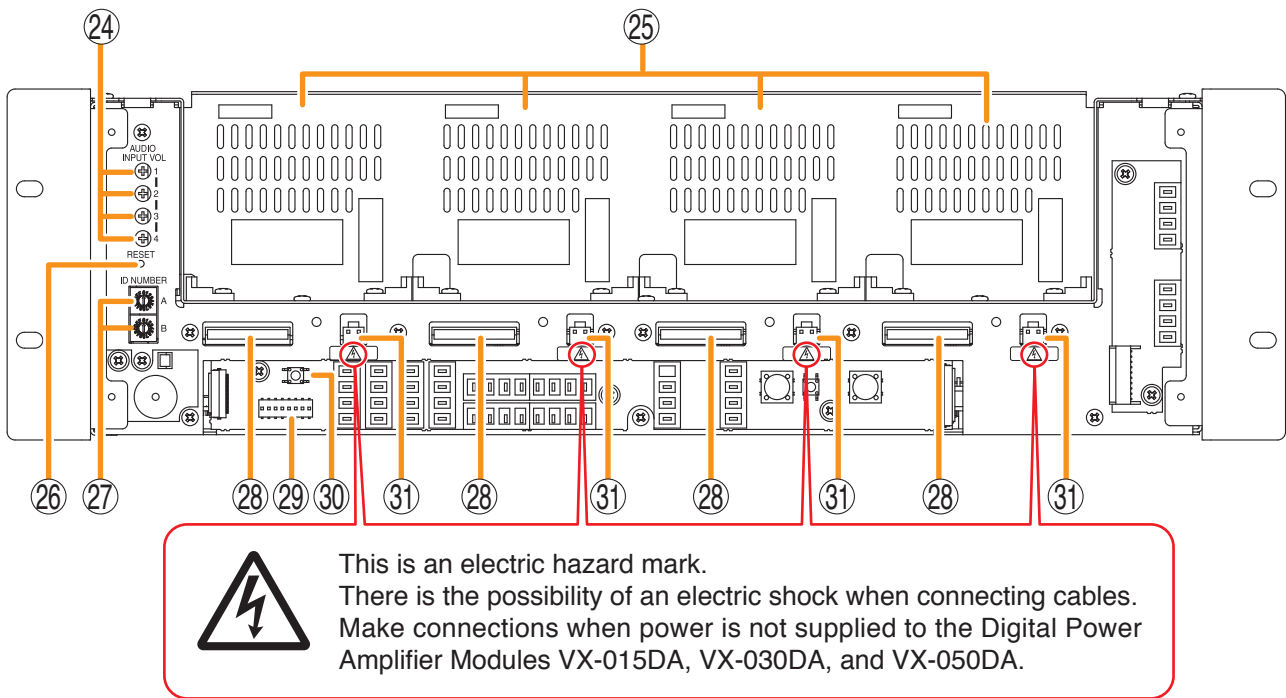
[Front panel detached]**24. Audio input volume controls**

Adjust the input volume of each input channel. Rotating the control fully counterclockwise mutes the input sound source connected to that channel.

25. Module slots

Accommodate the VX-015DA, VX-030DA, or VX-050DA, Digital Power Amplifier Module and VX-300LO Line Output Module. The maximum number of the connectable units is as follows.

VX-3004F: 4 units

VX-3008F: 3 units for the digital power amplifier module, and 2 units for the line output module

VX-3016F: 2 units

26. Reset key

Pressing this key reactivates the VX-3000F.

27. ID switch

Sets the VX-3000F's ID number (device number).

28. DA control link connector

Connect this connector to the DA control link connector of the installed digital power amplifier module or the line output module.

29. DIP switch**[VX-3004F]**• **Switches 1 – 6**

These switches are not used.

• **Switch 7**

Used when confirming the firmware version. (See p. 4-2.)

• **Switch 8**

Used to set the IP address. (See p. 3-10.)

[VX-3008F]• **Switches 1 – 3**

Used to allocate speaker lines. (See p. 3-5.)

• **Switches 4 – 6**

These switches are not used.

• **Switch 7**

Used when confirming the firmware version. (See p. 4-2.)

• **Switch 8**

Used to set the IP address. (See p. 3-10.)

[VX-3016F]• **Switch 1**

Used to place the unit in 2 channel mode operation. (See p. 3-5.)

• **Switches 2 – 6**

These switches are not used.

• **Switch 7**

Used when confirming the firmware version. (See p. 4-2.)

• **Switch 8**

Used to set the IP address. (See p. 3-10.)

Note

By default, switches 1 – 7 are set to OFF, and switch 8 to ON.

30. Impedance initialize key

Press this key to acquire the initial value of the speaker line impedance as failure detection is executed on the basis of the impedance change.

31. DA output link connector

Connect this connector to the DA output link connector of the installed digital power amplifier module.

[Rear]

VX-3004F

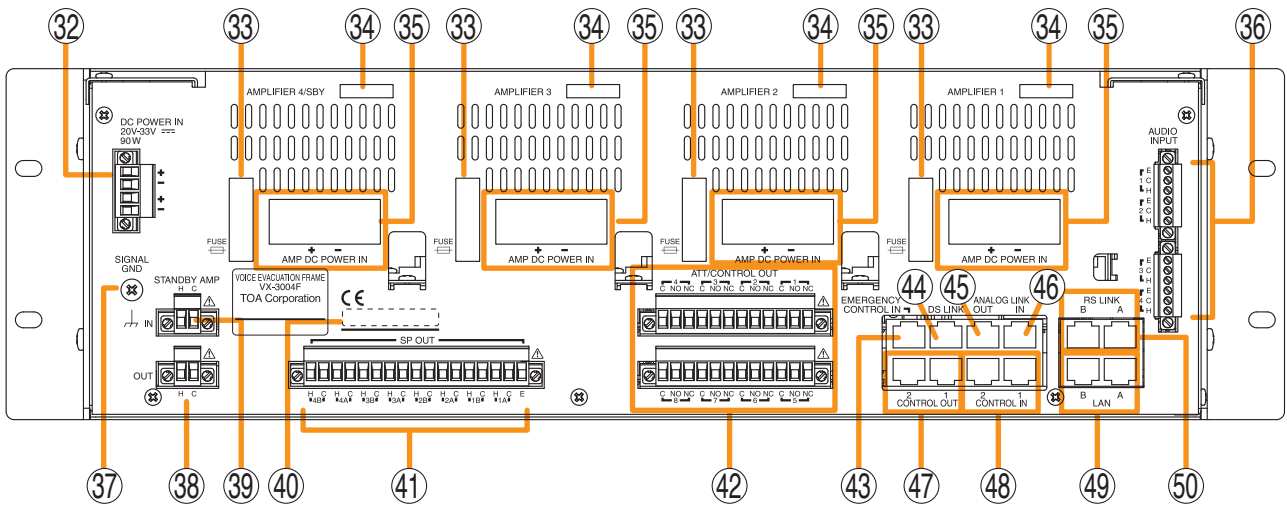

VX-3008F

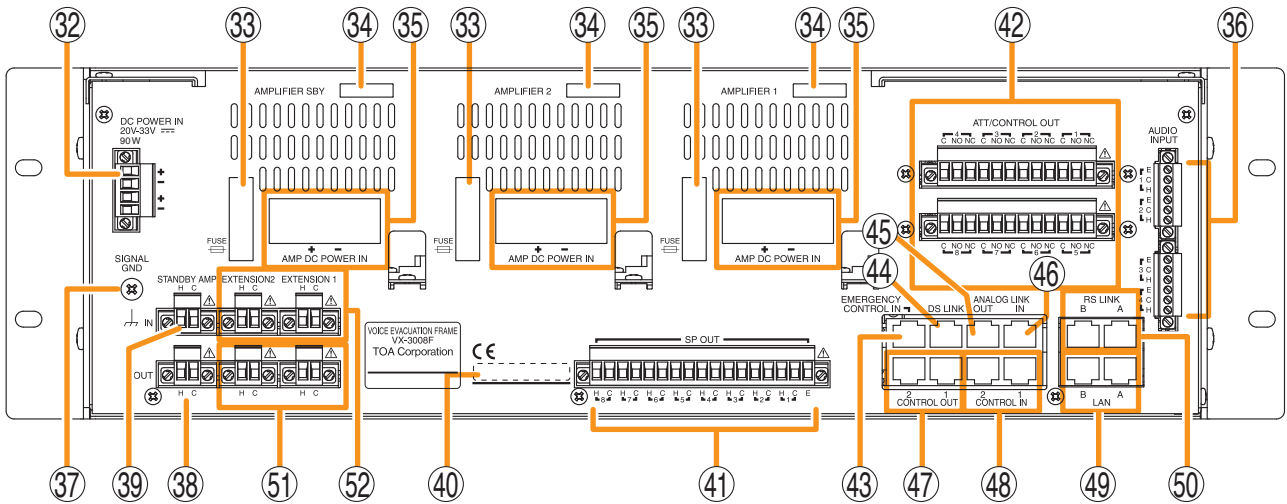

VX-3016F

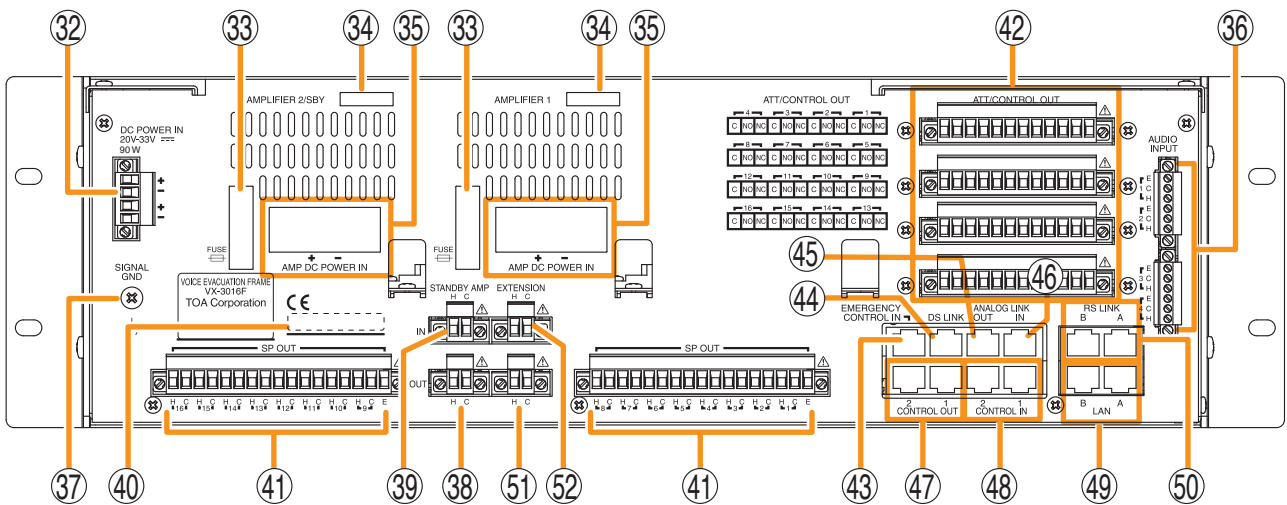

32. DC power input terminal

Connect an optional DC power supply unit to this terminal. Select the DC power supply source with consideration given to the current power consumption of the system the VX-3000F is to be connected to.

(See the Instruction Manual attached to the VX-3000DS or the VX-3150DS.)

33. Fuse

When an amplifier module is installed, its fuse can be checked.

You can replace the fuse with the amplifier module installed to the VX-3000F. (See p. 2-10.)

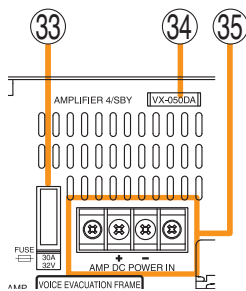

34. Amplifier model number indication window

When a power amplifier module is installed, you can check its model number.

35. Amplifier DC power input terminal

When a power amplifier module is installed, you can check its power input terminals. (See p. 2-10.)

36. Audio input terminals

Electronically-balanced 47 kΩ, -20 dB*/-60 dB*, Terminal connectors. LINE or MIC input can be selected, and the phantom power supply turned on and off. (See the separate Setting Software Instructions, "UNIT CONFIGURATION SETTINGS.")

* 0 dB = 1 V

37. Signal ground terminal

Hum noise may be generated when external equipment is connected to the unit. Connecting this terminal to the signal ground terminal of the external equipment may reduce the hum noise.

Note: This terminal is not for protective ground.

38. Standby amplifier output connector

When a standby amplifier is shared by multiple VX-3000F units, connect this connector to the standby amplifier input connector of other VX-3000F.

39. Standby amplifier input connector

When making the VX-3000F with no standby amplifier share the standby amplifier installed to other VX-3000F, connect this connector to other VX-3000F's standby amplifier output connector.

40. MAC address

This is the MAC address* for the unit. Since the relationship of each unit location to its MAC address is established when setting the network attributes, keep track of this relationship for later use.

* The unit's MAC address consists of 12 hyphenated alphanumeric characters.

41. Speaker output terminals

Connect speakers to these outputs.

42. ATT/Control output terminals

These terminals permit the VX-3000 system to control other connected external equipment.

Alternatively, these terminals become attenuator control outputs by setting.

43. Emergency control input terminal

Connect to an automatic fire alarm system and activate emergency broadcasts, play back/stop automatic emergency announcements and reset emergency broadcasts.

Two isolated voltage inputs which activates when the polarity of the applied voltage (24 V DC is kept applied to this terminal under normal condition) is reversed.

44. DS link connectors

Connects this connector to the DS LINK IN connector of the VX-3000DS or the VX-3150DS.

45. Analog link output connector

Connect this connector to the analog link input connector of the other VX-3000F.

46. Analog link input connector

Connect this connector to the analog link output connector of the other VX-3000F.

47. Control output connectors

These RJ45 connectors permit the VX-3000 system to control other connected external equipment.

48. Control input connectors

These RJ45 connectors receive activation signals from external equipment to enable external VX-3000 system control.

Alternatively, these connectors become EOL inputs by setting.

49. LAN link connectors

Connect the VX-3000 system components or switching hubs. (See [p. 3-83 "VX-3000 Unit's LAN Link Connector Connection."](#))

50. RS link connectors

Connect the RM-200SF Fireman's Microphone or RM-300X/500 Remote Microphone to these connectors.

Note

Only one RM-200SF can be connected to each connector if the system is required to comply with EN54-16.

51. Extension output connectors

Connect these connectors to the Extension input connector of the VX-3000F in SS mode (with no built-in Digital Power Amplifier) for zone number expansion by the VX-3008F or VX-3016F.

52. Extension input connectors

Connect these connectors of the VX-3008F or VX-3016F set to SS mode to the Extension output connector of the VX-3000F in normal mode.

2. VX-015DA/030DA/050DA DIGITAL POWER AMPLIFIER MODULE

- The VX-015DA, VX-030DA, and VX-050DA are Digital power amplifier modules used for the VX-3000 system.
- They are module types with 1 channel of class-D digital power amplifier, which contributes to energy-saving and light weight design.
- The VX-015DA, VX-030DA, and VX-050DA also feature standby mode to be set for reducing standby power consumption.
- They require VX-3000F control unit and VX-3000DS or VX-3150DS power supply unit.

Module lineup includes the following 3 models different in rated output.

VX-015DA :150 W

VX-030DA :300 W

VX-050DA :500 W

[Front]

Appearance with
a filter detached

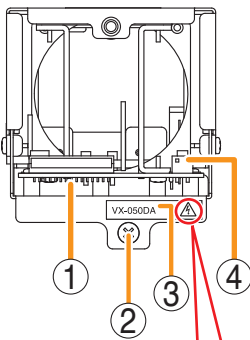

Appearance with
a filter attached

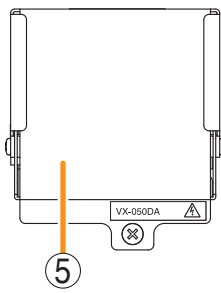

This is an electric hazard mark.
There is the possibility of an electric shock when connecting cables.
Make connections when power is not supplied to the Digital Power Amplifier Modules VX-015DA, VX-030DA, and VX-050DA.

1. DA control link connector

Connect this connector to the DA control link connector of the VX-3000F to which this module is installed using the supplied harness.

2. Fixing screw

Fixes the module to the VX-3000F.

3. Model number indication

4. DA output link connector

Connect this connector to the DA output link connector of the VX-3000F to which this module is installed using the supplied harness.

5. Filter

Dustproof filter.

Remove and clean the filter periodically.

If the filter becomes clogged, heat will be trapped inside the module.

[Rear]

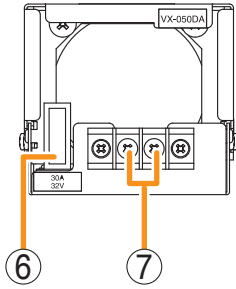

6. Fuse

Use a blade fuse described below depending on the power amplifier's rated output.

VX-015DA : 10 A

VX-030DA : 20 A

VX-050DA : 30 A

7. DC power input terminal

Connect an optional DC power supply unit to this terminal. (See the Instruction Manual attached to the VX-3000DS or the VX-3150DS.)

[Left Side]

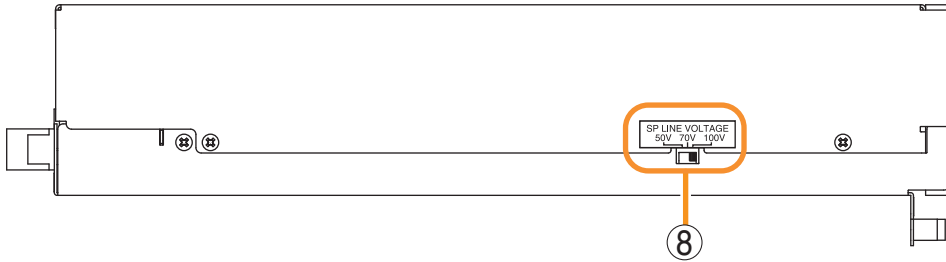

8. Output voltage selection switch

Used to select power amplifier's rated output voltage.

3. VX-300LO LINE OUTPUT MODULE

- The VX-300LO is a module that outputs the VX-3000F's audio signals at the line level.
- Designed to be installed in the VX-3000F, it outputs audio signals from the VX-3000F to an external device.

[Front]

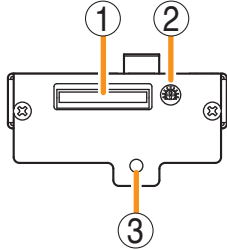

1. DA control link connector

Connect this connector to the DA control link connector of the VX-3000F to which this module is installed using the supplied harness.

2. Volume control

Fine adjusts the output level in the range of $-\infty$ to 0 dB depending on the input sensitivity of the connected device.

Rotate this control clockwise to increase the volume level and counterclockwise to decrease it. The output level is factory-preset to "0 dB."

3. Fixing screw hole

Secure the module to the VX-3000F with the supplied screw.

[Top]

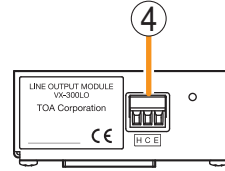

4. Audio output terminal

Removable terminal block (3P)
Outputs audio signals at the line level.

4. VX-3000PM PREAMP MATRIX PANEL

- The VX-3000PM is a 1U size*1 Preamplifier matrix panel mountable in an EIA standard equipment rack.
- The number of audio inputs, control inputs, and control outputs can be increased by connecting the VX-3000PM to the VX-3000F via network. A single VX-3000PM unit can be connected to a single VX-3000F unit.
- The VX-3000PM is equipped with 8 audio inputs, to which various types of audio sources can be connected.
- The VX-3000PM is equipped with 20 control inputs and 10 control outputs, which accept the broadcast activation signals from external sources and control external devices depending on the broadcast status.

*1 1U size = 44.5 mm (standard size)

[Front]

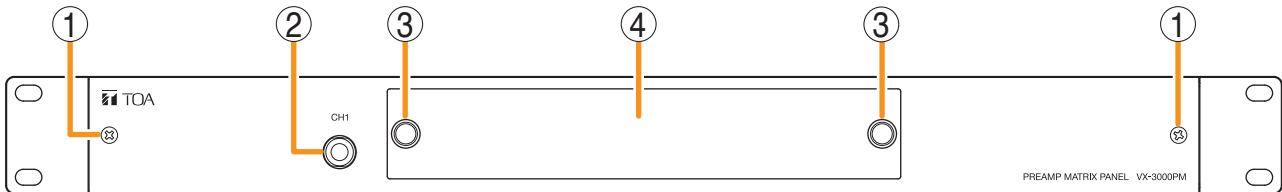

1. Fixing screws for front panel

2. Input 1 jack [CH1]

Insert the microphone's phone plug into this jack. This Input 1 takes precedence over the rear-mounted Audio input terminal 1 internally connected to the Input 1. Inserting the phone plug into this Input 1 jack disconnects the input of the rear-mounted Audio input terminal 1.

3. Volume control section cover knob

The cover over the volume control section can be removed by pulling the both knobs.

4. Volume control section cover

The volume controls for all input channels are located inside this cover.

[Front panel detached]

When the front panel is removed by loosening the front panel mounting screws, the input volume controls and the setting switches are exposed.

You can access the input volume controls when you remove the volume control section cover without detaching the front panel.

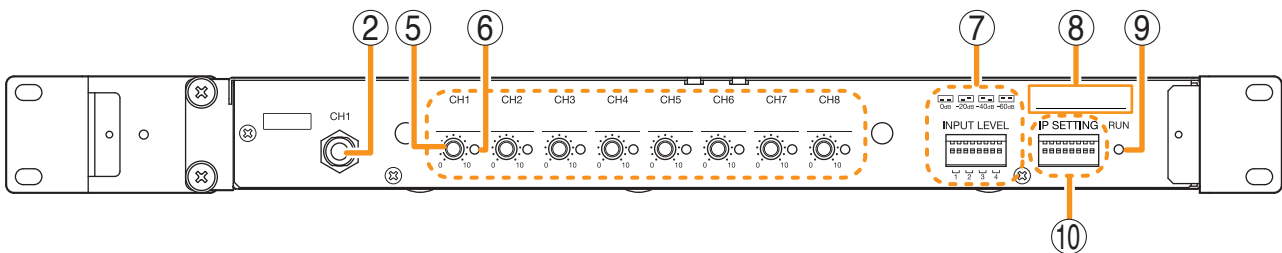

5. Volume control

Volume controls for each input. Inputs 1 to 8 volume controls are arranged in order from left to right. The volume increases as the knob is rotated clockwise, and is minimized when the knob is rotated fully counterclockwise (Position "0").

6. Signal indicator (Green)

Signal indicators for each input. Lights when the signal above a certain level is input. The table below shows the appropriate relationship between the input level setting and the lighting level.

Input level setting	Lighting level
0 dB*2	-25 dB*2
-20 dB*2	-45 dB*2
-40 dB*2	-65 dB*2
-60 dB*2	-85 dB*2

*2 0 dB = 1 V

7. Input level setting switch

Each input level of Inputs 1 through 4 are determined by ON/OFF combination of 2 switches. You can select one of the following 4 input levels depending on the input signal level: 0 dB*2 or -20 dB*2 (line level), and -40 dB*2 or -60 dB*2 (microphone level). (Factory default setting: 0 dB*2) The table below shows the relationship between the switch ON/OFF combination and the input level.

Switch ON/OFF combination	Input level
OFF OFF	0 dB*2
OFF ON	-20 dB*2
ON OFF	-40 dB*2
ON ON	-60 dB*2

*2 0 dB = 1 V

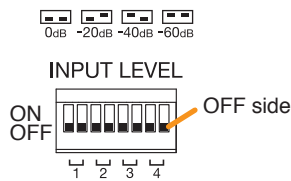

Note: Switches 1 through 8 numbered from left to right.

(Factory default setting: All set to OFF)

• **Switches 1, 2**

Used to set the input level of Audio input 1.

• **Switches 3, 4**

Used to set the input level of Audio input 2.

• **Switches 5, 6**

Used to set the input level of Audio input 3.

• **Switches 7, 8**

Used to set the input level of Audio input 4.

Note

Do not touch the input level setting switch during broadcast.

8. MAC address

This is the MAC address* for the unit. Since the relationship of each unit location to its MAC address is established when setting the network attributes, keep track of this relationship for later use.

* The unit's MAC address consists of 12 hyphenated alphanumeric characters.

9. RUN indicator

Continuously flashes when the unit's CPU is operating normally.

10. IP address setting switch

Sets the unit's IP address.

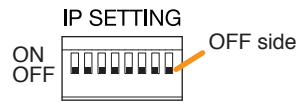

Note: Switches 1 through 8 numbered from left to right.

(Factory default setting: All set to OFF)

• **Switch 1**

Sets whether to enable or disable IP address setting by the IP address setting switch.

ON: Enables the IP address set by the IP address setting switch.

OFF: Disables the IP address set by the IP address setting switch and enables the one set using the VX-3000 Setting Software.

• **Switches 2 – 8**

Set the IP address by ON/OFF combination of 7 switches. (See p. 3-11.)

Notes

- If you have reset the IP address after power-on, be sure to restart the unit.
- The IP address setting switch allows the IP address to be set only in the range of "192.168.14.51" to "192.168.14.100". If you wish to set IP address out of this range, set it using the VX-3000 Setting Software. (See the separate Setting Software Instructions, "UNIT DETECTION AND NETWORK SETTINGS.")

[Rear]

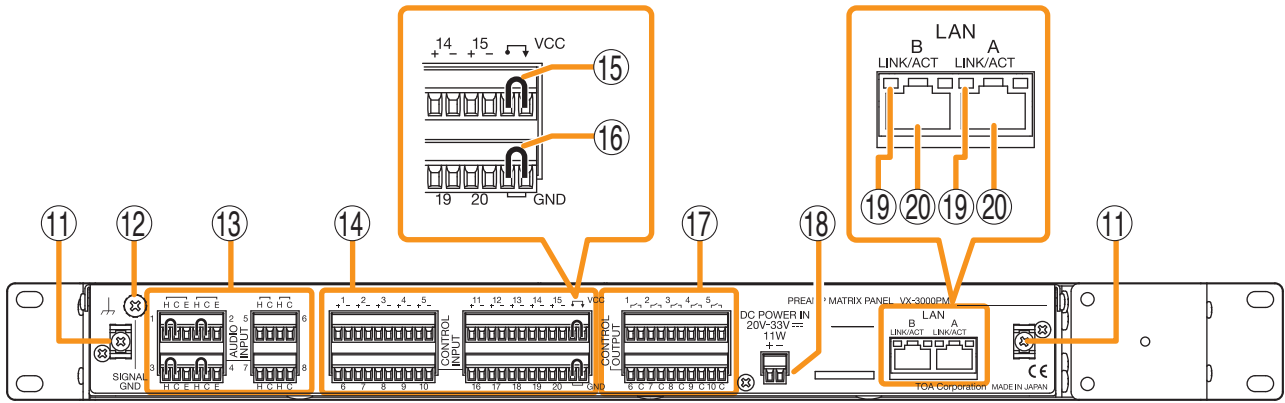

11. Cable tie fixture

Pass the cable tie through this fixture, then bundle and secure the cables connected to each terminal together with the cable tie.

12. Signal ground terminal

Be sure to ground this terminal for surge protection.
Note: This terminal is not for protective ground.

13. Audio input terminals (1 – 8)

Connect audio signals such as audio player.
 The Audio input terminals 1 through 4 are balanced inputs, of which input signal level can be set by the input level setting switch inside the front panel.
 The Audio input terminals 5 through 8 are unbalanced inputs, each of which input signal level is fixed as shown below.

Audio input terminals 5 and 6: -20 dB*
 Audio input terminals 7 and 8: 0 dB*

* 0 dB = 1 V

Note

The Audio input terminals 5 through 8 are provided for connecting audio source devices installed in the equipment rack.

14. Control input terminals (1 – 20)

These terminals receive activation signals from external equipment to enable external VX-3000 system control.

Note

The "-" (negative) terminals of the Control input terminals 1 through 20 are interconnected.

15. Power feed jumper

A jumper is installed on the removable terminal plug by default. Power is supplied from the unit's inside to the circuit of the Control input terminals 1 through 20 (14). Detaching this jumper disconnects the internal power supply, necessitating an external power supply instead. (See "Operation of the power feed jumper and the isolation jumper" illustrated below.)

16. Isolation jumper

With the jumper installed, "-" (negative) terminals of the Control input terminals 1 through 20 (14) are connected to the power supply (Ground). Detaching this jumper disconnects the "-" terminals from the unit, isolating the unit. (See "Operation of the power feed jumper and the isolation jumper" illustrated below.)

[Operation of the power feed jumper and the isolation jumper]

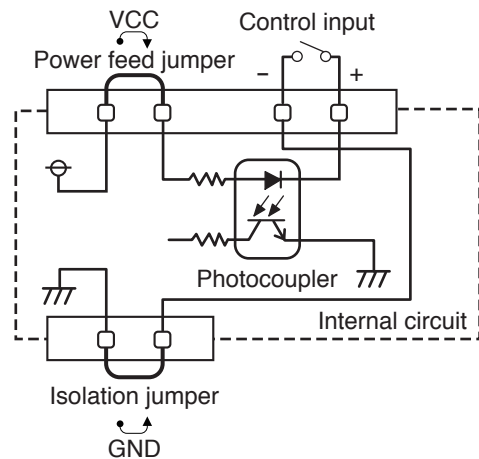

17. Control output terminals

These terminals permit the VX-3000 system to control other connected external equipment.

• **Control output terminals 1 – 5**

Relay contact outputs (Form A contacts)

Withstand voltage: 30 V DC

Allowable current: 1 A

• **Control output terminals 6 – 10**

Open collector outputs (polarized)

Withstand voltage: 30 V DC

Allowable current: 100 mA

Note

The "C" terminals of the Control output terminals 6 through 10 are interconnected.

18. DC Power input terminals

Power is supplied to this terminal from the VX-3000DS or VX-3150DS Power supply manager or the AD-246 AC Adapter.

19. LINK/ACT indicators

Indicates the connection status of the LAN connection terminal.

Lights or flashes when the connection is correct.

Remains unlit when no connection is established.

20. LAN link connectors

Connect the VX-3000 system components or switching hubs. (See p. 3-83 "VX-3000 Unit's LAN Link Connector Connection.")

5. VX-3000CT CONTROL PANEL

- The VX-3000CT is a 1U size* Control panel mountable in an EIA standard equipment rack.
- Operation such as the activation of general broadcast and the input/output volume control can be performed by connecting the VX-3000CT to the VX-3000F via network. Up to 2 VX-3000CT units can be connected to a single VX-3000F unit.
- The VX-3000CT unit is equipped with 9 function keys and 8 volume controls, to each of which a function can be assigned using the VX-3000 Setting Software.

* 1U size = 44.5 mm (standard size)

[Front]

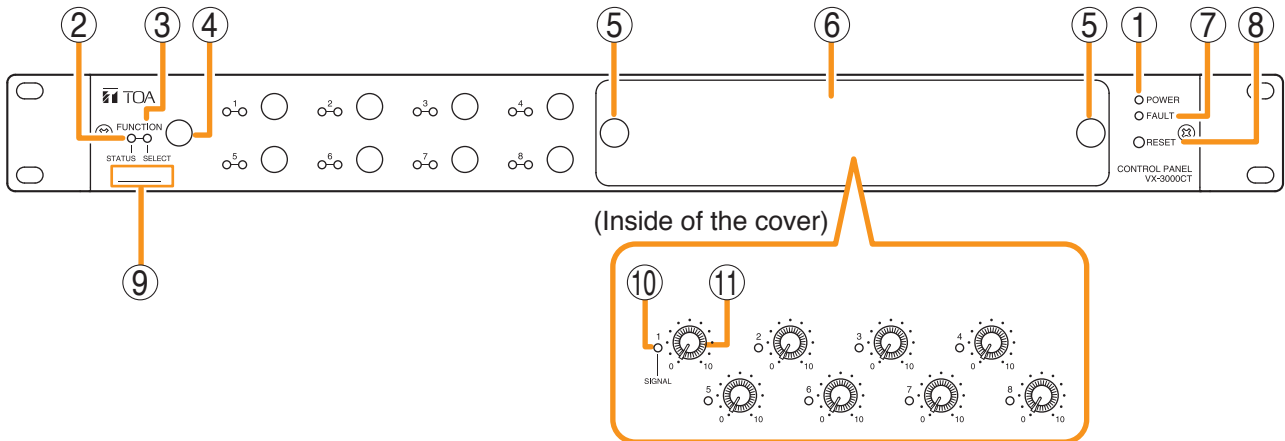

1. Power indicator (Green)

Lights when power is being supplied.

2. Status indicator (Yellow/Green)

Lights yellow or green, or goes off in synchronization with the operation state of the function key.

(See the separate Operating Instructions, "INDICATOR STATUS OF THE CONTROL PANEL AND REMOTE MICROPHONES.")

3. Selection indicator (Green)

Lights or goes off in synchronization with the operation state of the function key.

(See the separate Operating Instructions, "INDICATOR STATUS OF THE CONTROL PANEL AND REMOTE MICROPHONES.")

4. Function keys

Pressing a specific function key executes the function that has been assigned to that key by the VX-3000 Setting Software. Assignment of functions to specific keys is done using the VX-3000 Setting Software.

(See the separate Setting Software Instructions, "VX-3000CT Setting.")

5. Volume control section cover knobs

The volume control section cover can be removed by pulling the both knobs.

6. Volume control section cover

7. Fault indicator (Yellow)

Lights when an equipment error is detected.

8. Reset key

Resets the VX-3000CT when this key is pressed.

9. MAC address

This is the MAC address* for the unit. Since the relationship of each unit location to its MAC address is established when setting the network attributes, keep track of this relationship for later use.

* The unit's MAC address consists of 12 hyphenated alphanumeric characters.

10. Signal indicator (Green)

Indicates the status of the input or output assigned to the Volume control (11). If the indicator functions as input signal indicator, it lights when the audio level of the input channel assigned to the Volume control (11) is -25 dB or more regardless of the volume control value.

If the indicator functions as output signal indicator, it lights when the audio level of the set individual output zone is -25 dB or more.

The setting can be performed using the VX-3000 Setting Software.

(See the separate Setting Software Instructions, "VX-3000CT Setting.")

11. Volume control knobs

Adjusts the volume level of the VX-3000F's audio input or audio output in the range of $-\infty$ to 0 dB. The volume decreases as the knob is rotated clockwise, and increases as the knob is rotated counterclockwise.

Which volume level of the input channel or the output zone is to be adjusted can be assigned to the volume control using the VX-3000 Setting Software.

(See the separate Setting Software Instructions, "VX-3000CT Setting.")

[Rear]

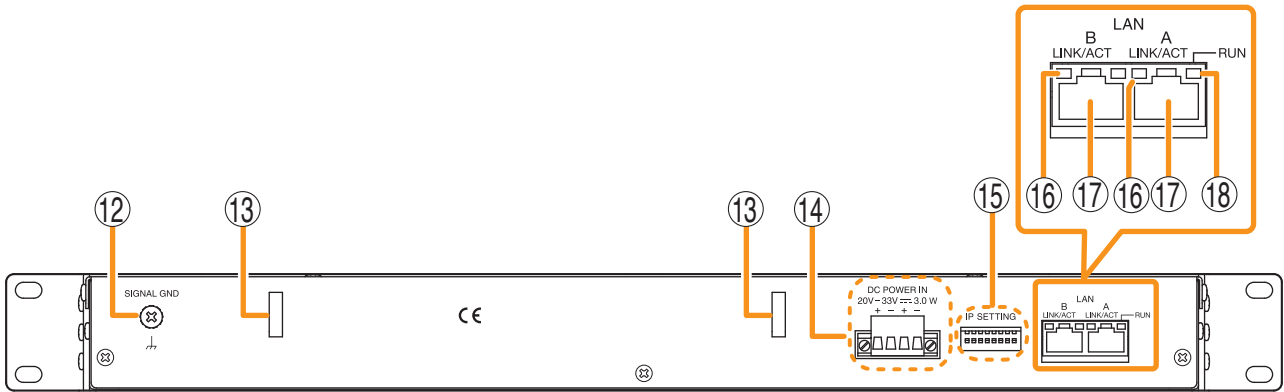

12. Signal ground terminal

Be sure to ground this terminal for surge protection. **Note:** This terminal is not for protective ground.

13. Cord clamps

Secures the power cord. (See p. 3-95.)

14. DC Power input terminals

Power is supplied to this terminal from the VX-3000DS or VX-3150DS Power supply manager or the AD-246 AC Adapter.

15. IP address setting switch

Sets the unit's IP address.



Note: Switches 1 through 8 numbered from left to right.

(Factory default setting: All set to OFF)

• Switch 1

Sets whether to enable or disable IP address setting by the IP address setting switch.

ON: Enables the IP address set by the IP address setting switch.

OFF: Disables the IP address set by the IP address setting switch and enables the one set using the VX-3000 Setting Software.

• Switches 2 – 8

Set the IP address by ON/OFF combination of 7 switches. (See p. 3-14.)

Notes

- If you have reset the IP address after power-on, be sure to restart the unit.
- The IP address setting switch allows the IP address to be set only in the range of "192.168.14.111" to "192.168.14.200". If you wish to set IP address out of this range, set it using the VX-3000 Setting Software. (See the separate Setting Software Instructions, "UNIT DETECTION AND NETWORK SETTINGS.")

16. LINK/ACT indicators

Indicates the connection status of the LAN connection terminal.

Lights or flashes when the connection is correct. Remains unlit when no connection is established.

17. LAN link connectors

Connect the VX-3000 system components or switching hubs. (See p. 3-83 "VX-3000 Unit's LAN Link Connector Connection.")

18. RUN indicator

Continuously flashes when the unit's CPU is operating normally.

6. RM-200SF FIREMAN'S MICROPHONE

- The RM-200SF Fireman's Microphone features 3 function keys, 1 emergency key, 1 talk key, and the indicator lamps associated with these keys. Functions are assigned to the function keys using the VX-3000 Setting Software.
- Specially designed for both emergency and general purpose broadcast applications, the Fireman's Microphone can be used for push-button zone selection and microphone broadcasts.
- VX-3000 setting software permits desired functions to be assigned to individual Function keys (equipped with 2 LED indicators).
- Up to 4 RM-320F Remote Microphone Extension units can be used with each RM-200SF Remote Microphone.
- Up to 2 RM-200SF Fireman's Microphones can be connected within a VX-3000F.
- The CPU switch enables all-zone emergency broadcasts from the RM-200SF Fireman's Microphone, even when the CPU malfunctions.
- Failures of Emergency buttons and signal (both control and audio) path between the microphone (including the internal microphone element) and the VX-3000F are automatically detected.

[Front]

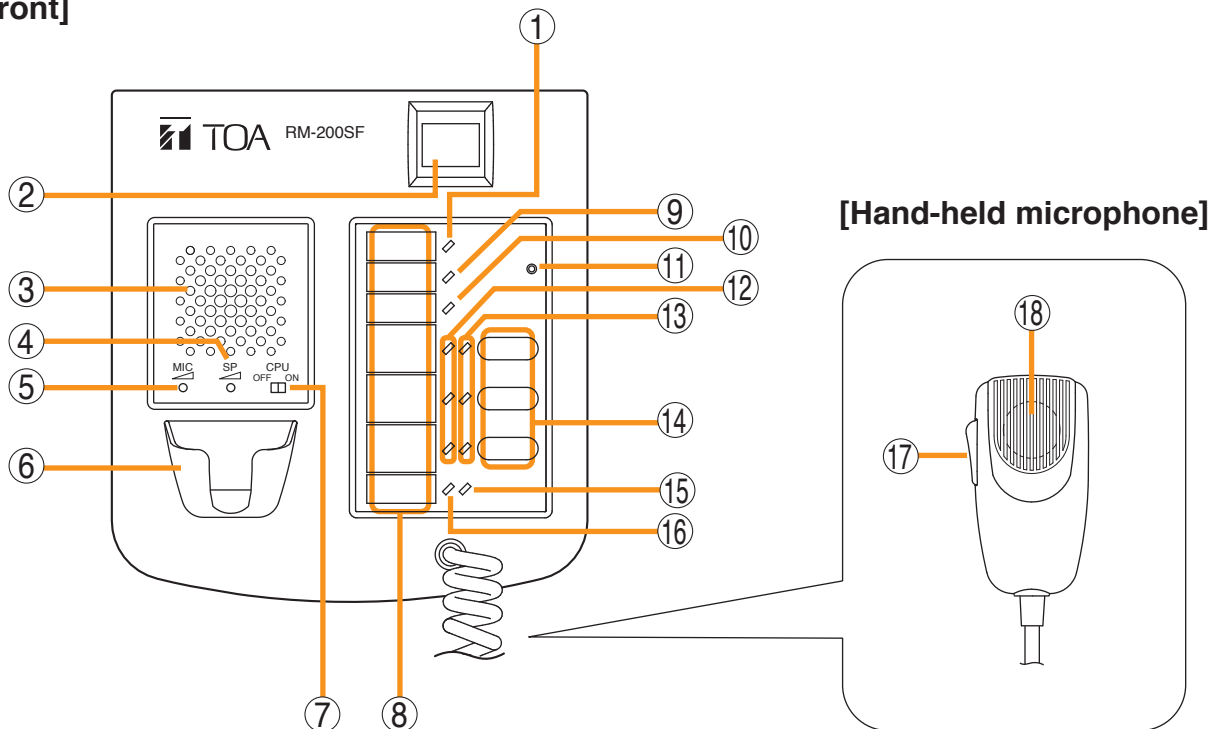

1. Power indicator (Green)

Lights when the power is turned on.

2. Emergency key

Assign the function concerning the emergency broadcast to this key using the VX-3000 Setting Software.

This key lights or flashes depending on the assigned function.

3. Monitor speaker

Used to monitor current broadcasts.

4. Monitor speaker volume control

Adjusts the volume of the built-in Monitor speaker (3).

5. Microphone volume control

Adjusts the input sensitivity of the Hand-held Microphone.

6. Microphone hanger

Used to hold the unit's Hand-held Microphone.

7. CPU switch

Normally set to ON. (Factory-preset: ON)

Setting this switch to OFF in combination with the DIP switch (20) setting on the bottom surface allows the all-zone emergency broadcast to be made using a hand-held microphone by way of analog transmission not via the CPU control.

8. Indication label insert slot

The label can be printed using the VX-3000 Setting Software. (See the separate Setting Software Instructions, "PRINTING LABELS FOR REMOTE MICROPHONES.")

9. Failure indicator (Yellow/Red)

Flashes yellow if some problem within the system is detected.

This indicator will light yellow if the signal to the VX-3000F to which the RM-200SF is connected is interrupted for 5 seconds or more.

Lights red when the unit is placed in reset state by pressing the Reset Switch (11).

10. CPU indicator (Red)

Lights red when any one of the CPU switches on the RM-200SFs connected within the system is set to OFF or when the all-zone emergency broadcasts is being made by any one of the RM-300Xs connected within the system.

11. Reset switch

Used to reactivate the RM-200SF unit.

Holding down both this switch and the R3 key of the Function keys (14) for 2 seconds or more causes the Failure Indicator (9) to light red, placing the RM-200SF in reset state.

12. Status indicators (Red/Yellow/Green)

Light, flash, or go off depending on the current operation state of function keys, failure state or emergency state. (See the separate Operating Instructions, "INDICATOR STATUS OF REMOTE MICROPHONES.")

13. Selection indicators (Green)

Light or go off depending on the current operation state of function keys. (See the separate Operating Instructions, "INDICATOR STATUS OF REMOTE MICROPHONES.")

14. Function keys (R1 – R3)

Positioned in top-down order (R1, R2, R3). Pressing a specific function key executes the function that has been assigned to that key by the VX-3000 Setting Software. Assignment of functions to specific keys is done using the VX-3000 Setting Software. (See the separate Setting Software Instructions, "RM Event Settings.")

15. Microphone indicator (Green)

Lights or goes off depending on the current operation state of the Talk key.

16. Broadcast Status Indicator (Yellow/Green)

Lights, flashes, or goes off depending on the current operation state of the Talk key.

17. Talk key

Press this key to broadcast a voice announcement. It must be pressed continuously for the duration of the broadcast.

The talk key operation method is fixed to "PTT," and can not be changed.

18. Microphone

Used for voice announcements.

[Side]

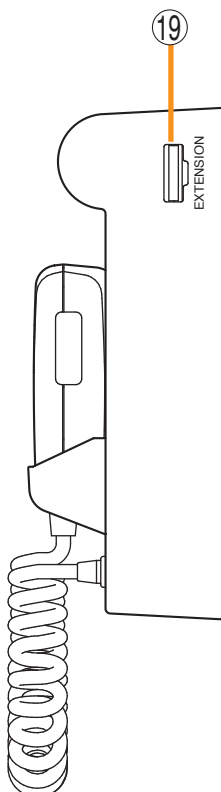

19. RM-320F connection terminal

Connect the RM-320F Remote Microphone Extension unit to this terminal. (See p. 2-21.)

[Rear]

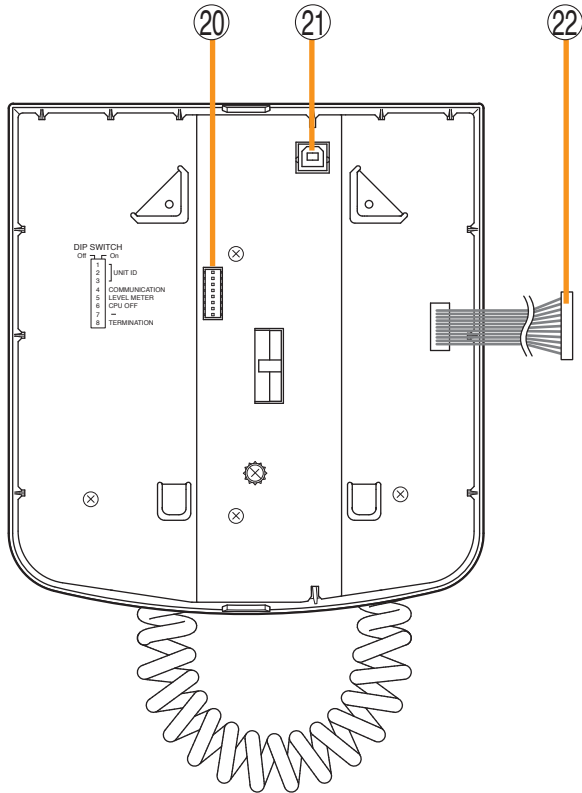

[Wall mount bracket unit (Accessory)]

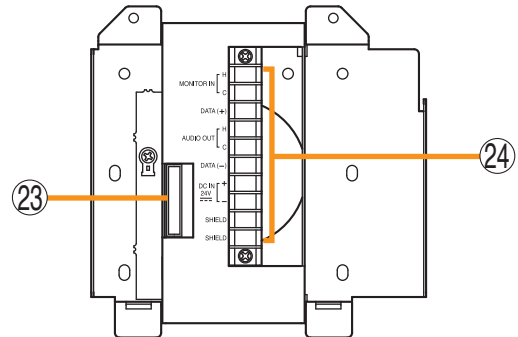

20. DIP switch

Used for setting the RM-200SF unit.

• **Switches 1 – 3 [UNIT ID]**

Set the RM-200SF's device number (ID number).
(See p. 3-19.)

• **Switch 4 [COMMUNICATION]**

Not used.
Normally set to OFF.

• **Switch 5 [LEVEL METER]**

Changes a broadcast status indicator (12) into an output signal level indicator. (See p. 3-22.)

• **Switch 6 [CPU off]**

Sets whether the CPU off function (all-zone emergency broadcasts) is enabled or disabled.
(See p. 3-30.)

• **Switch 7**

Not used. Normally set to OFF .

• **Switch 8 [TERMINATION]**

Sets the termination of the RM communication line (Control communication lines between the VX-3000F and the RM-200SF). Normally set to OFF. (See p. 3-31.)

Note

By default, switches 1 – 5 and 7 are set to OFF, and switches 6 and 8 to ON.

21. USB terminal

Not used.

22. Extension connector

Connect this connector to the extension connector (23) of the Wall Mount Bracket Unit (accessory).
(See p. 3-42.)

23. Extension connector

Connect the cable extending from the RM-200SF to this connector. (See p. 3-42.)

24. Screw terminal block

• **Audio monitor line [MONITOR IN]**

Connect the audio monitor input line from the VX-3000F to the RM-200SF.

• **RM communication line [DATA]**

Connect the control communication line between the VX-3000F and the RM-200SF.

• **Audio output line [AUDIO OUT]**

Connect the audio signal output line from the RM-200SF to the VX-3000F.

• **DC power input [DC IN 24 V]**

Used to supply DC power from the VX-3000F to the RM-200SF.

• **Shield [SHIELD]**

Used for the control line through which the VX-3000F system confirms the RM-200SF's connection.

Be sure to connect at least one of two terminals to the VX-3000F.

7. RM-320F FIREMAN'S MICROPHONE EXTENSION

Each connected RM-320F Extension unit adds 20 Function keys to the base RM-200SF.

[Front]

[Side]

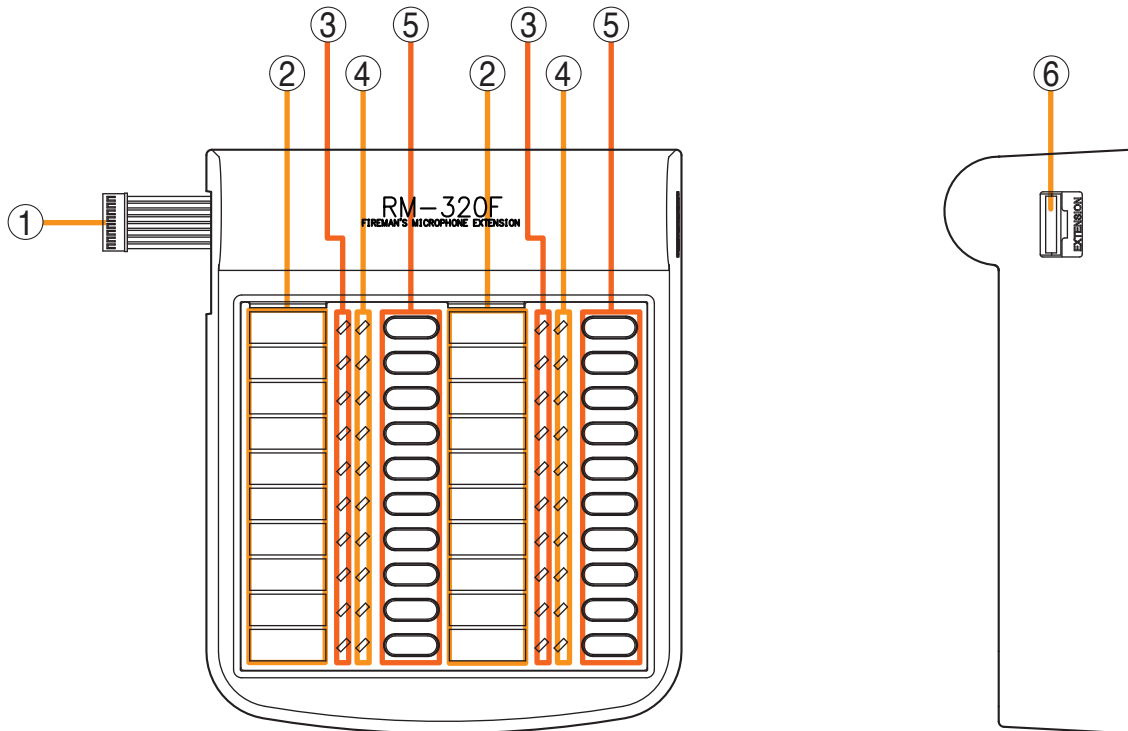

1. Connection cable

Used for connection to the RM-200SF or other RM-320F.

2. Indication label insert slot

The label can be printed using the VX-3000 Setting Software. (See the separate Setting Software Instructions, "PRINTING LABELS FOR REMOTE MICROPHONES.")

3. Status indicators (Red/Yellow/Green)

Light, flash, or go off depending on the current operation state of function keys.

4. Selection indicators (Green)

Light or go off depending on the current operation state of function keys.

5. Function keys (1 – 20)

Keys are numbered from 1 to 10 from upper left to bottom and from 11 to 20 from upper right to bottom.

Pressing a specific function key executes the function that has been assigned to that key by the VX-3000 Setting Software. Assignment of functions to specific keys is done using the VX-3000 Setting Software.

(See the separate Setting Software Instructions, "RM Event Settings.")

6. RM connection terminal [EXTENSION]

Connect the other RM-320F to this terminal.

8. RM-300X REMOTE MICROPHONE

- The RM-300X Remote Microphone features 13 function keys, 1 covered key, 1 talk key, and the indicator lamps associated with these. Functions are assigned to the function keys using the VX-3000 Setting Software.
- VX-3000 setting software permits desired functions to be assigned to individual Function keys (equipped with 2 LED indicators).
- Connecting RM-210F Remote Microphone Extension (maximum 7) to the RM-300X expands the number of function keys and indicators in blocks of 10.
- Up to 8 RM-300X Remote Microphones can be connected within a VX-3000F.
- The DIP switch setting enables all-zone emergency broadcasts from the RM-300X Remote Microphone, even when the CPU malfunctions.

[Top]

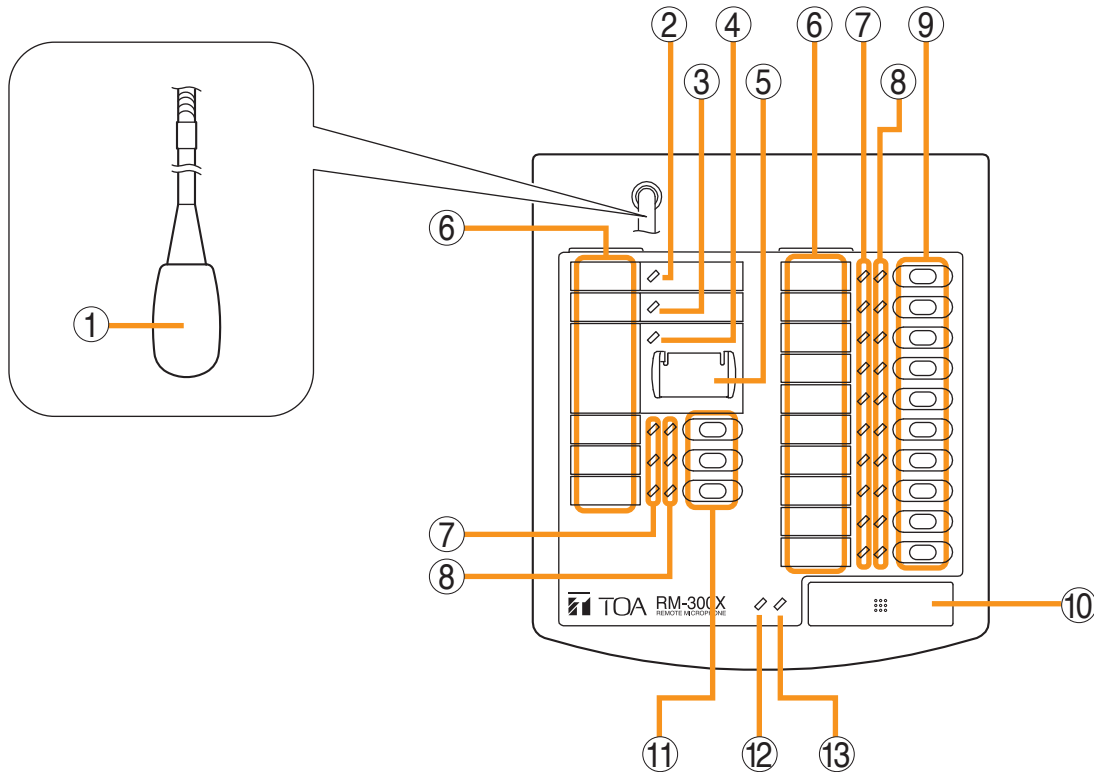

1. Microphone

Used for voice announcements.

2. Power indicator (Green)

Lights when the power is turned on.

3. Failure indicator (Yellow/Red)

Flashes yellow if some problem within the system is detected.

This indicator will light yellow if the signal to the VX-3000F to which the RM-300X is connected is interrupted for 5 seconds or more.

This indicator will light red while the all-zone emergency broadcasts is being made (p. 3-30) or the RM-300X is in the reset process.

4. Emergency indicator (Red)

Lights or flashes depending on the function assigned to the Emergency key.

5. Emergency/all-zone emergency broadcast key (Covered)

[Function concerning the emergency broadcast]
Assign the function concerning the emergency broadcast to this key using the VX-3000 Setting Software.

[Function concerning the all-zone emergency broadcast]

Independently of settings made by the VX-3000 Setting Software, holding down this key for 4 seconds or more in combination with DIP switch (14) setting causes the CPU to be bypassed, enabling the all-zone emergency broadcast to be made by way of analog transmissions. (See p. 3-30.)

6. Indication label insert slots

Labels can be printed using the VX-3000 Setting Software. (See the separate Setting Software Instructions, "PRINTING LABELS FOR REMOTE MICROPHONES.")

7. Status indicators (Red/Yellow/Green)

Light, flash, or go off depending on the current operation state of function keys, failure state or emergency state. (See the separate Operating Instructions, "INDICATOR STATUS OF REMOTE MICROPHONES.")

8. Selection indicators (Green)

Light or go off depending on the current operation state of function keys. (See the separate Operating Instructions, "INDICATOR STATUS OF REMOTE MICROPHONES.")

9. Function keys (R1 – R10)

Positioned in top-down order (R1, R2 ... R10). Pressing a specific function key executes the function that has been assigned to that key by the VX-3000 Setting Software.

Assignment of functions to specific keys is done using the VX-3000 Setting Software. (See the separate Setting Software Instructions, "RM Event Settings.")

10. Talk key

Press this key to broadcast a voice announcement. If the Talk key is set to "PTT" ("press-to-talk") mode, then it must be pressed continuously for the duration of the broadcast.

If the Talk key is set to "Lock" mode, then it must be pressed once to turn the microphone on at the beginning of a broadcast, then pressed again to turn the microphone off once the broadcast is finished.

The microphone can also be set to sound a chime at the beginning and/or end of each broadcast.

The Talk key mode ("PTT" or "Lock") and the chime function are set using the VX-3000 Setting Software. (See the separate Setting Software Instructions, "Unit Configuration Settings.")

11. Function keys (L1 – L3)

Positioned in top-down order (L1, L2, L3).

These keys operate in the same manner as the Function keys (R1 – R10) (9).

12. Broadcast status indicator (Yellow/Green)

Lights, flashes, or goes off depending on the current operation state of the Talk key.

13. Microphone indicator (Green)

Lights or goes off depending on the current operation state of the Talk key. Flashes while the chime is being activated.

[Side]

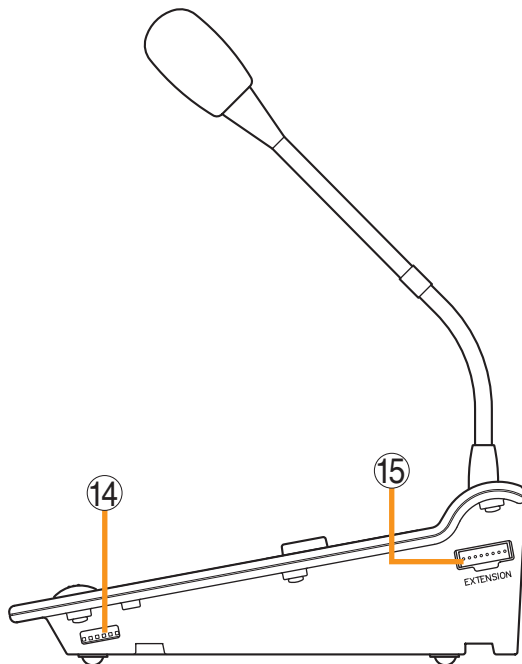

14. DIP switch

Used for setting the RM-300X unit.

• **Switches 1 – 3**

Sets the RM-300X's device number (ID number). (See p. 3-19.)

• **Switch 4**

Changes a broadcast status indicator (12) into an output signal level indicator. (See p. 3-22.)

• **Switch 5**

Sets whether the CPU off function (all-zone emergency broadcasts) is enabled or disabled. (See p. 3-30.)

• **Switch 6**

Not used.

Note

By default, switches 1 – 4 and 6 are set to OFF and switch 5 to ON.

15. RM-210F connection terminal [EXTENSION]

Directly connect the RM-210F Remote Microphone Extension unit to this terminal.

(See p. 3-45.)

[Rear]

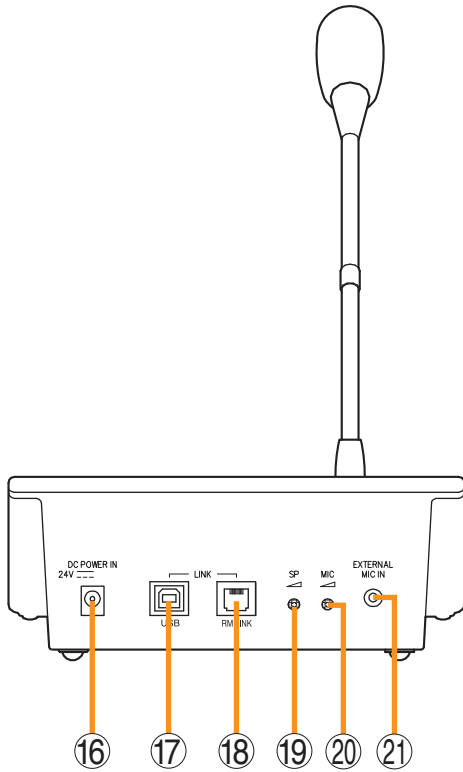

16. Power input terminal [DC POWER IN]

Connect an optional AD-246 AC adapter to this terminal when extending cable length.

(See p. 3-72.)

Power is usually supplied to the RM-300X and RM-210F from the VX-3000F.

17. USB terminal

Not used.

18. RM link connector

Used to connect an VX-3000F via a STP Category 5 cable.

19. Speaker volume control

Adjusts the volume of the built-in speaker.

20. Microphone volume control

Adjusts the volume of the microphone (1) and the external microphone connected via the external microphone input terminal (21).

21. External microphone input terminal

Audio input jack to use as an external microphone input*¹ or AUX input

Jumper settings on the circuit board must be changed depending on the input sources.

(See p. 3-32, p. 3-34.)

[Specifications used as External microphone input]

-40 dB*², 2.2 kΩ, unbalanced, mini-jack, and phantom power.

[Specifications used as AUX input]

-20 dB*², 4.7 kΩ, unbalanced, mini-jack.

*¹ The WH-4000A, YP-M101, or YP-M301 can be used for the external microphone.

*² 0 dB = 1 V

Note

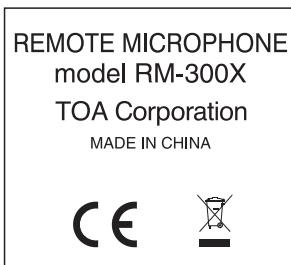

The Equipment marking label shown at left is affixed to the unit's bottom side.

9. RM-210F REMOTE MICROPHONE EXTENSION

Each connected RM-210F Extension unit adds 10 Function keys to the base RM-300X.

[Top]

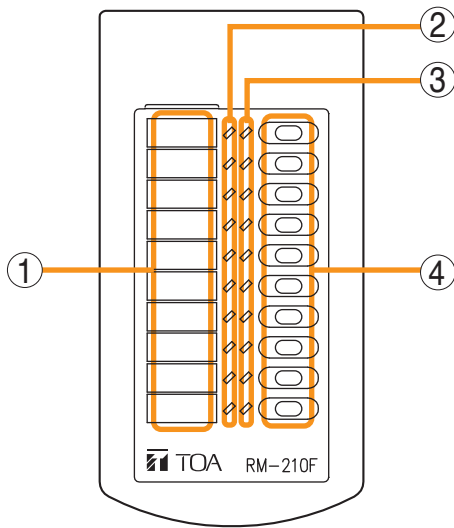

1. Indication label insert slot

The label can be printed using the VX-3000 Setting Software. (See the separate Setting Software Instructions, "PRINTING LABELS FOR REMOTE MICROPHONES.")

2. Status indicators (Red/Yellow/Green)

Light, flash, or go off depending on the current operation state of function keys.

3. Selection indicators (Green)

Light or go off depending on the current operation state of function keys.

4. Function keys (1 – 10)

Positioned in top-down order (1, 2 ... 10).

Pressing a specific function key executes the function that has been assigned to that key by the VX-3000 Setting Software.

Assignment of functions to specific keys is done using the VX-3000 Setting Software. (See the separate Setting Software Instructions, "RM Event Settings.")

[Side]

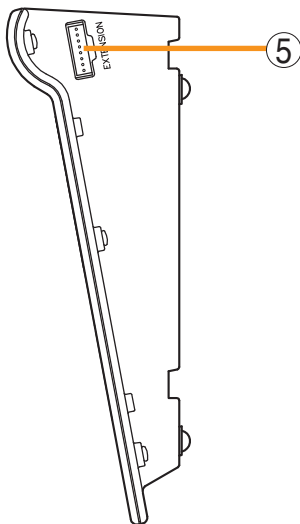

5. RM connection terminal [EXTENSION]

Connect the RM-300X or other RM-210F to this terminal. (See p. 3-45.)

Note

Another same terminal is on the other side.

Note

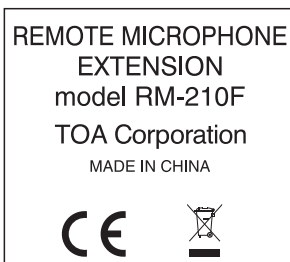

The Equipment marking label shown at left is affixed to the unit's bottom side.

10. RM-200RJ TERMINAL UNIT

Convert the RJ45 connector into a screw terminal block. It is used to connect between a trunk cable (such as CPEV cable) and a feeder cable (such as LAN cable) in wiring a remote microphone.

[Front]

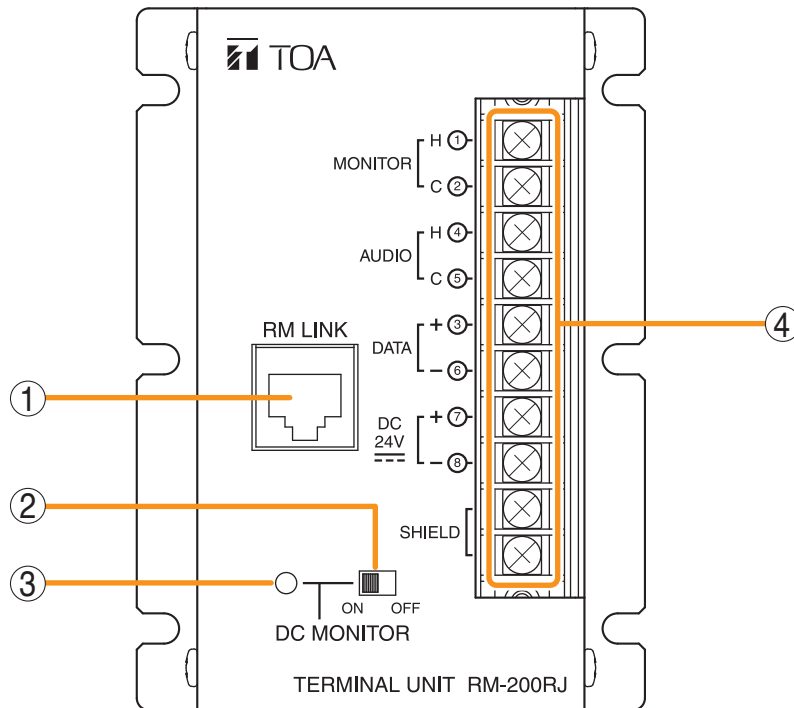

1. RM link terminal

Connect to the RS link terminal of the VX-3000F or RM link terminal of the RM-300X or RM-500.

2. Power monitor switch

Set to ON to enable the Power monitor indicator. (Factory-preset: ON)

3. Power monitor indicator (Green)

Lights if the source voltage of the DC power input exceeds the minimum operating voltage of the RM-300X or RM-500 when the Power Monitor Switch is set to ON.

4. Screw terminal block

The Screw terminal block and RM link terminal are internally connected in parallel. Numbers 1 through 8 indicated beside each terminal correspond to the pin numbers of the RJ45 connector to be connected to the RM link terminal (1).

• Audio monitor terminals [MONITOR H/C]

Connect the audio monitor line from the VX-3000F to the RM-300X.

• Audio output terminals [AUDIO H/C]

Connect the audio output line from the RM-300X or RM-500 to the VX-3000F.

• RM communication terminals [DATA +/-]

Connect the control communication line between the VX-3000F and the RM-300X or RM-500.

• DC power input terminals [DC 24 V +/-]

Used to supply DC power from the VX-3000F to the RM-300X or RM-500.

• Shield terminals [SHIELD]

Connect the shield wires for noise reduction or for system control.

Be sure to connect at least one shield wire.

11. RM-500 REMOTE MICROPHONE

- The RM-500 is a desktop type remote microphone designed for general broadcast.
- Equipped with an LCD screen, it can display up to 80 function names registered in advance, allowing these functions to be executed with the key operation.
- Pressing the AUX key enables the control of only the external audio signals.
- The speech intelligibility function makes it easier to hear the microphone announcements even in noisy environments, and also allows the microphone to pick up the audio signals at an appropriate level even if speaking too close to or too far from it.
- Can be mounted on the wall by using an optional wall mounting bracket.

[Top]

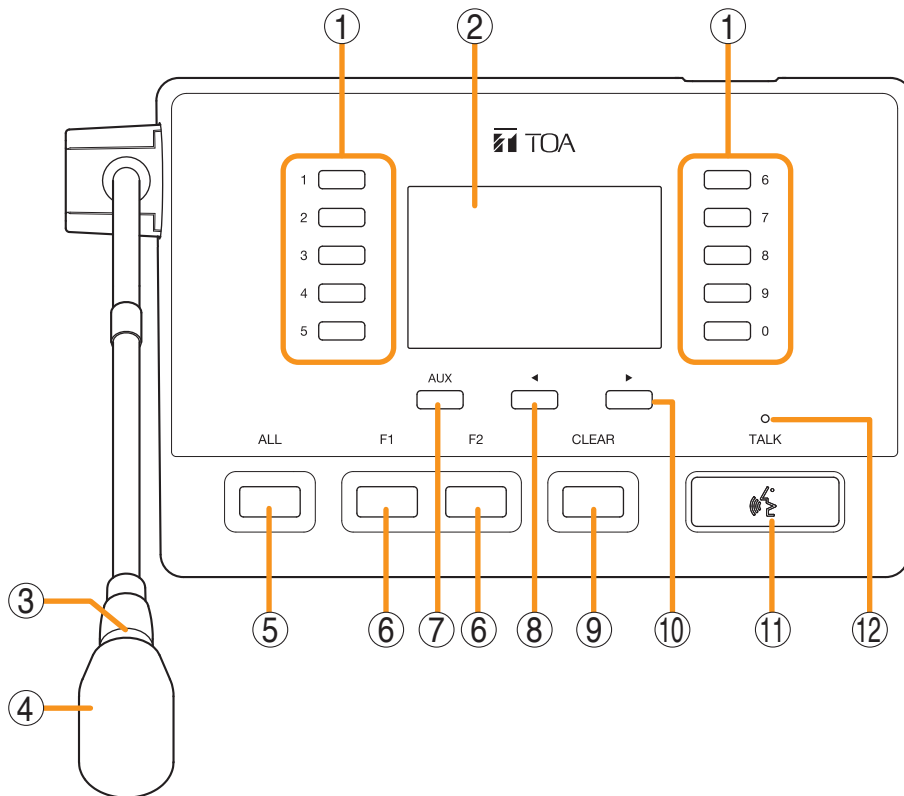

1. Numeric keys

Normally, select the item number displayed on the LCD screen. The functions set with the VX-3000 Setting software can be executed.

When the menu screen is displayed, these keys are used to select the menu item number or the option number.

2. LCD screen

Normally, displays a list of the set functions and the status of the broadcast or function.

Shifting Switch 6 of the Setting switch (16) to the ON position switches the mode to the direct selection, displaying the line number registration screen.

Shifting Switch 7 of the Setting switch (16) to the ON position switches the screen to the menu display.

3. Microphone indicator (green)

Lights during the microphone broadcasts. However, it does not light when announcements are being broadcast from the microphone

connected to the AUX input terminal.

You can also set it to OFF by the system setting. (See p. 3-24 "Setting The RM-500's Menu.")

4. Microphone

Used for making general broadcasts.

The microphone volume can be adjusted with the Microphone volume control (15).

5. ALL key

Selects the preset zones.

6. F1/F2 key

The functions set with the VX-3000 Setting software can be executed.

7. AUX key

Press this key to broadcast the audio signals fed to the AUX input terminal (20).

When the menu screen is displayed, pressing this key executes the operation as shown by the guide displayed in the lower left of the screen.

8. ◀ key

Press this key to move to the previous page from the current page displayed on the LCD screen. When the menu screen or the line number registration screen is displayed, pressing this key executes the operation as shown by the guide displayed in the lower center of the screen.

9. Clear key

Terminates the broadcast when pressed while broadcast is in progress. Cancels the selection for all zones being selected in normal mode on the LCD screen.

10. ▶ key

Press this key to move to the next page from the current page displayed on the LCD screen. When the menu screen or the line number registration screen is displayed, pressing this key executes the operation as shown by the guide displayed in the lower center of the screen.

11. Talk key

Press this key to broadcast a voice announcement. Set the key operation mode to either PTT or Lock at the system setup.

If the Talk key is set to "PTT" ("press-to-talk") mode, then it must be pressed continuously for the duration of the broadcast.

If the Talk key is set to "Lock" mode, then it must be pressed once to turn the microphone on at the beginning of a broadcast, then pressed again to turn the microphone off once the broadcast is finished.

(See the separate Setting Software Instructions, "Unit Configuration Settings.")

12. Talk indicator (green)

Lights or goes off depending on the current operation state of the Talk key.

[Left side]

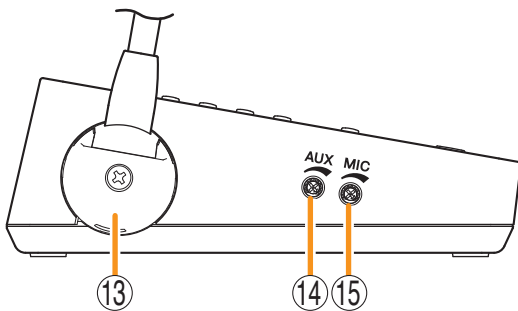

13. Microphone fixing cover

A cover to fix the microphone.

For wall hanging installation, remove this cover and change the orientation of the microphone.

(See p. 3-49 "Changing the orientation of the microphone.")

14. AUX volume control

Adjusts the volume of AUX input.

Rotate this control clockwise to increase the volume level and counterclockwise to decrease it. The input level can be checked on the menu screen.

(See p. 3-24 "Setting The RM-500's Menu.")

15. Microphone volume control

Adjusts the microphone volume.

Rotate this control clockwise to increase the volume level and counterclockwise to decrease it. The input level can be checked on the menu screen.

(See p. 3-24 "Setting The RM-500's Menu.")

[Bottom]

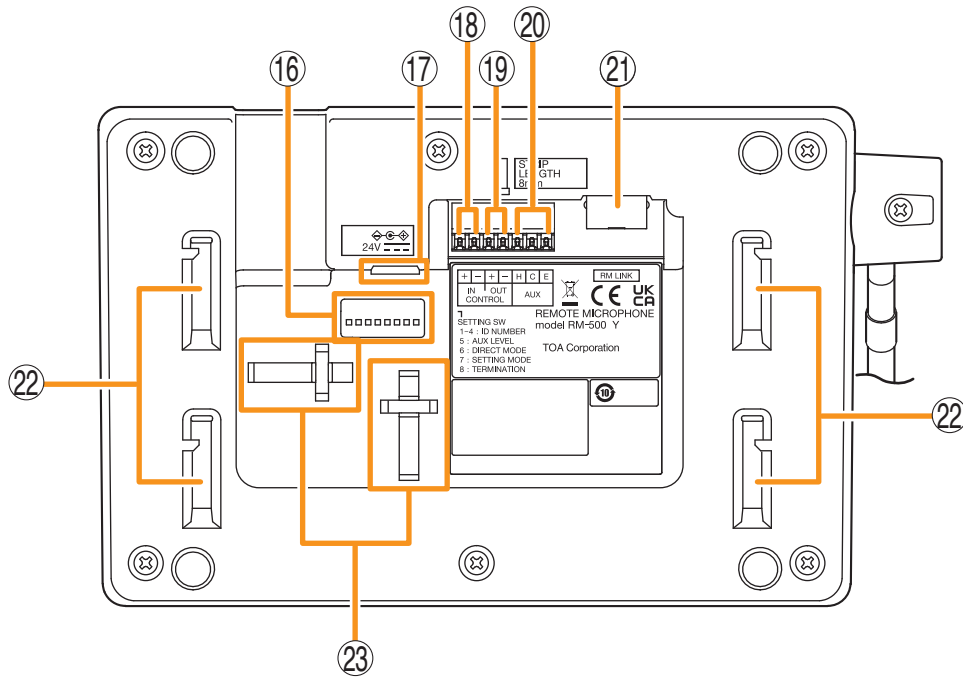

16. Setting switch

- **Switches 1 – 4 [ID NUMBER]**
Sets the RM-500's device number (ID number).
(See p. 3-19 "The ID Number Settings (RM-200F and RM-300X: Switches 1 – 3 operation or RM-500: Switches 2 – 4 operation).")
- **Switch 5 [AUX LEVEL]**
Sets the input level of the AUX input terminal.
OFF: Line level
ON: Microphone level
(See p. 3-33 "Setting the Level of the AUX Input Terminal (RM-500 Only).")
- **Switch 6 [DIRECT MODE]**
Set to ON when using the direct selection mode.
(See p. 3-33 "Setting for using the direct selection function (RM-500 Only)" and the separate Operating Instructions, "Making Microphone Announcements in Direct Selection Mode.")
- **Switch 7 [SETTING MODE]**
Set to ON when performing RM-500 setting.
(See p. 3-24 "Setting The RM-500's Menu.")
- **Switch 8 [TERMINATION]**
Set the termination of the line when connecting multiple general-use remote microphones to the VX-3000F.
(See p. 3-31 "Termination Setting (RM-200SF, RM-500: Switch 8 operation).")

Note

By default, switches 1 – 7 are set to OFF, and switch 8 to ON.

17. AC adapter connection terminal

Connect an optional AD-246 AC adapter to this terminal when extending cable length. Power is usually supplied to the RM-500 from the

VX-3000F.

(See p. 3-72 "When power is supplied from the AC adapter.")

18. Control input terminal

You can assign functions such as general pattern broadcast and emergency input broadcast to this terminal.

(See the separate Setting Software Instructions, "Control Input Event Setting.")

No-voltage make contact
Open voltage: 30 V DC
Short-circuit current: 10 mA

19. Control output terminal

When wishing to output the system status to the external device, connect this terminal to the external device.

(See the separate Setting Software Instructions, "Control Output Pattern Setting.")

Open collector outputs (polarized)
Withstand voltage: 30 V DC
Control current: 35 mA

20. AUX input terminal

When set to Line level input:

–20 dB*, 10 kΩ, unbalanced

When set to Microphone level input:

–60 dB*, 2.2 kΩ, unbalanced

The input level is set by Switch 5 of the Setting switch (16).

Broadcasts can be made through the AUX input by connecting such external equipment as a sound source unit or microphone to this terminal. It does not supply the phantom power.

* 0 dB = 1 V

21. RM link connector

Used to connect an VX-3000F via a STP Category 5 cable.

22. Wall mounting bracket mounting holes

Used when installing the RM-500 on the wall in conjunction with the optional wall mounting bracket.

(See p. 3-50 "Hanging the RM-500 on the wall.")

23. Wiring cable fixing holes

Used to bind the wiring cables.

(See p. 3-58 "Connecting the Cable to the Push-in Terminal Block.")

12. SX-200EL END OF LINE UNIT

Connected at the end of speaker line, the SX-200EL will detect abnormalities such as short-circuit, open-circuit, and ground fault of a speaker line.

Notes

- The SX-200EL is designed for exclusive use with the VX-3004F.
- The SX-200EL is sold only in Europe.

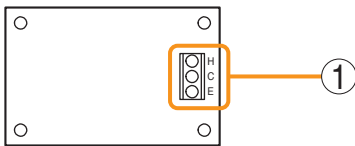

1. Speaker line connection terminal

Connect the EOL unit to the end of the speakerline. Be sure to connect the speaker's shield cable to the E terminal of EOL unit, and the other end of the cable to the E terminal of the VX-3004F unit's speaker output terminal.

13. VM-300SV END OF LINE UNIT

Speaker line failure can be detected when an EOL unit is connected between the speaker line end and the control input terminal of the VX-3008F and VX-3016F.

Note

The VM-300SV is designed for exclusive use with the VX-3008F and VX-3016F.

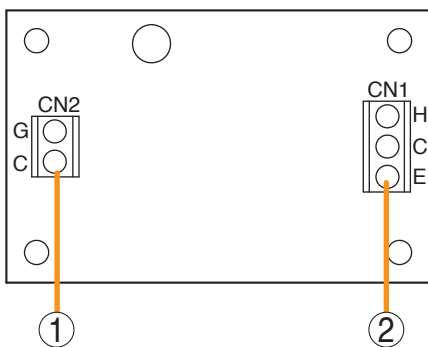

1. Control line connection screw terminal (CN 2)

Connect to the VX-3008F/3016F unit's control input terminal.

2. Speaker line connection screw terminal (CN 1)

Connect to the speaker line end.

Chapter 3

INSTALLATION AND SETTING PROCEDURES (HARDWARE)

1. VX-015DA, VX-030DA, AND VX-050DA DIGITAL POWER AMPLIFIER MODULE

1.1. Changing the Speaker Line Voltage

Though the speaker line voltage of the VX-015DA, VX-030DA, and VX-050DA is factory-preset to 100 V, you can change it to 50 V or 70 V with the output voltage selection switch on the power amplifier's side.

Note

The speaker line failure detection functions are designed to perform on a 100-volt line of speaker. For the methods using a 70- or 50-volt line, please consult your TOA dealer.

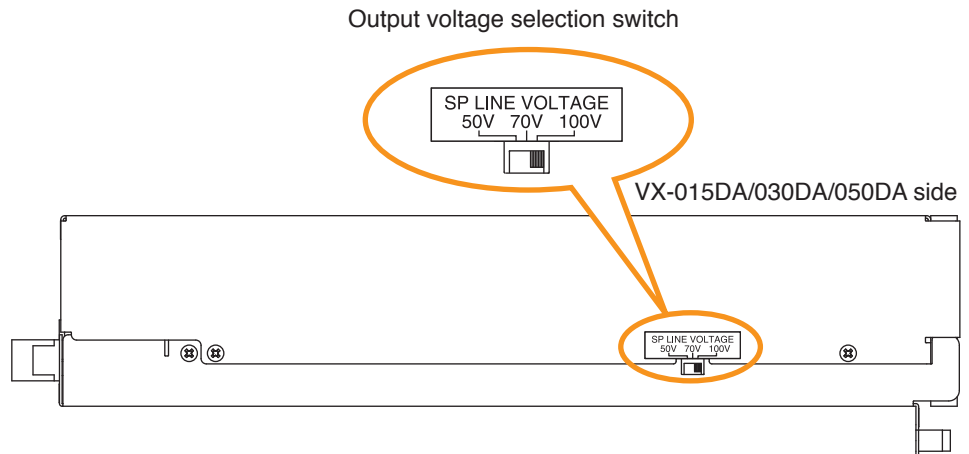

1.2. Replacing the Blade Fuse



WARNING

Be sure to switch off the amplifier's power when replacing the fuse. Inserting or removing the fuse with the amplifier's power on may cause personal injury.

When the blade fuse blew, replace it with new one following the procedures below.

Step : Replace the blade fuse on the rear panel.

Tip

You can replace the fuse with the amplifier module installed in the VX-3000F.

VX-015DA/030DA/050DA rear

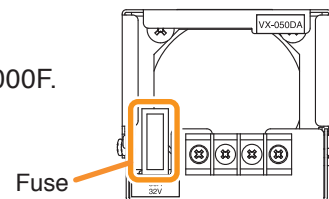

[Capacity]

Model No.	Capacity
VX-015DA	Blade-Type Fuse 10 A
VX-030DA	Blade-Type Fuse 20 A
VX-050DA	Blade-Type Fuse 30 A

2. VX-3004F, VX-3008F, AND VX-3016F VOICE EVACUATION FRAME

2.1. Installing VX-015DA/030DA/050DA Digital Power Amplifier Module

Multiple Digital power amplifier modules can be installed in each VX-3000F unit. The number of the Digital Power Amplifier modules to be installed and their mounting slot ports differ depending on the zone and amplifier module configurations.

[Configuration and mounting slot port in the VX-3004F]

	Without standby amplifier				With standby amplifier			
	1	2	3	4/STANDBY	1	2	3	4/STANDBY
0-Zone	No configuration settable				—	—	—	√
1AB-Zone	√	—	—	—	√	—	—	√
2AB-Zone	√	√	—	—	√	√	—	√
3AB-Zone	√	√	√	—	√	√	√	√
4AB-Zone	√	√	√	√	No configuration settable			

Legend

√ : Installation required
 — : Installation not required

[Configuration and mounting slot port in the VX-3008F]

	Without standby amplifier			With standby amplifier		
	1	2	STANDBY	1	2	STANDBY
8 speaker selectors	—	—	—	No configuration settable		
1 Channel, 8 speaker selectors	√	—	—	√	—	√
2 Channels, 8 speaker selectors	√	√	—	√	√	√

[Configuration and mounting slot port in the VX-3016F]

	Without standby amplifier		With standby amplifier	
	1	2/STANDBY	1	2/STANDBY
16 speaker selectors	—	—	No configuration settable	
1 Channel, 16 speaker selectors	√	—	√	√
2 Channels, 8 speaker selectors	√	√	No configuration settable	

The power amplifier to be installed as a standby amplifier must have the rated power output equal to or larger than the maximum output of the power amplifiers which share the standby amplifier.

[Power amplifier installation procedure]



WARNING

There is a high voltage section inside the power amplifier's filter. Never insert your finger or metallic objects inside the unit. When attaching or detaching the connector, never touch the internal components other than connectors.

Step 1. Shut off the power.
Shut off the power when the power is supplied to the VX-3000F unit.

Step 2. Detach the front panel.
Remove 4 fixing screws for front panel and detach the front panel.

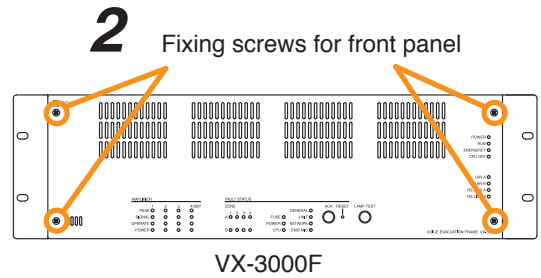

Step 3. Install the digital power amplifier module.
Insert the power amplifier module along the supporting runner until it will not go any further, then secure it using a power amplifier module fixing screw.

Note

Use a #2 bit Philips screwdriver to tighten the fixing screw.

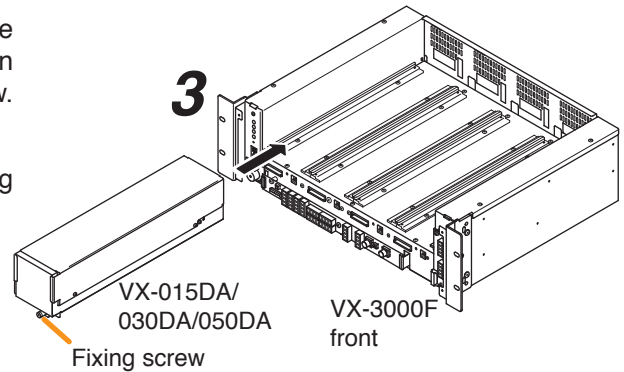

Step 4. Lift the lower portion of the filter, then connect cables.

4-1. Connect both the power amplifier module's DA control link connector and DA output link connector to the VX-3000F's corresponding connectors. Use the cables supplied with the power amplifier module.

Note

After the cable connection is complete, be sure to push the cables against the amplifier side to prevent them from protruding so that the front panel can be easily mounted without obstructing its work.

4-2. Replace the filter.

Step 5. When installing two or more power amplifier modules, repeat **Steps 3** and **4**.

Step 6. Replace the front panel.
Secure it using 4 fixing screws for front panel.

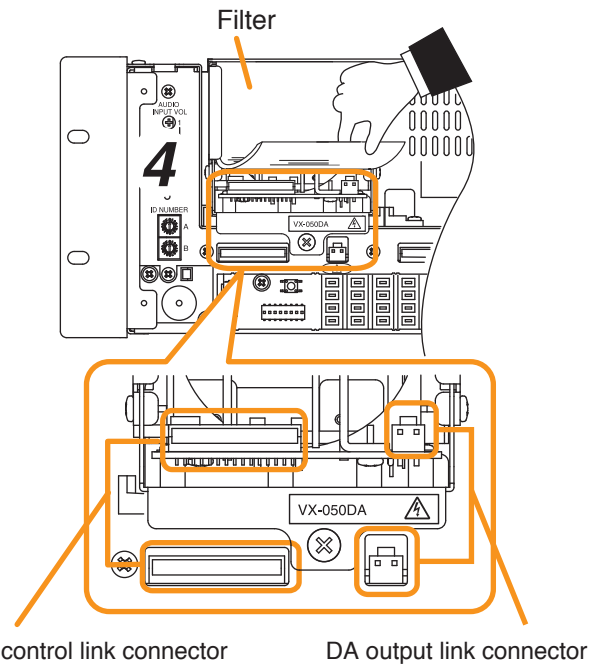

2.2. The Zones Allocation Setting

For the VX-3008F and VX-3016F units, the preset relationship between broadcast zones and power amplifier/line output modules can be changed by the settings of the DIP switch inside the front panel.



VX-3008F: You can perform the zone allocation settings for all-zone emergency broadcast at CPU off state.

Note

For normal broadcasts, use the VX-3000 Setting Software to perform this setting.

VX-3016F: You can perform the zone allocation settings for normal broadcasts, and all-zone emergency broadcast at CPU off state.

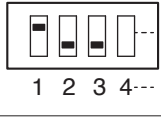
[Modules inside the VX-3008F and output zone configuration]

Switch			Figure	Module and output zone configuration
1	2	3		
OFF	OFF	OFF		Allocates the Slot 1's output to Zones 1 through 8.
ON	OFF	OFF		Allocates the Slot 1's output to Zones 1 through 7 and the Slot 2's output to Zone 8.
OFF	ON	OFF		Allocates the Slot 1's output to Zones 1 through 6 and the Slot 2's output to Zones 7 and 8.
ON	ON	OFF		Allocates the Slot 1's output to Zones 1 through 5 and the Slot 2's output to Zones 6 through 8.
OFF	OFF	ON		Allocates the Slot 1's output to Zones 1 through 4 and the Slot 2's output to Zones 5 through 8.
ON	OFF	ON		Allocates the Slot 1's output to Zones 1 through 3 and the Slot 2's output to Zones 4 through 8.
OFF	ON	ON		Allocates the Slot 1's output to Zones 1 and 2 and the Slot 2's output to Zones 3 through 8.
ON	ON	ON		Allocates the Slot 1's output to Zone 1 and the Slot 2's output to Zones 2 through 8.

[Modules inside the VX-3016F and output zone configuration]

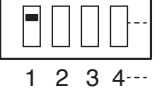
Switch	Figure	Module and output zone configuration
1		
OFF		Allows to allocate the Slot 1's output to Zones 1 through 16 (1 channel, 16 speaker selectors)
ON		Allows to allocate the Slot 1's output to Zones 1 through 8 and the Slot 2's output to Zones 9 through 16. (2 channels, 8 speaker selectors)

[DIP Switch setting]

Step 1. Detach the front panel.
Remove 4 fixing screws for front panel and detach the front panel.

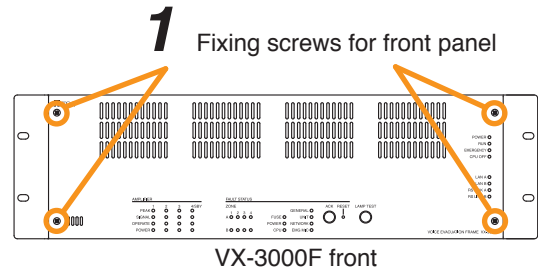

WARNING

There is a high voltage section inside the power amplifier's filter. Never insert your finger or metallic objects inside the unit.

Step 2. Set the DIP switch.
Set the DIP switch so that power amplifier modules and Zone configurations are obtained as intended.

Step 3. Replace the front panel.
Secure it using 4 fixing screws for front panel.

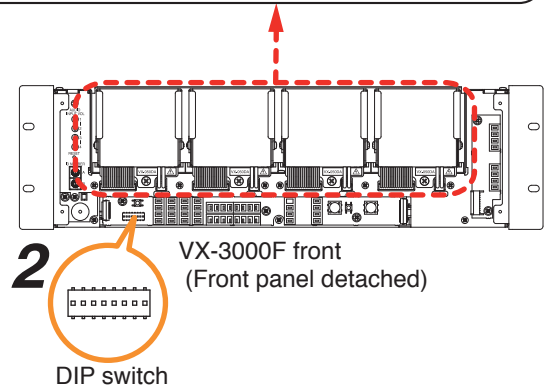

3. VX-300LO LINE OUTPUT MODULE

The VX-3000F is designed to accommodate the VX-300LO Line output modules by the number of the units described below.

- VX-3004F: Up to 4 units
- VX-3008F: Up to 2 units
- VX-3016F: Up to 2 units

[Line output module installation procedure]

Step 1. Shut off the power.
Shut off the power when the power is supplied to the VX-3000F unit.

Step 2. Detach the front panel.
Remove 4 fixing screws for front panel and detach the front panel.

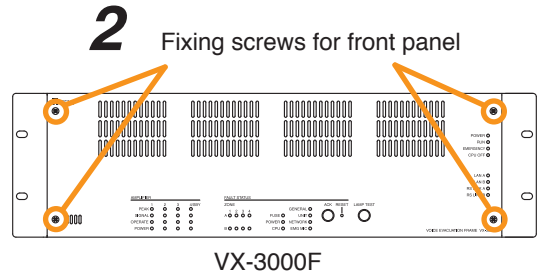

Step 3. Install the line output module.
Insert the line output module along the supporting runner, then secure it using a screw supplied with the module.

Note
Use a #2 bit Philips screwdriver to tighten the fixing screw.

Step 4. Make connection to the DA control link terminal.
Connect to the VX-3000F's DA control link terminal using the cables supplied with the module.

Tip
If you cannot proceed with the procedure in the order from **Steps 4 to 7** depending on the installation situation, do it in the order that suits your convenience.

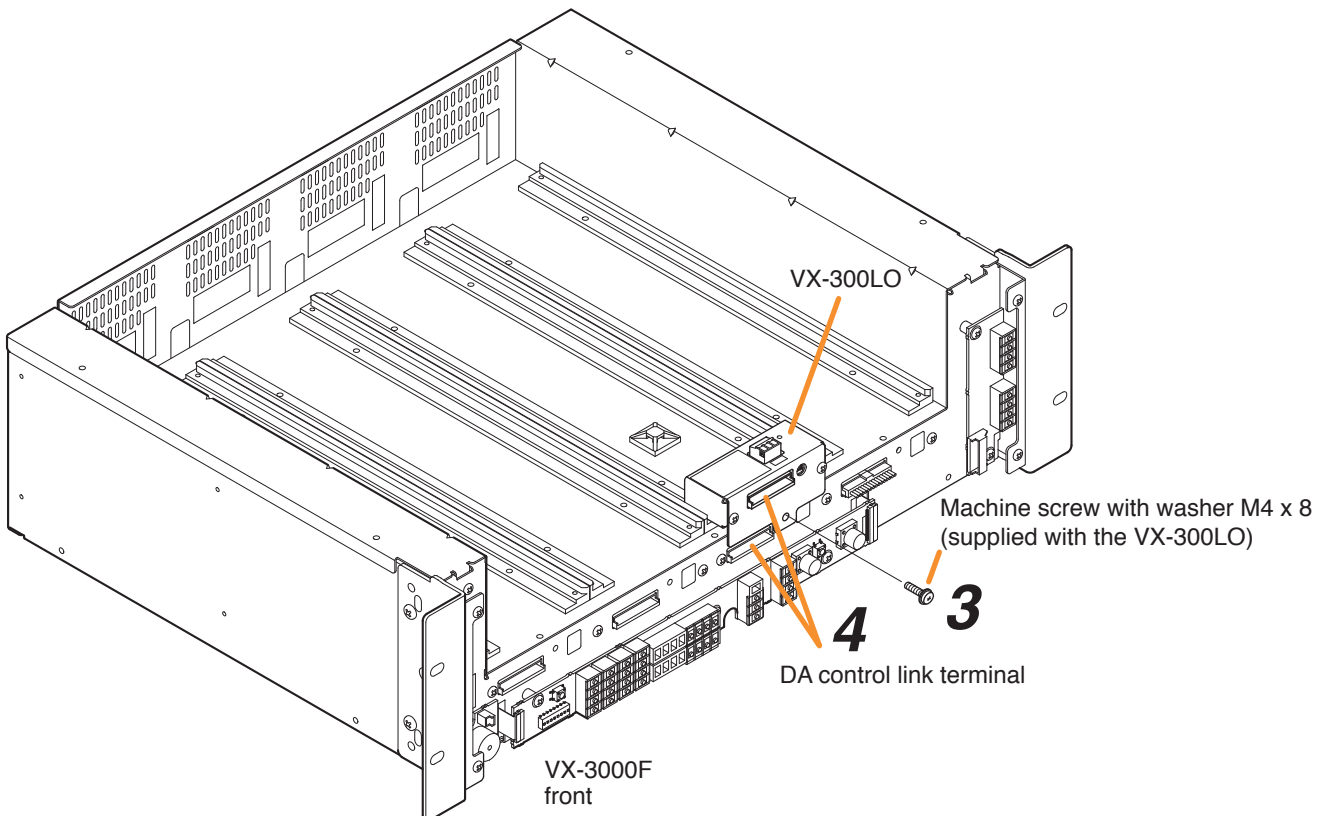

Step 5. Attach each of the mount bases supplied with the Line output module to 2 places. (See the figure below.)

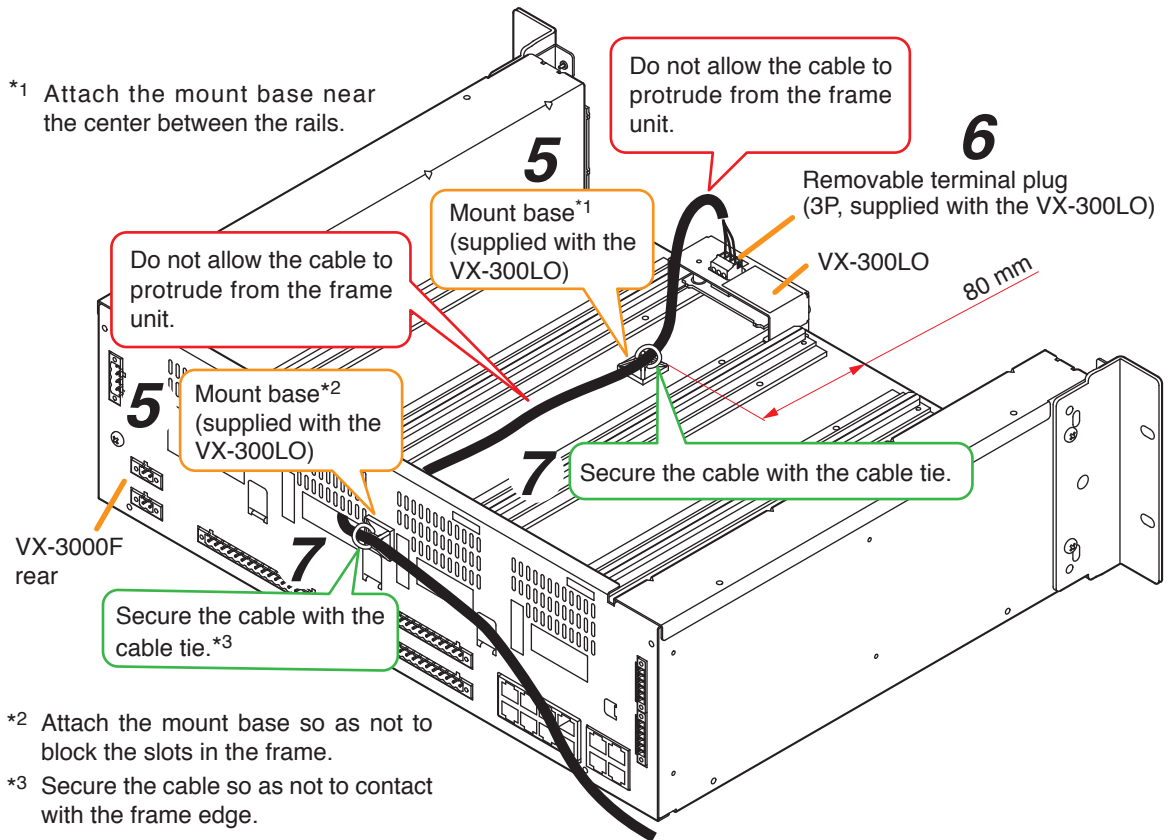

Step 6. Connect the cable to the 3-pin removable terminal plug supplied with Line output module, then attach the terminal plug to the module.
See p. 3-57 for connection of the removable terminal plug.

Step 7. Extract the cable from the cable exit opening in the VX-3000F's rear panel, then secure it to the mount base with the cable tie.

Notes

- Do not allow the cable to protrude outward from the VX-3000F's frame unit and from between the rails on both sides.
- Do not allow the cable pulled out from the opening in the rear panel of the VX-3000F's frame to contact with a sharp edge.

Step 8. Replace the front panel.
Secure it using 4 fixing screws for front panel removed in **Step 2**.

3.1. The ID Number Setting

Notes

- When setting the ID number for multiple VX-3000F units, assign different numbers to each unit. The ID number that can be used must not exceed the actual number of VX-3000F units set using the VX-3000 Setting Software.
- If an ID number is duplicated, then the VX-3000F units assigned that number cannot be controlled by the VX-3000F system.
- The VX-3000F set to ID "0" plays a role of a leader in the whole system, displaying the "GENERAL FAULT" indication and outputting its signal when malfunction occurs within the system.
- In a single VX-3000F configuration, set the ID number to "0."

[ID number setting]

Step 1. Detach the front panel.
Remove 4 fixing screws for front panel and detach the front panel.

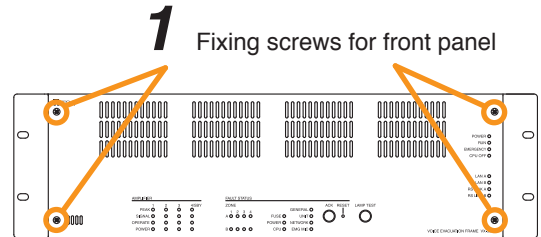

1 Fixing screws for front panel



WARNING

There is a high voltage section inside the power amplifier's filter. Never insert your finger or metallic objects inside the unit.

2 ID Switch

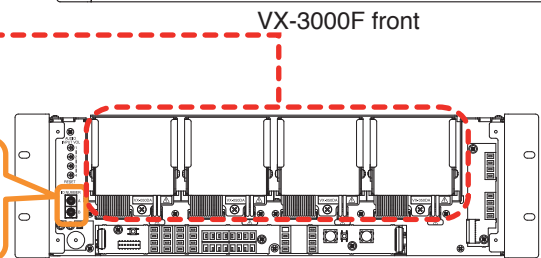

VX-3000F front

VX-3000F front
(Front panel detached)

Step 2. Set the ID switches.

	A	0															
	B	0	1	2	3	4	5	6	7	8	9	A	B	C	D	E	F
ID number		0	1	2	3	4	5	6	7	8	9	10	11	12	13	14	15

	A	1															
	B	0	1	2	3	4	5	6	7	8	9	A	B	C	D	E	F
ID number		16	17	18	19	20	21	22	23	24	25	26	27	28	29	30	31

Note: The ID number is set to No. 0 by default.

Step 3. Replace the front panel.
Secure it using 4 fixing screws for front panel .

3.2. Setting the IP Address

VX-3000F's IP address is automatically determined depending on the ID switch setting as follows when the switch 8 of the DIP switch inside the front panel is set to the ON position (default setting).

IP address : 192.168.14.xx ("xx" is one larger than ID Number.)
 Subnet mask : 255.255.255.0
 Default gateway : 0.0.0.0

To change the above IP address of the VX-3000F, change the DIP switch setting and reactivate the VX-3000F following the procedures below.

Notes

- When the switch 8 is set to the ON position, even if you change and upload the IP address using the VX-3000 Setting software, it will not be changed, remaining as set by default.
- Only the IP address shown above can be set with the Setting switch.
 When wishing to set the IP address other than the above, set it using the VX-3000 Setting Software. (See the separate Setting Software Instructions, "UNIT DETECTION AND NETWORK SETTINGS.")

Step 1. Detach the front panel.
 Remove 4 fixing screws for front panel and detach the front panel.

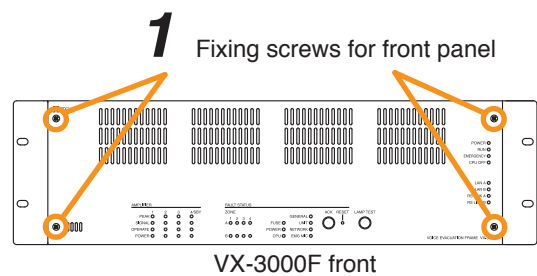

⚠ WARNING

There is a high voltage section inside the power amplifier's filter. Never insert your finger or metallic objects inside the unit.

Step 2. Set the switch 8 of the DIP switch to OFF.

Step 3. Press the reset key.
 The VX-3000F is reactivated.

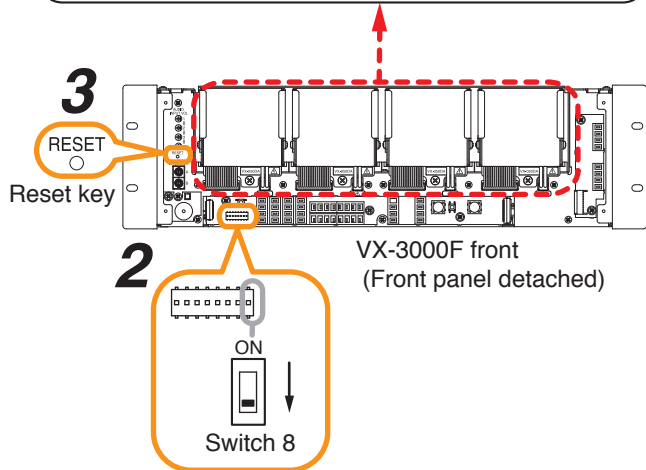



















Step 4. Replace the front panel.
 Secure it using 4 fixing screws for front panel.









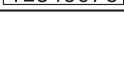















4. VX-3000PM PREAMP MATRIX PANEL





4.1. Setting the IP Address

When Switch 1 of the IP address setting switch inside the front panel is placed in the ON position, the VX-3000PM's IP address will be automatically determined as follows depending on the settings of Switches 2 through 8.

[IP address setting table]

IP address	SW1	SW2	SW3	SW4	SW5	SW6	SW7	SW8	IP address setting switch
192.168.14.51	ON	OFF	OFF	OFF	OFF	OFF	OFF	OFF	ON OFF 
192.168.14.52	ON	OFF	OFF	OFF	OFF	OFF	OFF	ON	ON OFF 
192.168.14.53	ON	OFF	OFF	OFF	OFF	OFF	ON	OFF	ON OFF 
192.168.14.54	ON	OFF	OFF	OFF	OFF	OFF	ON	ON	ON OFF 
192.168.14.55	ON	OFF	OFF	OFF	OFF	ON	OFF	OFF	ON OFF 
192.168.14.56	ON	OFF	OFF	OFF	OFF	ON	OFF	ON	ON OFF 
192.168.14.57	ON	OFF	OFF	OFF	OFF	ON	ON	OFF	ON OFF 
192.168.14.58	ON	OFF	OFF	OFF	OFF	ON	ON	ON	ON OFF 
192.168.14.59	ON	OFF	OFF	OFF	ON	OFF	OFF	OFF	ON OFF 
192.168.14.60	ON	OFF	OFF	OFF	ON	OFF	OFF	ON	ON OFF 
192.168.14.61	ON	OFF	OFF	OFF	ON	OFF	ON	OFF	ON OFF 
192.168.14.62	ON	OFF	OFF	OFF	ON	OFF	ON	ON	ON OFF 
192.168.14.63	ON	OFF	OFF	OFF	ON	ON	OFF	OFF	ON OFF 
192.168.14.64	ON	OFF	OFF	OFF	ON	ON	OFF	ON	ON OFF 
192.168.14.65	ON	OFF	OFF	OFF	ON	ON	ON	OFF	ON OFF 
192.168.14.66	ON	OFF	OFF	OFF	ON	ON	ON	ON	ON OFF 
192.168.14.67	ON	OFF	OFF	ON	OFF	OFF	OFF	OFF	ON OFF 
192.168.14.68	ON	OFF	OFF	ON	OFF	OFF	OFF	ON	ON OFF 
192.168.14.69	ON	OFF	OFF	ON	OFF	OFF	ON	OFF	ON OFF 
192.168.14.70	ON	OFF	OFF	ON	OFF	OFF	ON	ON	ON OFF 
192.168.14.71	ON	OFF	OFF	ON	OFF	ON	OFF	OFF	ON OFF 

IP address	SW1	SW2	SW3	SW4	SW5	SW6	SW7	SW8	IP address setting switch
192.168.14.72	ON	OFF	OFF	ON	OFF	ON	OFF	ON	ON OFF 
192.168.14.73	ON	OFF	OFF	ON	OFF	ON	ON	OFF	ON OFF 
192.168.14.74	ON	OFF	OFF	ON	OFF	ON	ON	ON	ON OFF 
192.168.14.75	ON	OFF	OFF	ON	ON	OFF	OFF	OFF	ON OFF 
192.168.14.76	ON	OFF	OFF	ON	ON	OFF	OFF	ON	ON OFF 
192.168.14.77	ON	OFF	OFF	ON	ON	OFF	ON	OFF	ON OFF 
192.168.14.78	ON	OFF	OFF	ON	ON	OFF	ON	ON	ON OFF 
192.168.14.79	ON	OFF	OFF	ON	ON	ON	OFF	OFF	ON OFF 
192.168.14.80	ON	OFF	OFF	ON	ON	ON	OFF	ON	ON OFF 
192.168.14.81	ON	OFF	OFF	ON	ON	ON	ON	OFF	ON OFF 
192.168.14.82	ON	OFF	OFF	ON	ON	ON	ON	ON	ON OFF 
192.168.14.83	ON	OFF	ON	OFF	OFF	OFF	OFF	OFF	ON OFF 
192.168.14.84	ON	OFF	ON	OFF	OFF	OFF	OFF	ON	ON OFF 
192.168.14.85	ON	OFF	ON	OFF	OFF	OFF	ON	OFF	ON OFF 
192.168.14.86	ON	OFF	ON	OFF	OFF	OFF	ON	ON	ON OFF 
192.168.14.87	ON	OFF	ON	OFF	OFF	ON	OFF	OFF	ON OFF 
192.168.14.88	ON	OFF	ON	OFF	OFF	ON	OFF	ON	ON OFF 
192.168.14.89	ON	OFF	ON	OFF	OFF	ON	ON	OFF	ON OFF 
192.168.14.90	ON	OFF	ON	OFF	OFF	ON	ON	ON	ON OFF 
192.168.14.91	ON	OFF	ON	OFF	ON	OFF	OFF	OFF	ON OFF 
192.168.14.92	ON	OFF	ON	OFF	ON	OFF	OFF	ON	ON OFF 
192.168.14.93	ON	OFF	ON	OFF	ON	OFF	ON	OFF	ON OFF 
192.168.14.94	ON	OFF	ON	OFF	ON	OFF	ON	ON	ON OFF 
192.168.14.95	ON	OFF	ON	OFF	ON	ON	OFF	OFF	ON OFF 
192.168.14.96	ON	OFF	ON	OFF	ON	ON	OFF	ON	ON OFF 

IP address	SW1	SW2	SW3	SW4	SW5	SW6	SW7	SW8	IP address setting switch
192.168.14.97	ON	OFF	ON	OFF	ON	ON	ON	OFF	ON OFF 
192.168.14.98	ON	OFF	ON	OFF	ON	ON	ON	ON	ON OFF 
192.168.14.99	ON	OFF	ON	ON	OFF	OFF	OFF	OFF	ON OFF 
192.168.14.100	ON	OFF	ON	ON	OFF	OFF	OFF	ON	ON OFF 

[IP address setting]

To set the VX-3000PM's IP address, change the IP address setting switch configuration with the following procedures.

Notes

- Placing Switch 1 in the OFF position disables the settings performed using Switches 2 through 8. In this case, the IP address uploaded by the VX-3000 Setting Software becomes valid.
- The IP address setting switch allows the IP address to be set only in the range of "192.168.14.51" to "192.168.14.100". If you wish to set IP address out of this range, set it using the VX-3000 Setting Software. (See the separate Setting Software Instructions, "UNIT DETECTION AND NETWORK SETTINGS.")

Step 1. Detach the front panel.

Loosen 2 front panel fixing screws to detach the front panel.

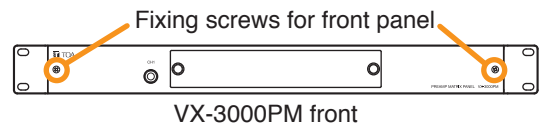

Step 2. Place Switch 1 of the IP address setting switch in the ON position, then Switches 2 through 8 in the positions corresponding to the desired IP address.

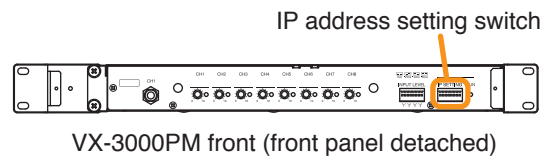

Step 3. Replace the front panel.

Secure it using 2 fixing screws for front panel.

Step 4. (Only when the IP address has been reset after power-on) Reactivate the VX-3000PM.





















Stop supplying the power to the VX-3000PM, then supply the power again. Otherwise, reactivate the unit using the VX-3000 Setting Software. (See the separate Setting Software Instructions, "Restarting VX-3000 Unit.")









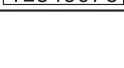















5. VX-3000CT CONTROL PANEL

























5.1. Setting the IP Address



















When Switch 1 of the IP address setting switch inside the front panel is placed in the ON position, the VX-3000CT's IP address will be automatically determined as follows depending on the settings of Switches 2 through 8.

[IP address setting table]

IP address	SW1	SW2	SW3	SW4	SW5	SW6	SW7	SW8	IP address setting switch
192.168.14.111	ON	OFF	OFF	OFF	OFF	OFF	OFF	OFF	ON OFF 
192.168.14.112	ON	OFF	OFF	OFF	OFF	OFF	OFF	ON	ON OFF 
192.168.14.113	ON	OFF	OFF	OFF	OFF	OFF	ON	OFF	ON OFF 
192.168.14.114	ON	OFF	OFF	OFF	OFF	OFF	ON	ON	ON OFF 
192.168.14.115	ON	OFF	OFF	OFF	OFF	ON	OFF	OFF	ON OFF 
192.168.14.116	ON	OFF	OFF	OFF	OFF	ON	OFF	ON	ON OFF 
192.168.14.117	ON	OFF	OFF	OFF	OFF	ON	ON	OFF	ON OFF 
192.168.14.118	ON	OFF	OFF	OFF	OFF	ON	ON	ON	ON OFF 
192.168.14.119	ON	OFF	OFF	OFF	ON	OFF	OFF	OFF	ON OFF 
192.168.14.120	ON	OFF	OFF	OFF	ON	OFF	OFF	ON	ON OFF 
192.168.14.121	ON	OFF	OFF	OFF	ON	OFF	ON	OFF	ON OFF 
192.168.14.122	ON	OFF	OFF	OFF	ON	OFF	ON	ON	ON OFF 
192.168.14.123	ON	OFF	OFF	OFF	ON	ON	OFF	OFF	ON OFF 
192.168.14.124	ON	OFF	OFF	OFF	ON	ON	OFF	ON	ON OFF 
192.168.14.125	ON	OFF	OFF	OFF	ON	ON	ON	OFF	ON OFF 
192.168.14.126	ON	OFF	OFF	OFF	ON	ON	ON	ON	ON OFF 
192.168.14.127	ON	OFF	OFF	ON	OFF	OFF	OFF	OFF	ON OFF 
192.168.14.128	ON	OFF	OFF	ON	OFF	OFF	OFF	ON	ON OFF 
192.168.14.129	ON	OFF	OFF	ON	OFF	OFF	ON	OFF	ON OFF 
192.168.14.130	ON	OFF	OFF	ON	OFF	OFF	ON	ON	ON OFF 
192.168.14.131	ON	OFF	OFF	ON	OFF	ON	OFF	OFF	ON OFF 

IP address	SW1	SW2	SW3	SW4	SW5	SW6	SW7	SW8	IP address setting switch
192.168.14.132	ON	OFF	OFF	ON	OFF	ON	OFF	ON	ON OFF 
192.168.14.133	ON	OFF	OFF	ON	OFF	ON	ON	OFF	ON OFF 
192.168.14.134	ON	OFF	OFF	ON	OFF	ON	ON	ON	ON OFF 
192.168.14.135	ON	OFF	OFF	ON	ON	OFF	OFF	OFF	ON OFF 
192.168.14.136	ON	OFF	OFF	ON	ON	OFF	OFF	ON	ON OFF 
192.168.14.137	ON	OFF	OFF	ON	ON	OFF	ON	OFF	ON OFF 
192.168.14.138	ON	OFF	OFF	ON	ON	OFF	ON	ON	ON OFF 
192.168.14.139	ON	OFF	OFF	ON	ON	ON	OFF	OFF	ON OFF 
192.168.14.140	ON	OFF	OFF	ON	ON	ON	OFF	ON	ON OFF 
192.168.14.141	ON	OFF	OFF	ON	ON	ON	ON	OFF	ON OFF 
192.168.14.142	ON	OFF	OFF	ON	ON	ON	ON	ON	ON OFF 
192.168.14.143	ON	OFF	ON	OFF	OFF	OFF	OFF	OFF	ON OFF 
192.168.14.144	ON	OFF	ON	OFF	OFF	OFF	OFF	ON	ON OFF 
192.168.14.145	ON	OFF	ON	OFF	OFF	OFF	ON	OFF	ON OFF 
192.168.14.146	ON	OFF	ON	OFF	OFF	OFF	ON	ON	ON OFF 
192.168.14.147	ON	OFF	ON	OFF	OFF	ON	OFF	OFF	ON OFF 
192.168.14.148	ON	OFF	ON	OFF	OFF	ON	OFF	ON	ON OFF 
192.168.14.149	ON	OFF	ON	OFF	OFF	ON	ON	OFF	ON OFF 
192.168.14.150	ON	OFF	ON	OFF	OFF	ON	ON	ON	ON OFF 
192.168.14.151	ON	OFF	ON	OFF	ON	OFF	OFF	OFF	ON OFF 
192.168.14.152	ON	OFF	ON	OFF	ON	OFF	OFF	ON	ON OFF 
192.168.14.153	ON	OFF	ON	OFF	ON	OFF	ON	OFF	ON OFF 
192.168.14.154	ON	OFF	ON	OFF	ON	OFF	ON	ON	ON OFF 
192.168.14.155	ON	OFF	ON	OFF	ON	ON	OFF	OFF	ON OFF 
192.168.14.156	ON	OFF	ON	OFF	ON	ON	OFF	ON	ON OFF 

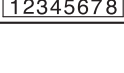
IP address	SW1	SW2	SW3	SW4	SW5	SW6	SW7	SW8	IP address setting switch
192.168.14.157	ON	OFF	ON	OFF	ON	ON	ON	OFF	ON OFF 
192.168.14.158	ON	OFF	ON	OFF	ON	ON	ON	ON	ON OFF 
192.168.14.159	ON	OFF	ON	ON	OFF	OFF	OFF	OFF	ON OFF 
192.168.14.160	ON	OFF	ON	ON	OFF	OFF	OFF	ON	ON OFF 
192.168.14.161	ON	OFF	ON	ON	OFF	OFF	ON	OFF	ON OFF 
192.168.14.162	ON	OFF	ON	ON	OFF	OFF	ON	ON	ON OFF 
192.168.14.163	ON	OFF	ON	ON	OFF	ON	OFF	OFF	ON OFF 
192.168.14.164	ON	OFF	ON	ON	OFF	ON	OFF	ON	ON OFF 
192.168.14.165	ON	OFF	ON	ON	OFF	ON	ON	OFF	ON OFF 
192.168.14.166	ON	OFF	ON	ON	OFF	ON	ON	ON	ON OFF 
192.168.14.167	ON	OFF	ON	ON	ON	OFF	OFF	OFF	ON OFF 
192.168.14.168	ON	OFF	ON	ON	ON	OFF	OFF	ON	ON OFF 
192.168.14.169	ON	OFF	ON	ON	ON	OFF	ON	OFF	ON OFF 
192.168.14.170	ON	OFF	ON	ON	ON	OFF	ON	ON	ON OFF 
192.168.14.171	ON	OFF	ON	ON	ON	ON	OFF	OFF	ON OFF 
192.168.14.172	ON	OFF	ON	ON	ON	ON	OFF	ON	ON OFF 
192.168.14.173	ON	OFF	ON	ON	ON	ON	ON	OFF	ON OFF 
192.168.14.174	ON	OFF	ON	ON	ON	ON	ON	ON	ON OFF 
192.168.14.175	ON	ON	OFF	OFF	OFF	OFF	OFF	OFF	ON OFF 
192.168.14.176	ON	ON	OFF	OFF	OFF	OFF	OFF	ON	ON OFF 
192.168.14.177	ON	ON	OFF	OFF	OFF	OFF	ON	OFF	ON OFF 
192.168.14.178	ON	ON	OFF	OFF	OFF	OFF	ON	ON	ON OFF 
192.168.14.179	ON	ON	OFF	OFF	OFF	ON	OFF	OFF	ON OFF 
192.168.14.180	ON	ON	OFF	OFF	OFF	ON	OFF	ON	ON OFF 
192.168.14.181	ON	ON	OFF	OFF	OFF	ON	ON	OFF	ON OFF 

IP address	SW1	SW2	SW3	SW4	SW5	SW6	SW7	SW8	IP address setting switch
192.168.14.182	ON	ON	OFF	OFF	OFF	ON	ON	ON	ON OFF 
192.168.14.183	ON	ON	OFF	OFF	ON	OFF	OFF	OFF	ON OFF 
192.168.14.184	ON	ON	OFF	OFF	ON	OFF	OFF	ON	ON OFF 
192.168.14.185	ON	ON	OFF	OFF	ON	OFF	ON	OFF	ON OFF 
192.168.14.186	ON	ON	OFF	OFF	ON	OFF	ON	ON	ON OFF 
192.168.14.187	ON	ON	OFF	OFF	ON	ON	OFF	OFF	ON OFF 
192.168.14.188	ON	ON	OFF	OFF	ON	ON	OFF	ON	ON OFF 
192.168.14.189	ON	ON	OFF	OFF	ON	ON	ON	OFF	ON OFF 
192.168.14.190	ON	ON	OFF	OFF	ON	ON	ON	ON	ON OFF 
192.168.14.191	ON	ON	OFF	ON	OFF	OFF	OFF	OFF	ON OFF 
192.168.14.192	ON	ON	OFF	ON	OFF	OFF	OFF	ON	ON OFF 
192.168.14.193	ON	ON	OFF	ON	OFF	OFF	ON	OFF	ON OFF 
192.168.14.194	ON	ON	OFF	ON	OFF	OFF	ON	ON	ON OFF 
192.168.14.195	ON	ON	OFF	ON	OFF	ON	OFF	OFF	ON OFF 
192.168.14.196	ON	ON	OFF	ON	OFF	ON	OFF	ON	ON OFF 
192.168.14.197	ON	ON	OFF	ON	OFF	ON	ON	OFF	ON OFF 
192.168.14.198	ON	ON	OFF	ON	OFF	ON	ON	ON	ON OFF 
192.168.14.199	ON	ON	OFF	ON	ON	OFF	OFF	OFF	ON OFF 
192.168.14.200	ON	ON	OFF	ON	ON	OFF	OFF	ON	ON OFF 

[IP address setting]

To set the VX-3000CT's IP address, change the IP address setting switch configuration with the following procedures.

Notes

- Placing Switch 1 in the OFF position disables the settings performed using Switches 2 through 8. In this case, the IP address uploaded by the VX-3000 Setting Software becomes valid.
- The IP address setting switch allows the IP address to be set only in the range of "192.168.14.111" to "192.168.14.200". If you wish to set IP address out of this range, set it using the VX-3000 Setting Software. (See the separate Setting Software Instructions, "UNIT DETECTION AND NETWORK SETTINGS.")

Step 1. Place Switch 1 of the IP address setting switch in the ON position, then Switches 2 through 8 in the positions corresponding to the desired IP address.

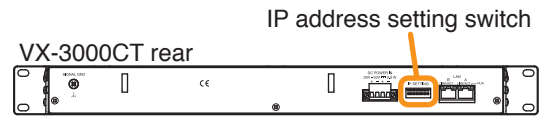

Step 2. (Only when the IP address has been reset after power-on) Reactivate the VX-3000PM. Press the VX-3000CT's Reset key to restart.

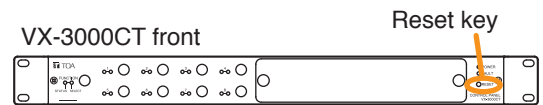

6. RM-200SF, RM-300X, AND RM-500 MICROPHONES

6.1. The ID Number Settings (RM-200F and RM-300X: Switches 1 – 3 operation or RM-500: Switches 2 – 4 operation)

For the RM-200SF and the RM-300X, use Switches 1 to 3 of the DIP switch, and for the RM-500, use Switches 2 to 4* of the DIP switch to set the ID number (device number).

The DIP switch is located on the unit's rear panel for the RM-200SF, and on the side panel for the RM-300X, and on the bottom panel for the RM-500.

* ID number setting switches of the RM-500 are assigned to Switches 1 through 4. Always, leave the Switch 1 "OFF" (factory default).

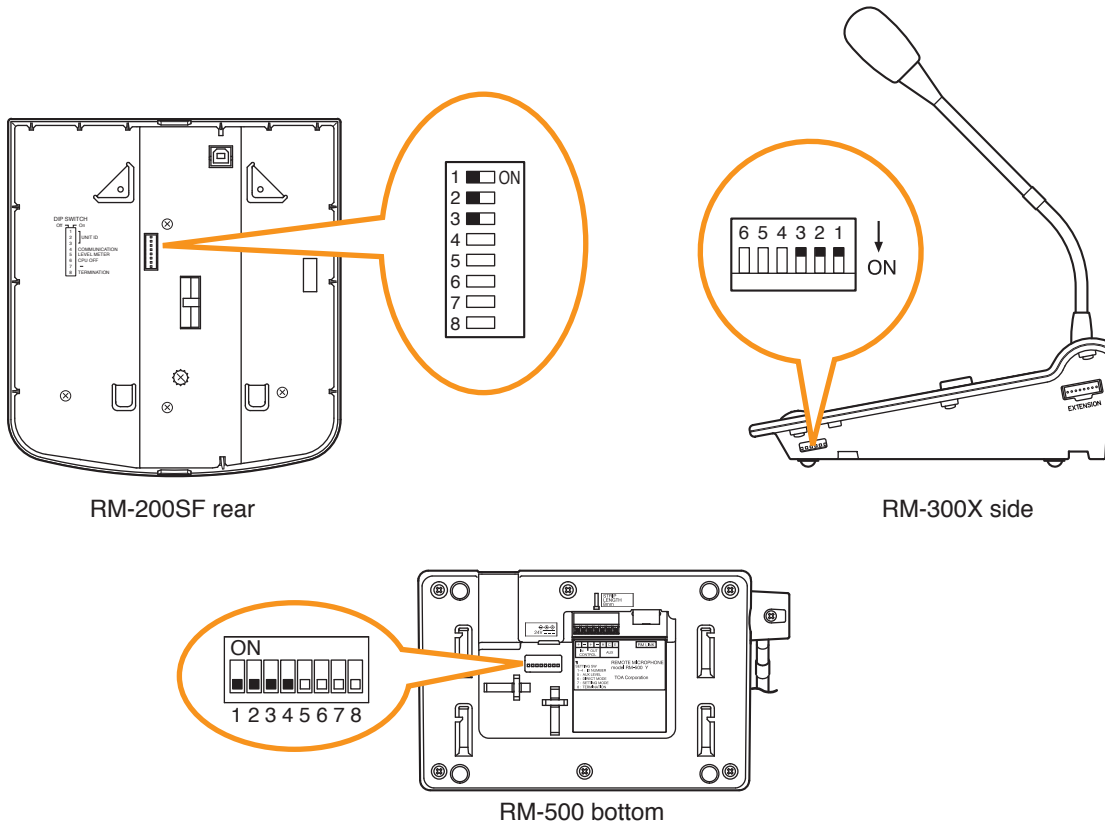





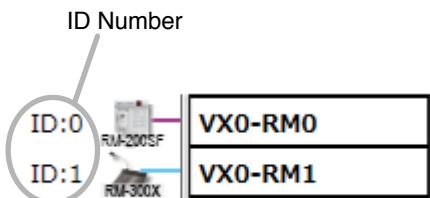

- A total of up to 8 RM-200SF, RM-300X, and RM-500 microphones can be connected per system. If the system is required to comply with EN54-16, only a total of up to 2 RM-200SF and/or RM-300X units of the 8 are allowed for connection. (See p. 3-59.)
- An ID Number must be set for each connected Remote microphone. The ID Number must be identical to that which is set by the PC software. On the PC screen, the ID Number appears at the left of the Remote microphone symbol.

[Remote microphone on the PC screen]

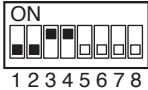

- The ID Number is factory-preset to "0."

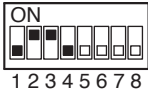
Device number	Switch 3	Switch 2	Switch 1	RM-200SF	RM-300X
0 (Default setting)	OFF	OFF	OFF		
1	OFF	OFF	ON		
2	OFF	ON	OFF		
3	OFF	ON	ON		
4	ON	OFF	OFF		
5	ON	OFF	ON		
6	ON	ON	OFF		
7	ON	ON	ON		

Device number	Switch 1	Switch 2	Switch 3	Switch 4	RM-500
0 (Default setting)	OFF	OFF	OFF	OFF	
1	OFF	OFF	OFF	ON	
2	OFF	OFF	ON	OFF	
3	OFF	OFF	ON	ON	
4	OFF	ON	OFF	OFF	
5	OFF	ON	OFF	ON	
6	OFF	ON	ON	OFF	
7	OFF	ON	ON	ON	

6.2. Adjusting Microphone Sensitivity

6.2.1. RM-200SF: Switch 5 operation or RM-300X: Switch 4 operation)

Since the DIP switch can be set to make the broadcast status indicator show output signal level,* adjust the microphone sensitivity using the following procedure:

* When the microphone is in use, the indicator shows the output signal level. When the microphone is not in use, it shows the broadcast status.

Step 1. Set switch 5 of the DIP switch on the rear panel of the RM-200SF to ON or switch 4 on the side panel of the RM-300X to ON.

The broadcast status indicator on front panel of the RM-200SF or top panel of the RM-300X switches to show the output signal level.

Note

Both switches are set to OFF by default.

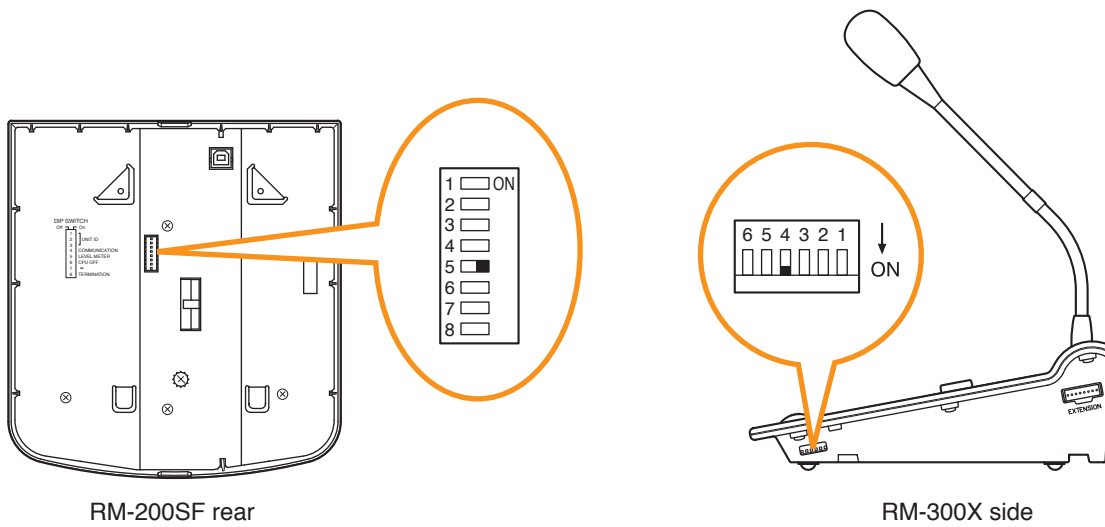

Step 2. Speak into the microphone.

The broadcast status indicator shows the microphone's output signal level. The following table shows how the output level is shown.

Indicator Color	Output Signal Level
Lights red	Over 0 dB
Lights green	-20 dB to 0 dB — Appropriate level
Off	Under -20 dB

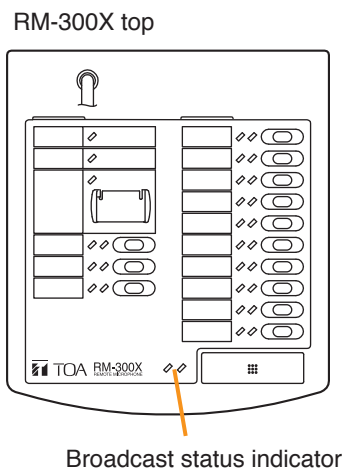
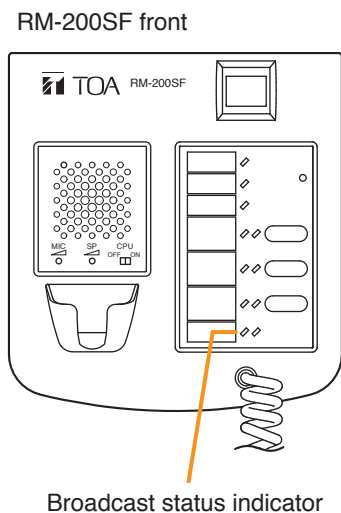

Step 3. Using the microphone volume control, adjust the microphone input sensitivity to an appropriate level (until the broadcast status indicator lights green).

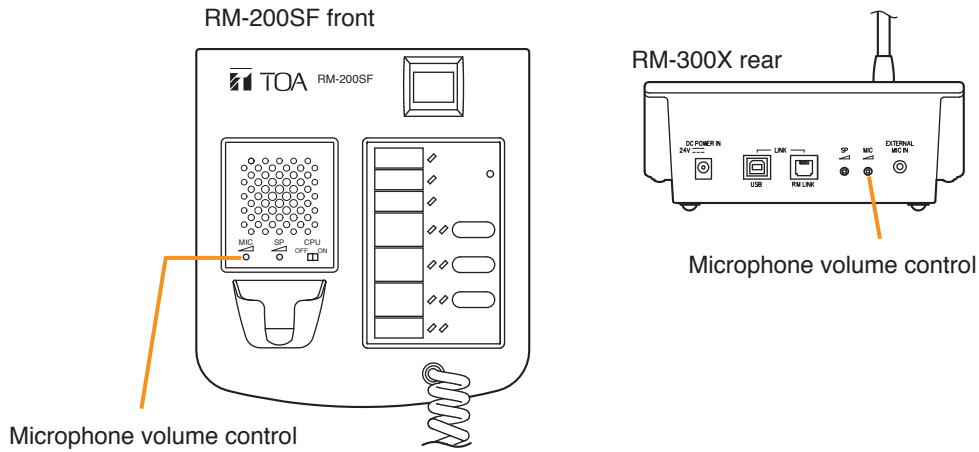

Step 4. Set switch 5 of the RM-200SF to OFF or switch 4 of the RM-300X to OFF.

Note

Be sure to set both switches to OFF after adjusting the microphone input sensitivity.

6.3. Setting The RM-500's Menu

The settings related to the remote controller are performed with the VX-3000 Setting software. While for the RM-500, only the own unit's operation settings can be changed from the menu on the RM-500's LCD screen. The menu also includes the items to perform the level meter display and the restart of the RM-500.

6.3.1. Menu configuration

Setting item	Setting contents	Option	Default
1 Operation setting			
1-1 LCD setting			
1-1-1 Contrast setting*	Sets the contrast of the RM-500's LCD screen.	1 – 9	4
1-1-2 Brightness setting	Sets the brightness of the RM-500's LCD screen.	1 – 6	3
1-2 Advanced setting		ON, OFF	OFF
1-2-1 Display mic. level	When this function is set to ON, the microphone volume level meter is displayed while the chime icon is not displayed in the Chime display area of the LCD screen.	ON, OFF	OFF
1-2-2 Speech intelligibly	Selects whether or not to make the speech intelligible by the signal processing function. (See "Setting of speech intelligibly" on p. 3-28.)	ON, OFF	OFF
1-2-3 AUX mic. setting	This function disables the RM-500's microphone and allows the microphone connected to the AUX input terminal to be controlled by the RM-500's Talk key.	Use, Not use	Not use
1-2-4 TALK timeout extension	This function allows you to add 30 seconds to the Talk key timeout set with the VX-3000 Setting software.	No extension, +30 seconds	No extension
2 Maintenance/Volume setting			
2-1 Level meter	Displays the level in 14 steps according to the input level of the microphone and the AUX. (See "Adjusting input sensitivity" on p. 3-27.)	–	–
2-2 Status	Displays the system name (when the VX-3000 system is connected: VX-3000) for the connection target, and the ID number and firmware version of the remote microphone being operated.		
2-3 RM-500 reset	Restarts the RM-500.	–	–
3 Exit	–	–	–

* The larger the brightness setting value, the more visible the LCD screen even in dark places, making the life of the backlight shorter.

6.3.2. Entering the menu screen

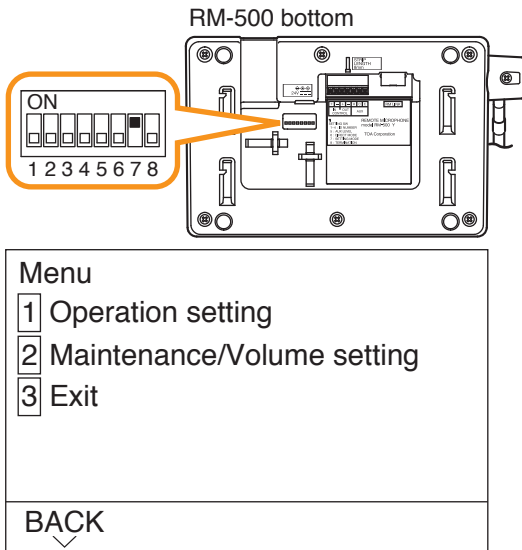

Step: Set Switch 7 of the setting switch on the RM-500's bottom panel to the ON position.

Notes

- Do not touch the setting switch while broadcast is in progress using this unit.
The screen will not move to the menu screen even if you operate the setting switch during broadcast.
- Broadcast cannot be made from this unit while the menu screen is displayed.

A menu is displayed on the RM-500's LCD screen.

6.3.3. Keys used on the menu screen

The keys described below are used on the Menu screen.

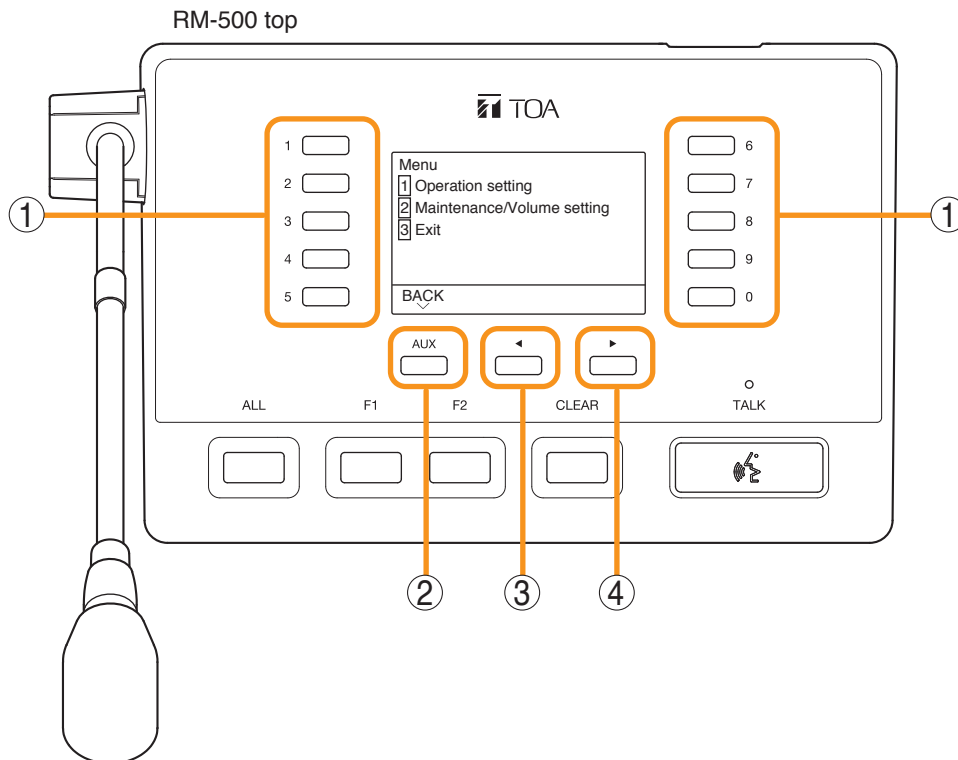

1. Numeric keys

Used to enter the numbers of selection items or options.

2. AUX key

Allows operation according to the display when pressed while a guide indication is present at the lower left on the menu screen.

3. ◀ key

Allows operation according to the display when pressed while a guide indication is present at the lower center on the menu screen.

4. ▶ key

Allows operation according to the display when pressed while a guide indication is present at the lower right on the menu screen.

6.3.4. Basic operation on the menu screen

- On the Menu item selection screen, operate as described below.

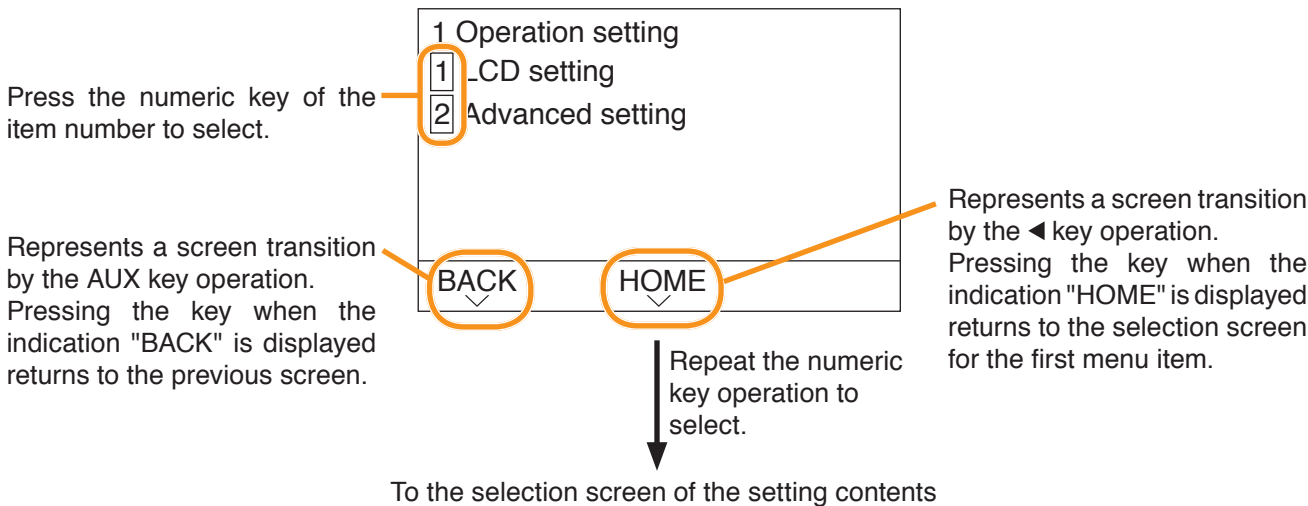

- On the Setting contents selection screen, operate as described below.

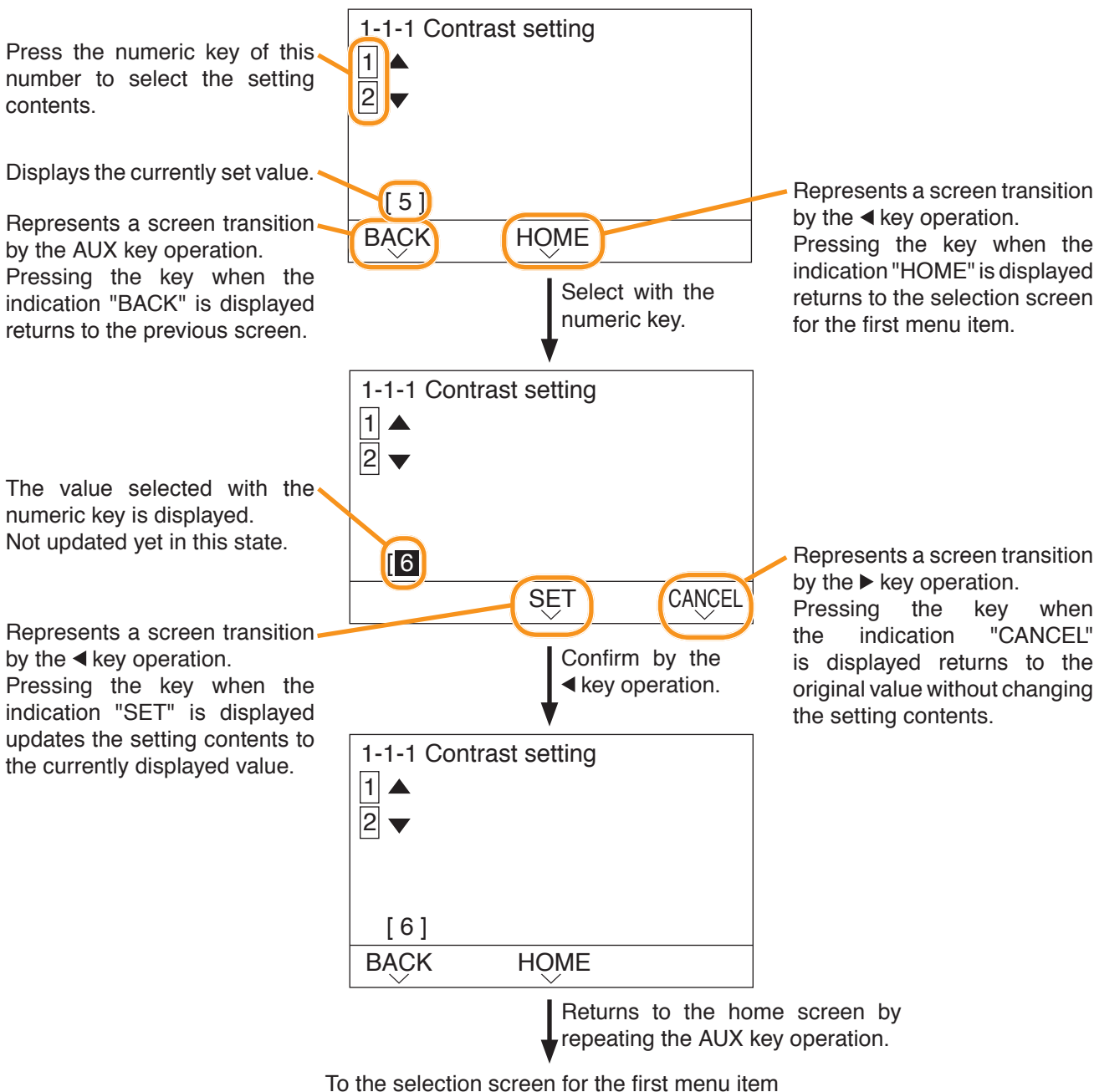

6.3.5. Adjusting input sensitivity

Adjust the microphone input sensitivity of the RM-500 confirming the peak level on the LCD screen.

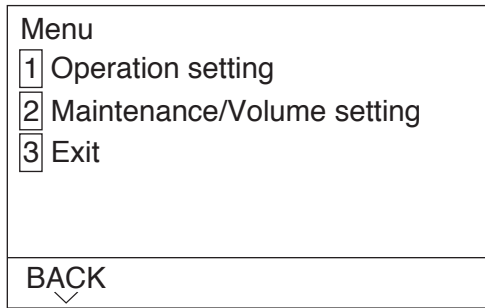

Step 1. Press the [2] key on the menu screen.

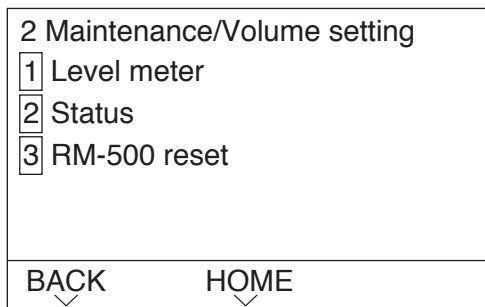

The Maintenance item selection screen is displayed.

Step 2. Press the [1] key.

(When AUX mic. setting is set to "Not use")

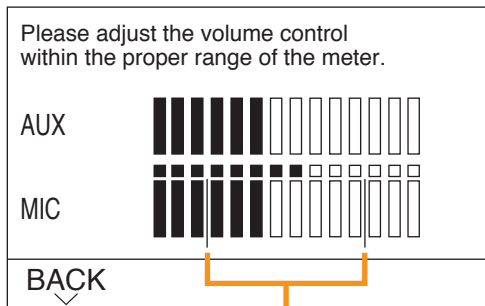

The input levels of the microphone input and the AUX input are displayed in 14 steps.

The upper meter of the microphone volume shows the peak level, and the lower meter the current level.

Appropriate level range

(When AUX mic. setting is set to "Use")

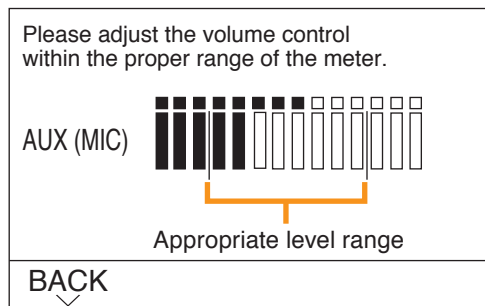

Tip

When the AUX microphone setting is set to "Use," only the input level of the microphone connected to the AUX input terminal is displayed.

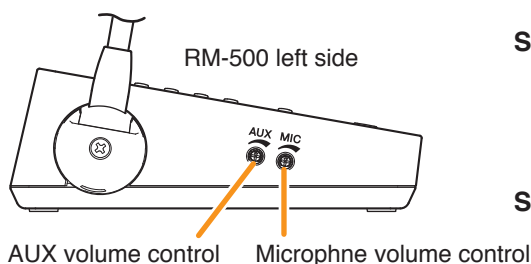

Step 3. Speak into the microphone.

Step 4. Adjust the microphone input sensitivity with the microphone volume control or AUX volume control so that it is kept in the appropriate level range.

6.3.6. Setting of speech intelligibly

Turning on the speech intelligibility function makes it easier to hear the microphone announcements even in a noisy environment* and also allows the microphone to pick up the audio signals at an appropriate level even if speaking too close to or too far from it.

* Depends on the surrounding environment. The effectiveness is not guaranteed as there are individual differences in hearing sensitivity.

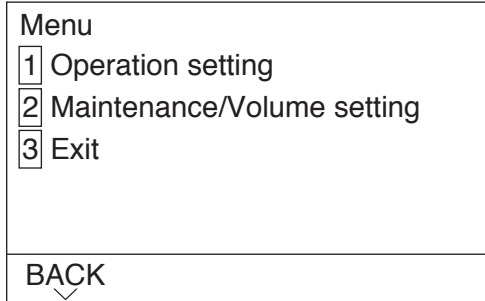

Step 1. Press the [1] key on the menu screen.

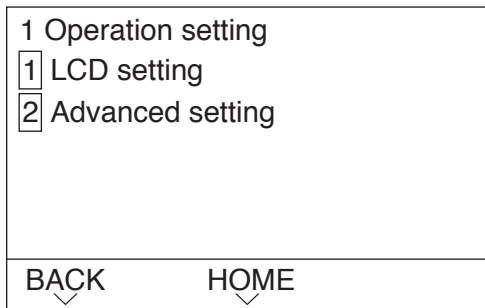

The Operation setting item selection screen is displayed.

Step 2. Press the [2] key.

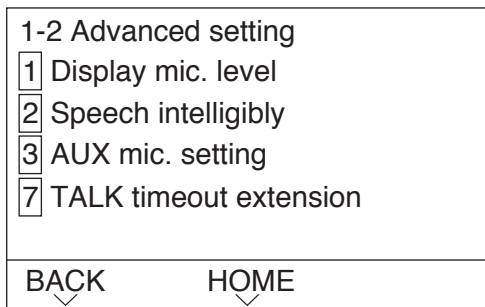

The Advanced setting item selection screen is displayed.

Step 3. Press the [2] key.

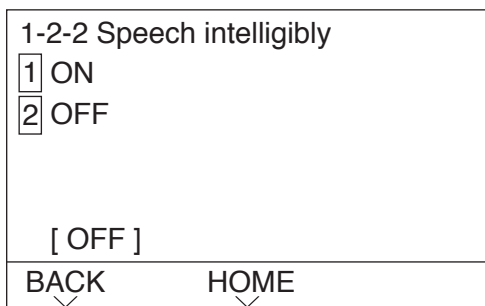

The Speech intelligibly setting screen is displayed.

Step 4. Press the [1] key.

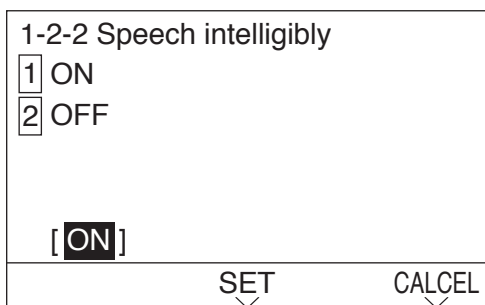

"ON" is selected.

Step 5. Press the ◀ key.
The set contents are confirmed.

Note

In a high noise environment or in places where feedback is likely to occur, do not use this function.

6.3.7. Exit the menu and return to the normal screen

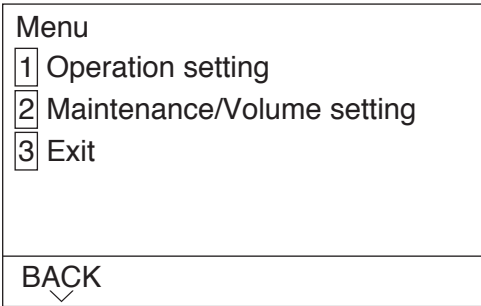

Step 1. When you have finished operation in the menu, press the ◀ key to select "HOME" to return to the selection screen for the first menu item.

Tip

This operation can also be done by pressing the AUX key several times.

Step 2. Press the [3] key and select "Exit menu."

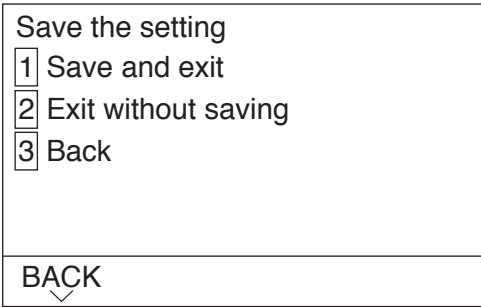

The setting save confirmation screen is displayed.

Step 3. Press the [1] key.

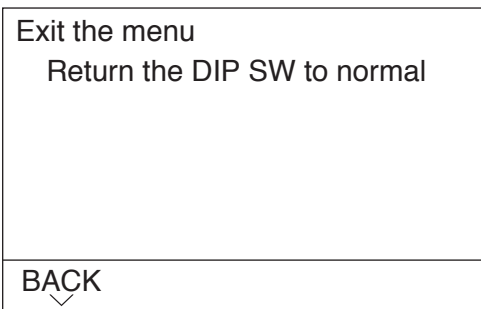

The setting change completion screen is displayed.

RM-500 bottom

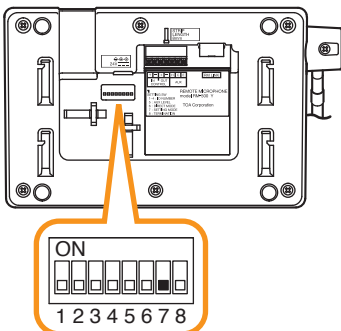

Step 4. Set Switch 7 of the setting switch on the RM-500's bottom panel to the OFF position. The screen returns to the normal screen.

6.4. CPU Off Function (All-Zone Emergency Broadcast) Settings (RM-200SF: Switch 6 operation or RM-300X: Switch 5 operation)

The CPU off function permits the all-zone calls to be made from the RM-200SF or RM-300X by bypassing the CPU* normally used by the VX-3000F and using an analog link instead. This function is usually used if a system failure is preventing normal broadcasts from being made. Announcement from the RM-200SF can be made to all zones within the system only while the Talk Switch is being pressed with the CPU switch on its front panel set to OFF, or announcement from the RM-300X can be made to the said zones while its All-Zone Emergency Broadcast key is being held down for 4 seconds or more. Whether or not this function is available can be set using switch 6 of the DIP switch on the rear panel of the RM-200SF or switch 5 on the side panel of the RM-300X. (Regarding how to make such broadcasts, see the separate Operating Instructions, "OPERATION.")

* CPU is a central processing unit, which is built in the VX-3000F.

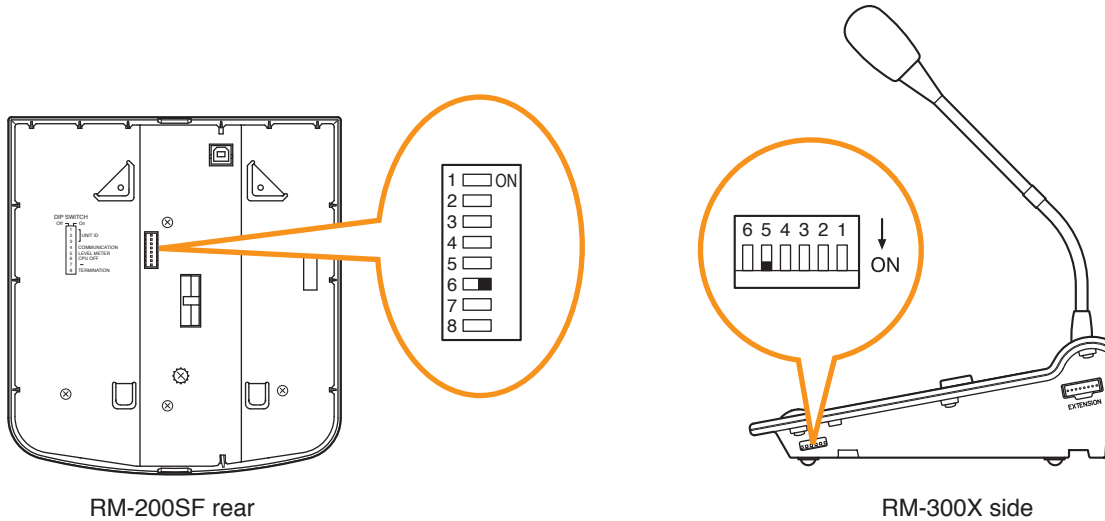

Note

Set the CPU off function to "Disabled" as in the table below for systems that do not use the analog link.

CPU off function (Emergency all-call)	Switch	RM-200SF	RM-300X
Enabled	ON (Default position)		
Disabled	OFF		

6.5. Termination Setting (RM-200SF, RM-500: Switch 8 operation)

Set the termination of the RM communication line. Normally set to OFF.

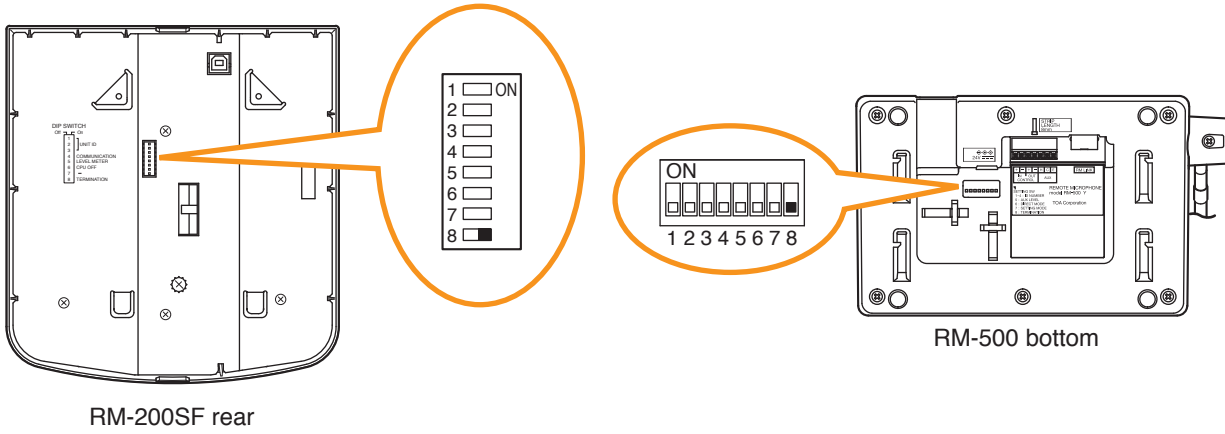

Terminal function	Switch	RM-200SF	RM-500
OFF	OFF		
ON	ON (Default position)		

6.6. Using an External Microphone (RM-300X Only)



WARNING

This change should only be performed by a qualified professional electrician. If users open the unit case or modify the unit, this may cause fire or electric shock.

Changing the jumper settings on the RM-300X's circuit board causes an external microphone to be used.

Notes

- Turn off the power before starting this work.
- To avoid damage from static electricity, never touch the parts on the circuit board.
- An external microphone input and an auxiliary input (see p. 3-34) cannot be used at the same time.

Step 1. Unscrew 8 screws indicated by arrows in the figure at right, then detach the RM-300X's upper case.

Note

Note the types of screws.

- A: 3 x 8 tapping screw (white silver) 6 pieces
 B: 3 x 10 tapping screw (black) 2 pieces

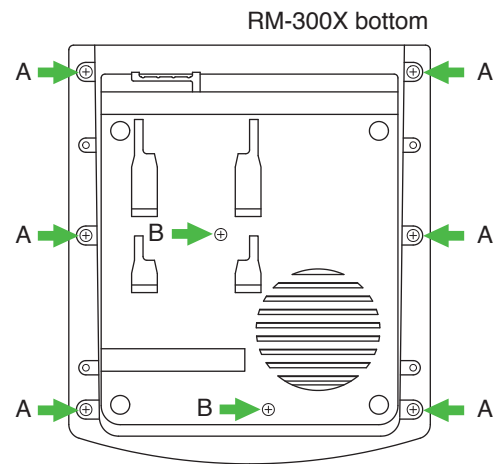

Step 2. Set the jumper's position (SW301 and SW302) on the circuit board attached to the bottom plate as shown below.

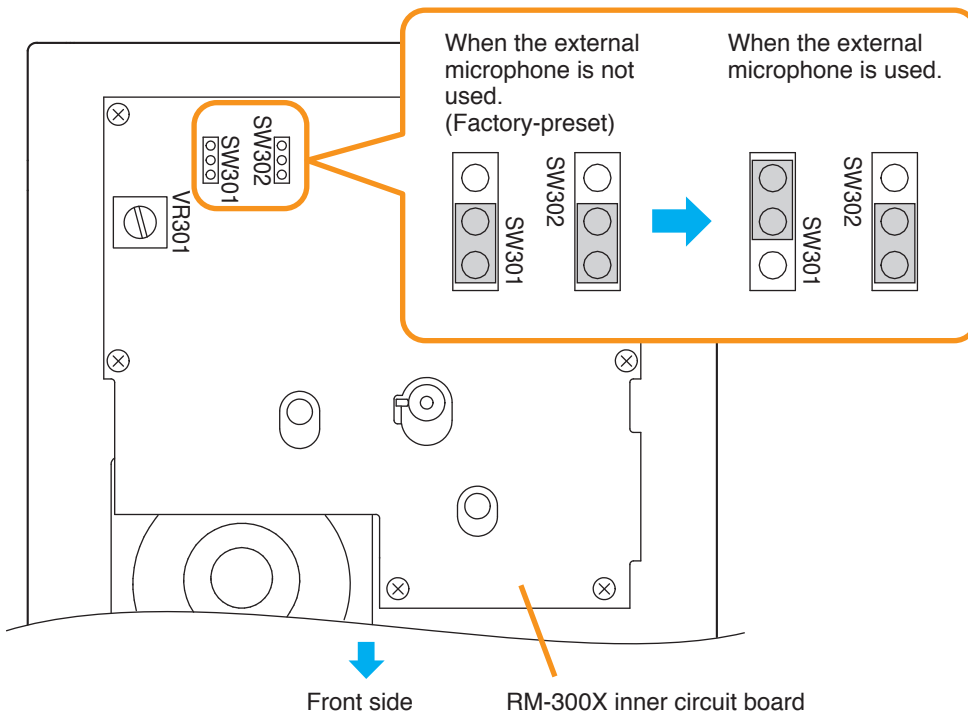

Step 3. Replace the RM-300X's upper case.

Note

Note the types of screws when replacing the upper case (See **Step 1.**)

[Plug for connection to the RM-300X's external input terminal]

Connect the microphone's signal line to the tip and its shield line to the sleeve of the stereo mini plug or monaural mini plug.

Tip

The WH-4000A, YP-M101, or YP-M301 can be used for the external microphone.

[Stereo mini plug]

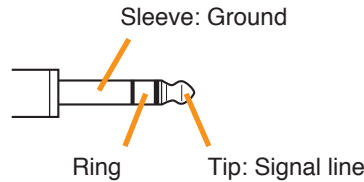

[Monaural mini plug]

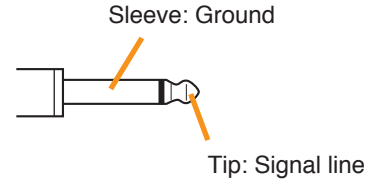

6.7. Setting the Level of the AUX Input Terminal (RM-500 Only)

When using the RM-500's AUX input terminal, set the input level with Switch 5 of the setting switch depending on the connected device.

Shift Switch 5 to Line level (OFF position) when connecting the external sound source device or to MIC level (ON position) when connecting the external microphone.

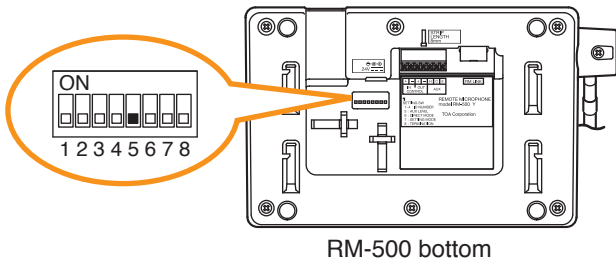

RM-500 bottom

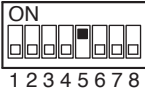
Input sensitivity	Switch	RM-500
Line level -20 dB* 10 kΩ Unbalanced	OFF (Default position)	
Microphone level -60 dB* 2.2 kΩ Unbalanced	ON	

* 0 dB = 1V

6.8. Setting for using the direct selection mode (RM-500 Only)

The RM-500 has a direct selection function that allows you to specify the line number by directly entering it when selecting the broadcast zone.

To use the direct selection mode, you need to change the setting of the switch 6 of the setting switch.

For the operation using the direct selection mode, refer to the separate Operating Instructions, "Making Microphone Announcements in Direct Selection Mode."

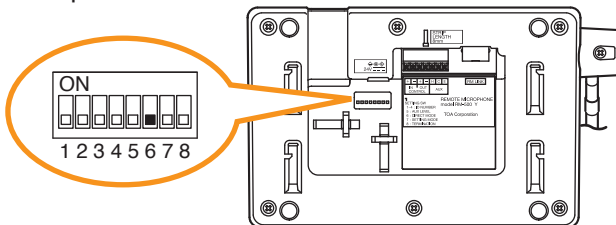

RM-500 bottom

Note

Do not touch the setting switch while broadcast is in progress using this unit.

The screen will not be switched even if you operate the setting switch during broadcast.

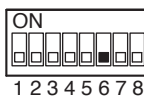
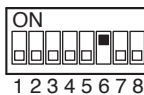
Direct selection function	Switch	RM-500
Not use (The normal screen is displayed on the RM-500's LCD screen.)		OFF (Default position)
Use (The line number registration screen is displayed on the RM-500's LCD screen.)		ON

6.9. Using an Auxiliary Input (RM-300X Only)



WARNING This change should only be performed by a qualified professional electrician. If users open the unit case or modify the unit, this may cause fire or electric shock.

Changing the jumper settings on the RM-300X's circuit board causes an auxiliary input to be used. Adjust the sound volume of the AUX input with the VR301 on the pc board.

Notes

- Turn off the power before starting this work.
- To avoid damage from static electricity, never touch the parts on the circuit board.
- An external microphone input (see p. 3-32) and an auxiliary input cannot be used at the same time.

Step 1. Unscrew 8 screws indicated by arrows in the figure at right, then detach the RM-300X's upper case.

Note

Note the types of screws.

- A: 3 x 8 tapping screw (white silver) 6 pieces
- B: 3 x 10 tapping screw (black) 2 pieces

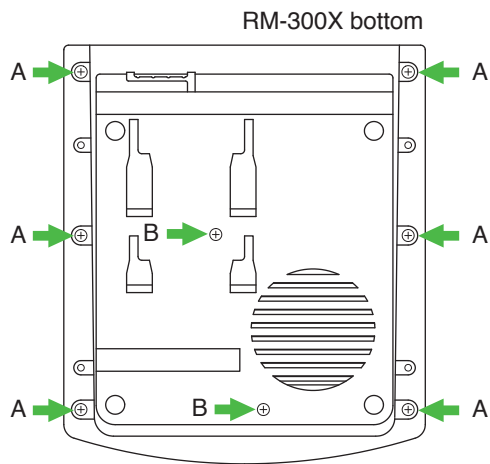

Step 2. Set the jumper's position (SW301 and SW302) on the circuit board attached to the bottom plate as shown below.

AUX input volume control

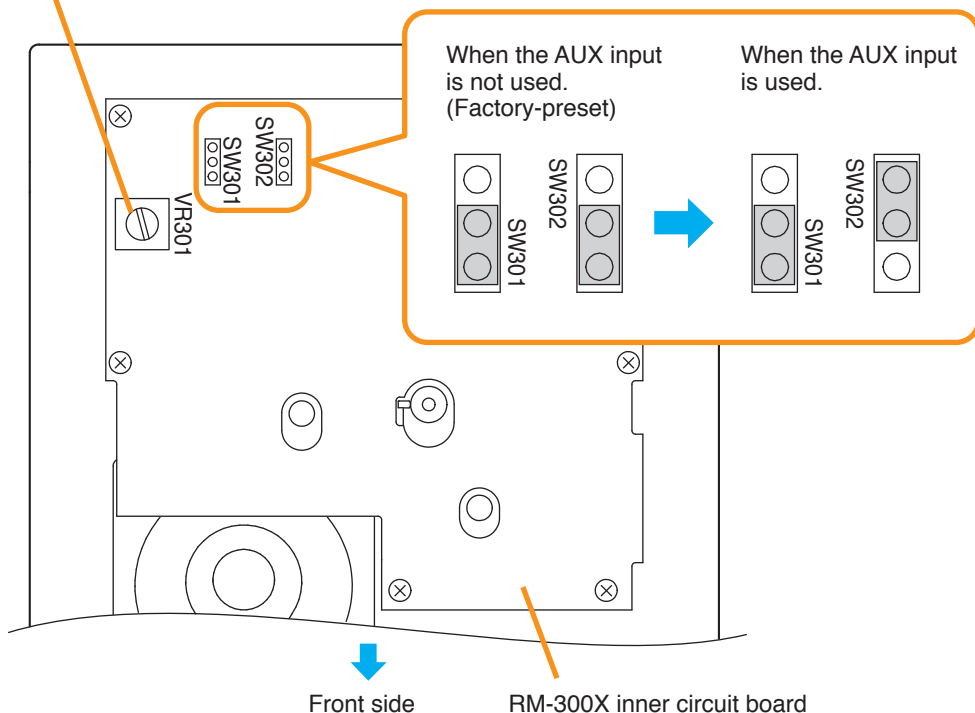

Step 3. Replace the RM-300X's upper case.

Note

Note the types of screws when replacing the upper case (See **Step 1.**)

[Plug for connection to the RM-300X's external input terminal]

Connect the sound source's signal line to the ring and its shield line to the sleeve of the stereo mini plug.

[Stereo mini plug]

Sleeve: Ground



Ring: Signal line

Tip

6.10. Compressor Function Setting (RM-200SF and RM-300X only)



WARNING

This change should only be performed by a qualified professional electrician. If users open the unit case or modify the unit, this may cause fire or electric shock.

The compressor function enables even large signals to be broadcast without distortion. (This function is factory-preset to ON.)

Notes

- Turn off the power before starting this work.
- To avoid damage from static electricity, never touch the parts on the circuit board.

[RM-200SF]

Step 1. Unscrew 5 screws in the figure at right, then detach the RM -200SF's rear plate.

Note

Note the specific shapes of the different screws.

Inch screw (combination drive) No.6-32 x 1/4 (1)
Tooth lock washer (1)

RM-200SF rear

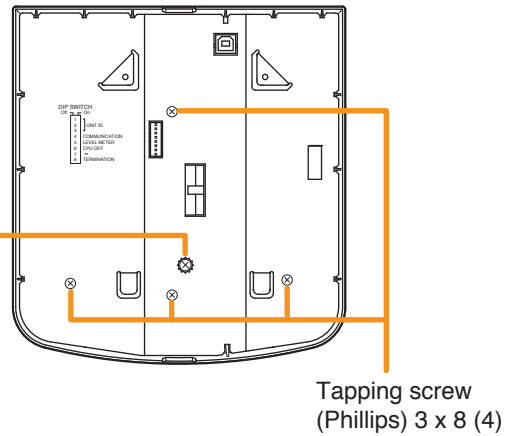

Step 2. Set the jumper's position (JP301) on the circuit board attached to the front case as shown below.

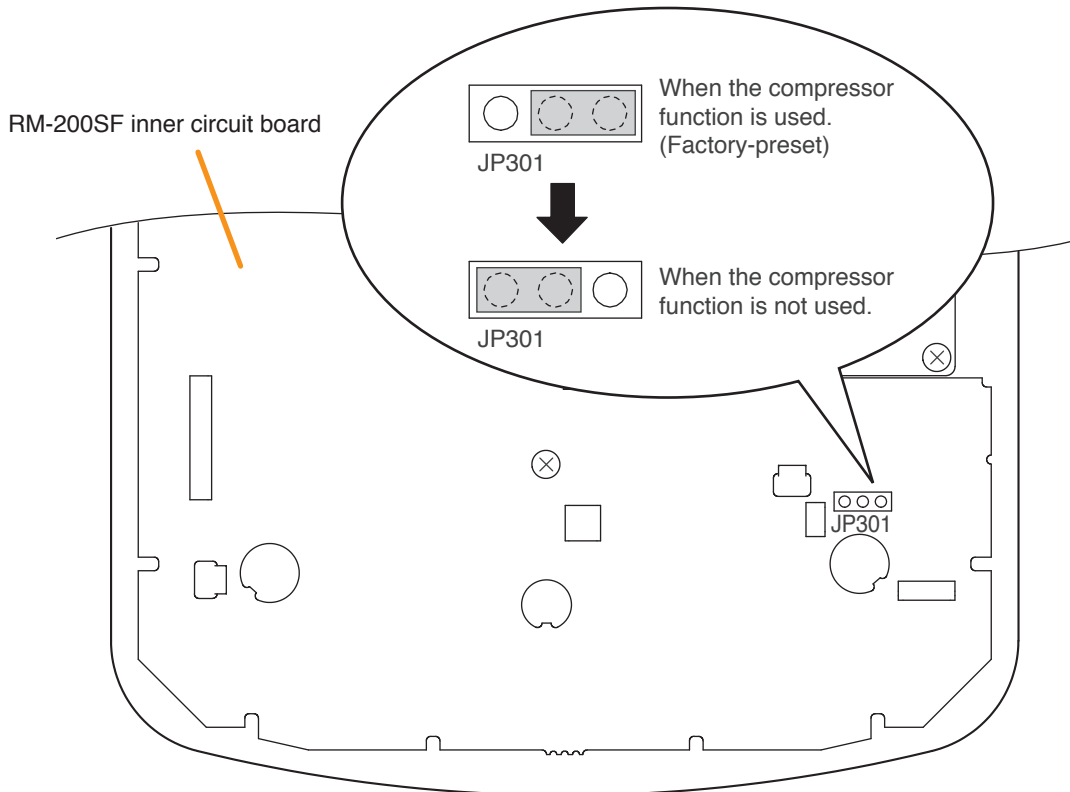

Step 3. Replace the RM-200SF's rear plate.

Note: Note the specific shapes of the different screws when replacing the rear plate. (See Step 1.)

[RM-300X]

Step 1. Unscrew 8 screws indicated by arrows in the figure at right, then detach the RM-300X's upper case.

Note

Note the types of screws.

A: 3 x 8 tapping screw (white silver) 6 pieces

B: 3 x 10 tapping screw (black) 2 pieces

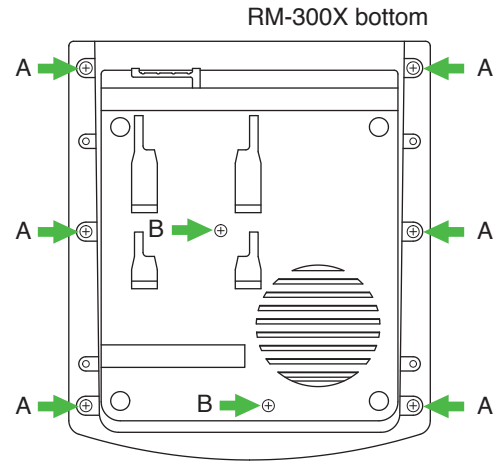

Step 2. Set the jumper's position (SW304) on the circuit board attached to the bottom plate as shown below.

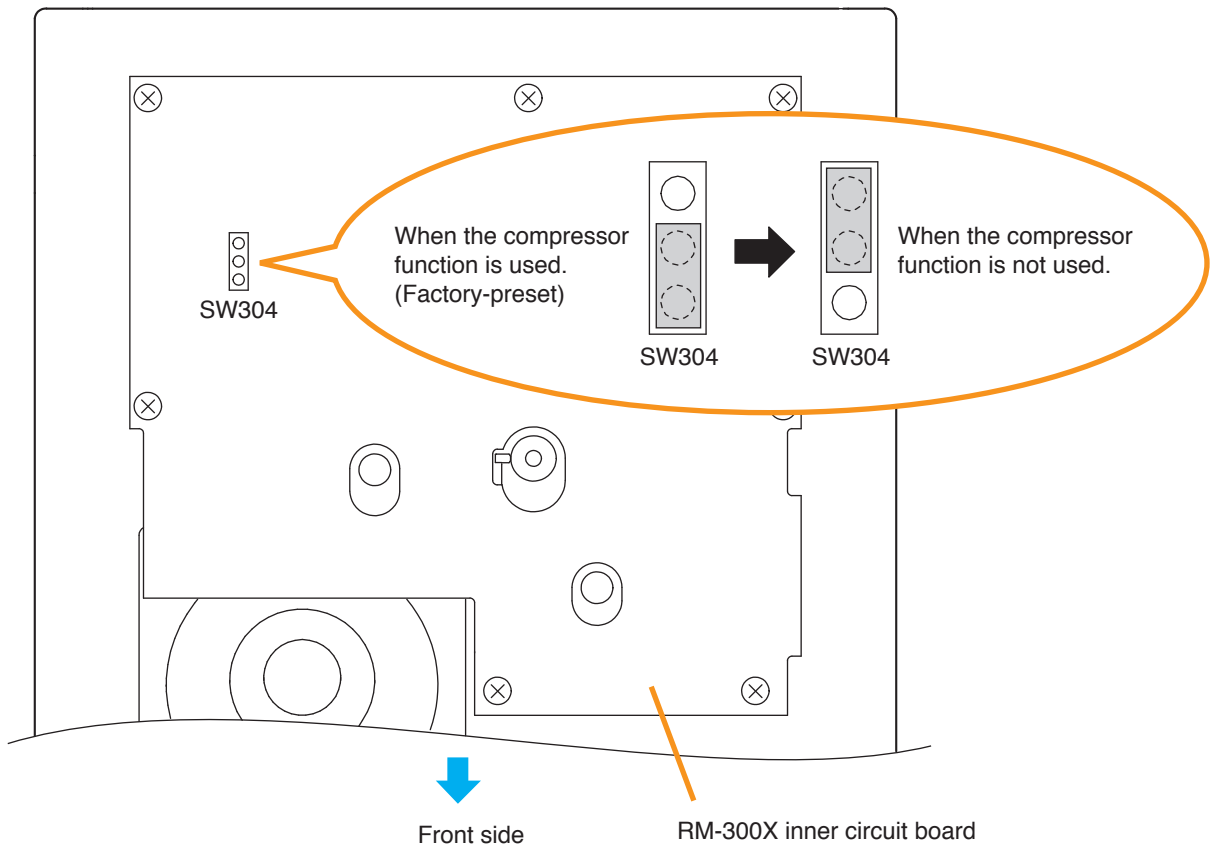

Step 3. Replace the RM-300X's upper case.

Note: Note the types of screws when replacing the upper case (See **Step 1.**)

6.11. Microphone Fault Detection Function Setting (RM-300X Only)



WARNING

This work should only be performed by a qualified professional electrician. If users open the unit case or modify the unit, this may cause fire or electric shock.

The RM-300X is equipped with the microphone fault detection function, which can be set to OFF . (Factory-preset to ON)

Notes

- Turn off the power before starting this work.
- To avoid damage from static electricity, never touch the parts on the circuit board.

Step 1. Unscrew 8 screws indicated by arrows in the figure at right, then detach the RM-300X's upper case.

Note

Note the types of screws.

- A: 3 x 8 tapping screw (white silver) 6 pieces
 B: 3 x 10 tapping screw (black) 2 pieces

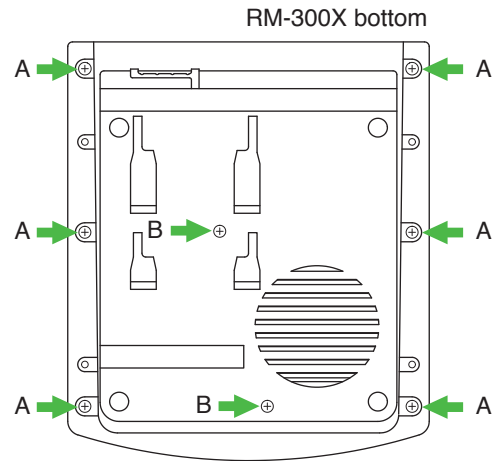

Step 2. Set the jumper's position (SW303) on the circuit board attached to the bottom plate as shown below.

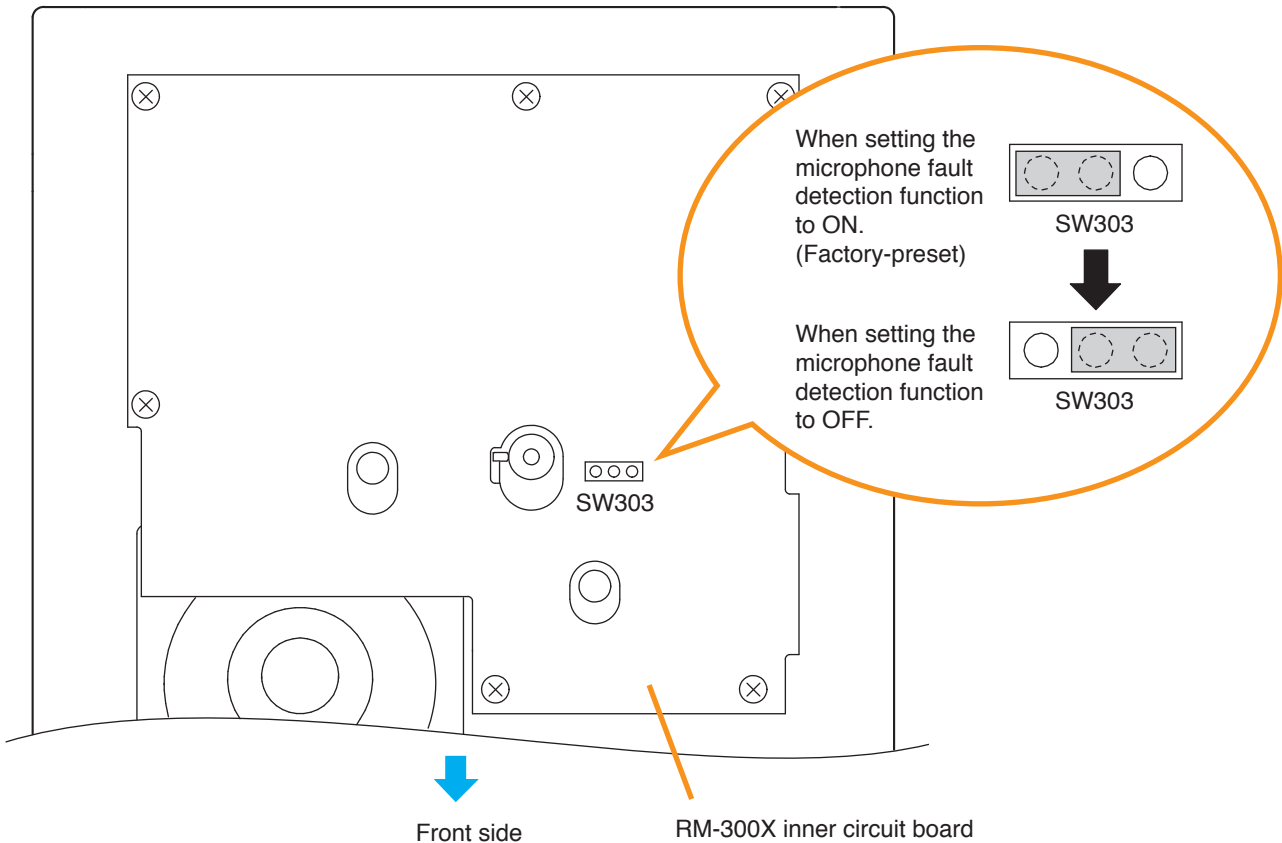

Step 3. Replace the RM-300X's upper case.

Note: Note the types of screws when replacing the upper case (See **Step 1.**)

6.12. Installing the RM-200SF on a Wall

The RM-200SF is designed for on-wall installation.

[Mounting hardware]

To mount the RM-200SF on the wall, the following parts are required.

Wall mount bracket unit	1	(supplied with the RM-200SF)
Wall mounting screws		
4 x 25 tapping screw for wooden wall	2	(supplied with the RM-200SF)
M3.5 x 20 screw for electrical box	2	(supplied with the RM-200SF)

[Ferrite cable clamp attachment]

The supplied ferrite clamp needs to be attached to the Link cable as illustrated below.

As its mounting timing differs depending on the installation way of the RM-200SF, mount the clamp in the appropriate installation step.

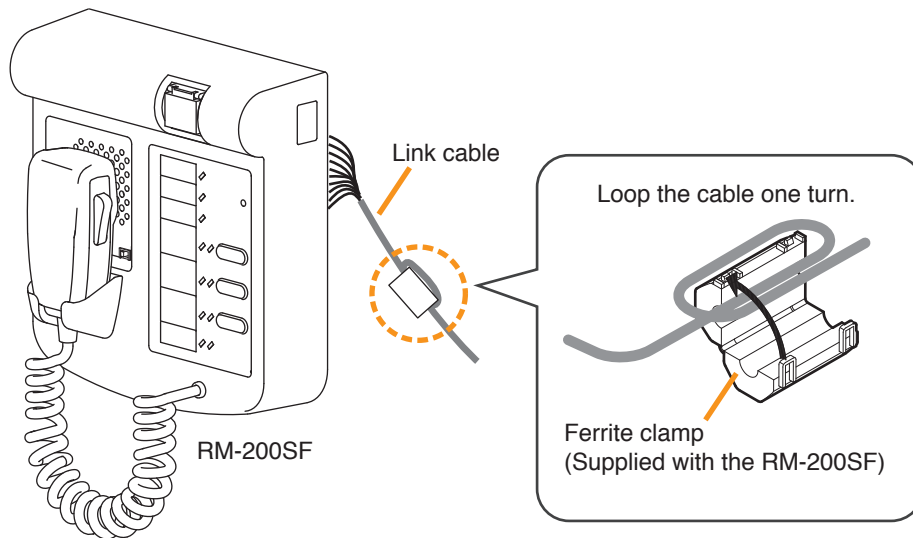

Mount the ferrite clamp (supplied with the RM-200SF) on the cable in a way that the cable is looped one turn as illustrated. (This countermeasure is for complying with the CE marking.)

[Installation]

Step 1. Install the wall mount bracket unit supplied with the RM-200SF on the wall.

1-1. Installing directly on the wall

Install the unit on the wall using 2 screws or more depending on the installation location. The RM-200SF comes with 2 tapping screws 4 x 25 for direct wall mounting.

⚠ WARNING

- Install the unit only in a location that can structurally support the weight of the unit and the mounting bracket. Doing otherwise may result in the unit falling down and causing personal injury and/or property damage.
- Be sure to install the bracket on the wall using 2 or more screws.

Notes

- Six mounting holes indicated by arrows in the figure below can be used for securing.
- When securing the unit with 2 screws, be sure to use a pair of holes located in the middle of the Bracket A.

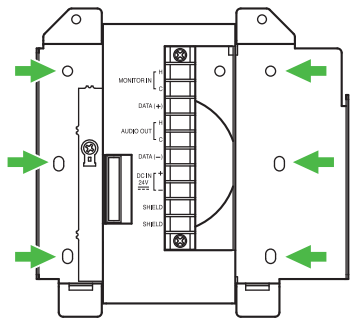

Wall mount bracket unit (supplied with the RM-200SF)

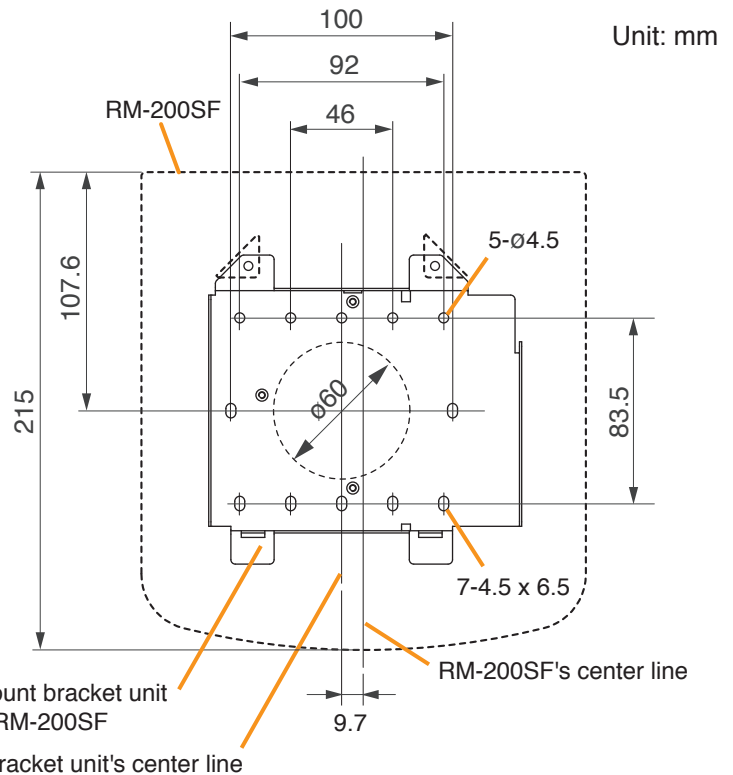

Wall mount bracket unit for the RM-200SF
Wall mount bracket unit's center line

1-2. Installing to a 1-gang electrical box

- (1) Unscrew 3 screws (indicated by arrows in the figure at right) that fix the Bracket A to the Bracket B of the wall mount bracket unit.

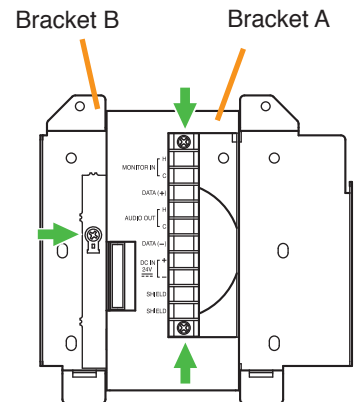

Wall mount bracket unit (supplied with the RM-200SF)

(2) Slide the Bracket A as show below to detach it from the Bracket B.

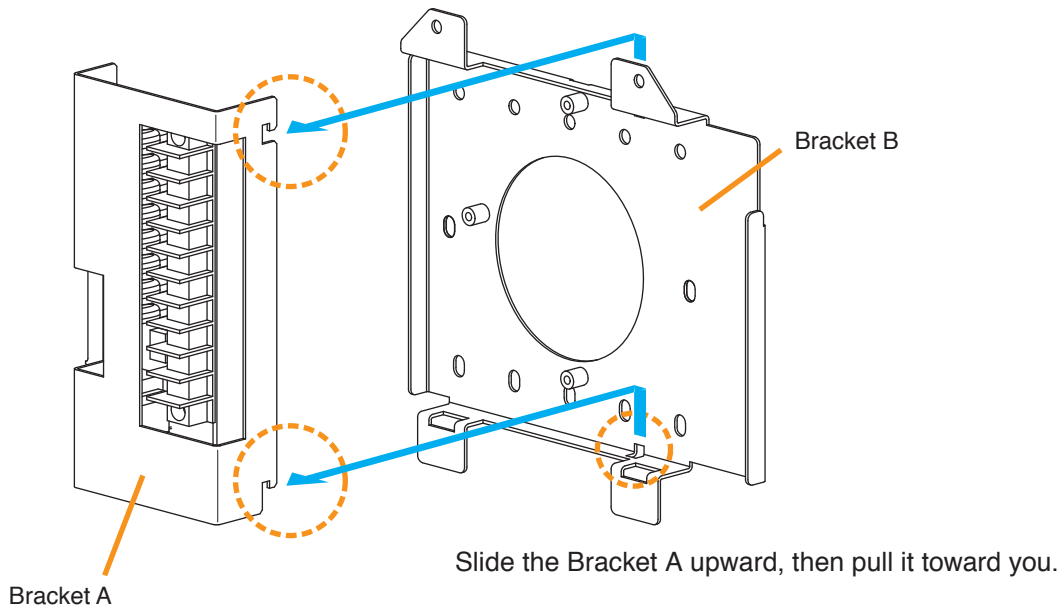

(3) Attach the Bracket B to the electrical box using 2 screws M3.5 x 20 supplied with the RM-200SF.

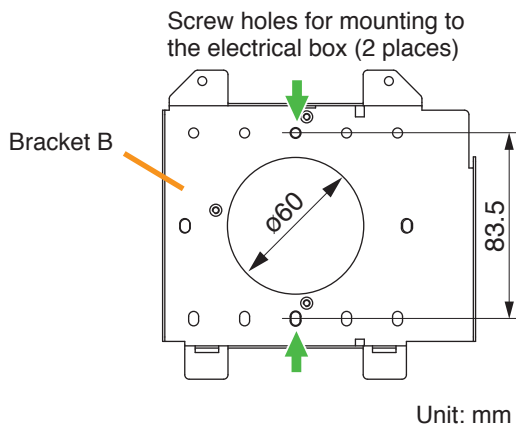

(4) Replace the Bracket A.
Reverse the procedures (1) and (2) above.

Note

Take care not to pinch the routed link cable between the Brackets A and B.

Step 2. Connect the link cable to the screw terminal block.

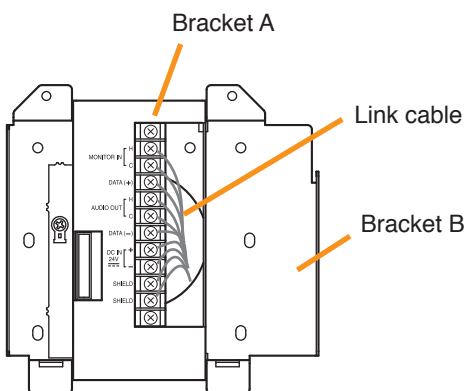

Wall mount bracket unit
(supplied with the RM-200SF)

Note

Put the link cable inside the Bracket A after connection completion.
Do not allow the link cable to protrude.
The cable may be damaged if it protrudes when the bracket unit is installed onto the wall.

Step 3. Plug the RM-200SF's extension connector into the connector port on the wall mount bracket unit.

Step 4. Attach the RM-200SF unit to the wall mount bracket unit.

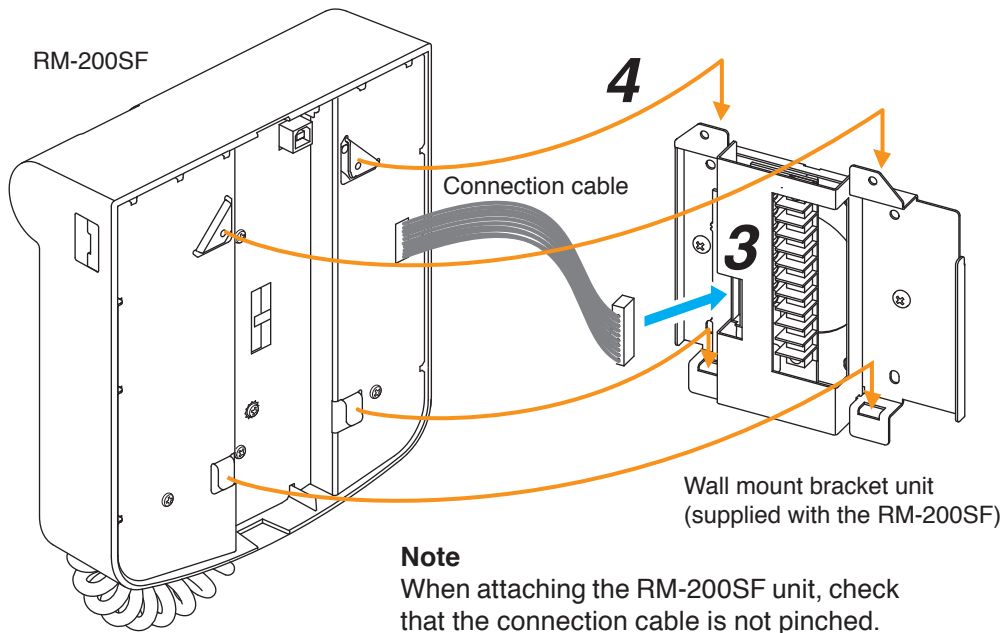

[When the RM-200SF is installed in a wall box]

When the RM-200SF is installed in a wall box (prepare separately), the box should measure at least 300 mm wide x 315 mm high as illustrated below.

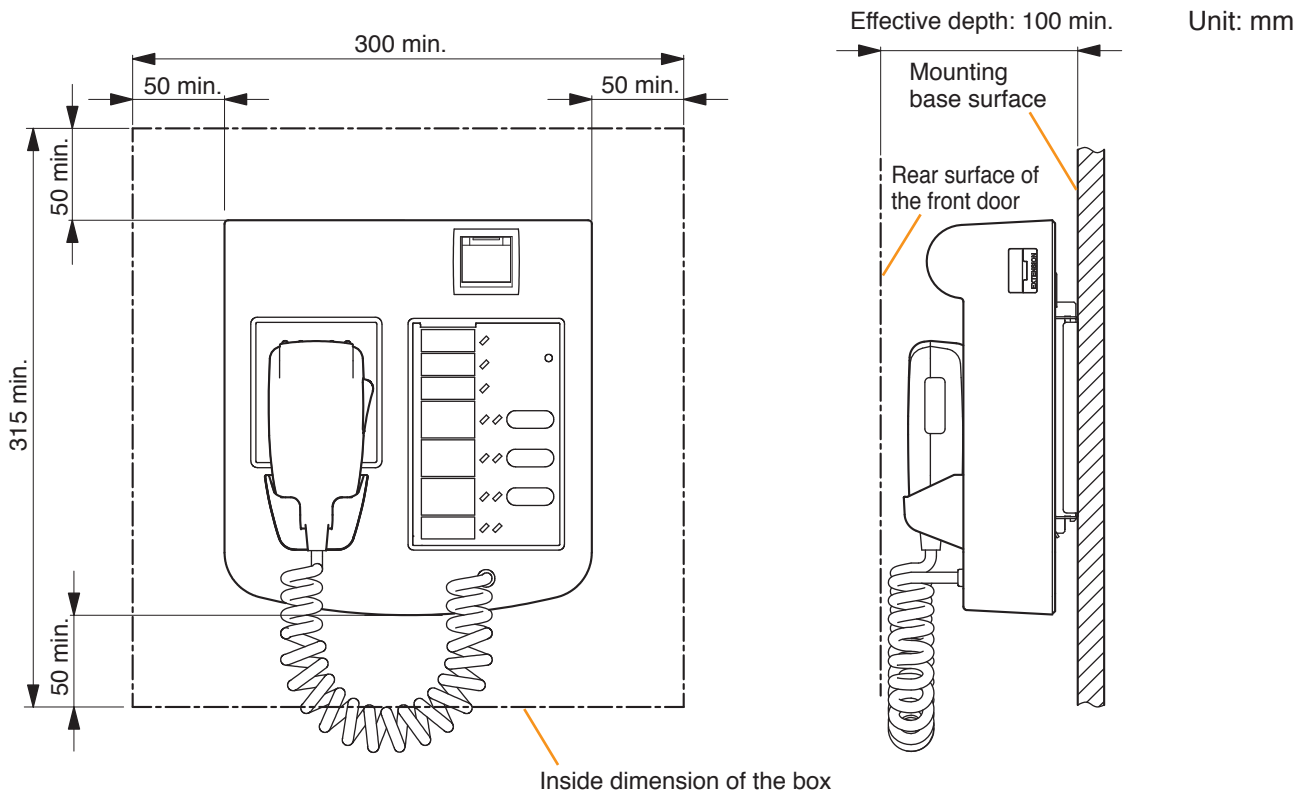

6.13. Installing the RM-320F on a Wall (RM-200SF only)

The RM-320F is designed for on-wall installation.

When adding an RM-320F Remote Microphone Extension to expand the RM-200SF, use the RM-320F's Extension cable and included Linkage Bracket to link the 2 microphones.

Up to 4 RM-320Fs can be connected to an RM-200SF.

[Mounting hardware]

To mount the RM-320F on the wall, the following parts are required.

Wall mount bracket unit 1 (supplied with the RM-320F)

Wall mounting screws

4 x 25 tapping screw for wooden wall 2 (supplied with the RM-320F)

Step 1. Install the wall mount bracket unit supplied with the RM-200SF on the wall. (See p. 3-40 and p. 3-41, Steps 1 and 2.)

Step 2. Place the RM-320F's bracket so that it fits in the RM-200SF's bracket as shown below. Then, fix the RM-320F's bracket to the wall with the supplied 2 tapping screws.

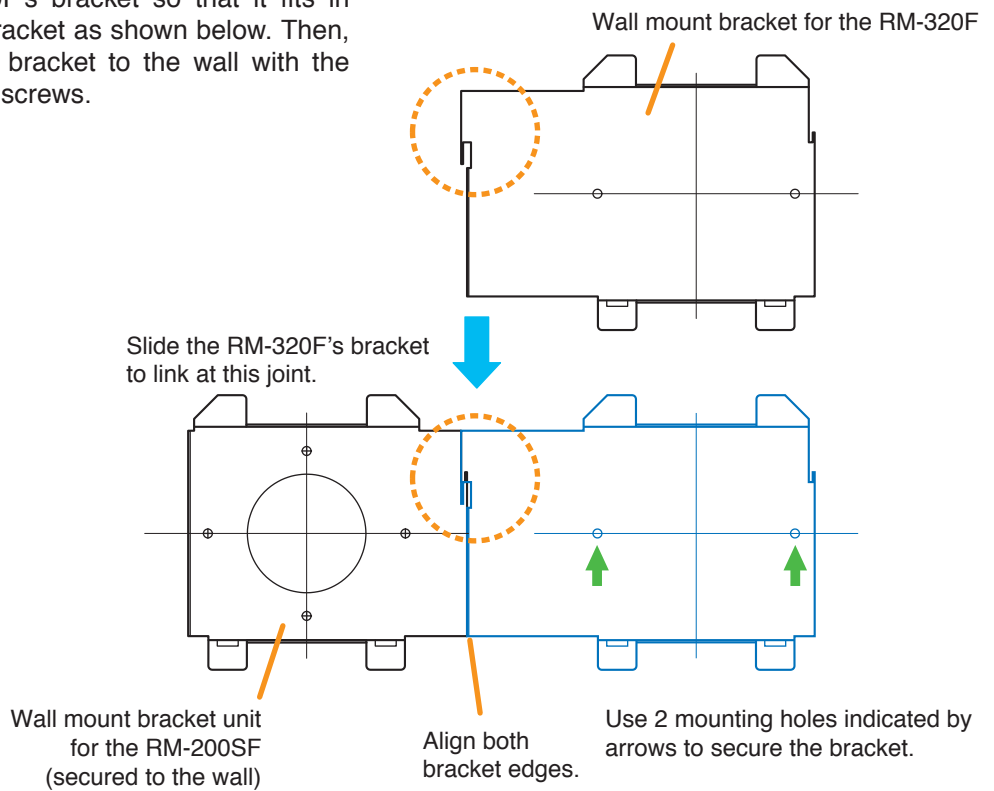

[Positional dimensions of the RM-200SF and RM-320F]

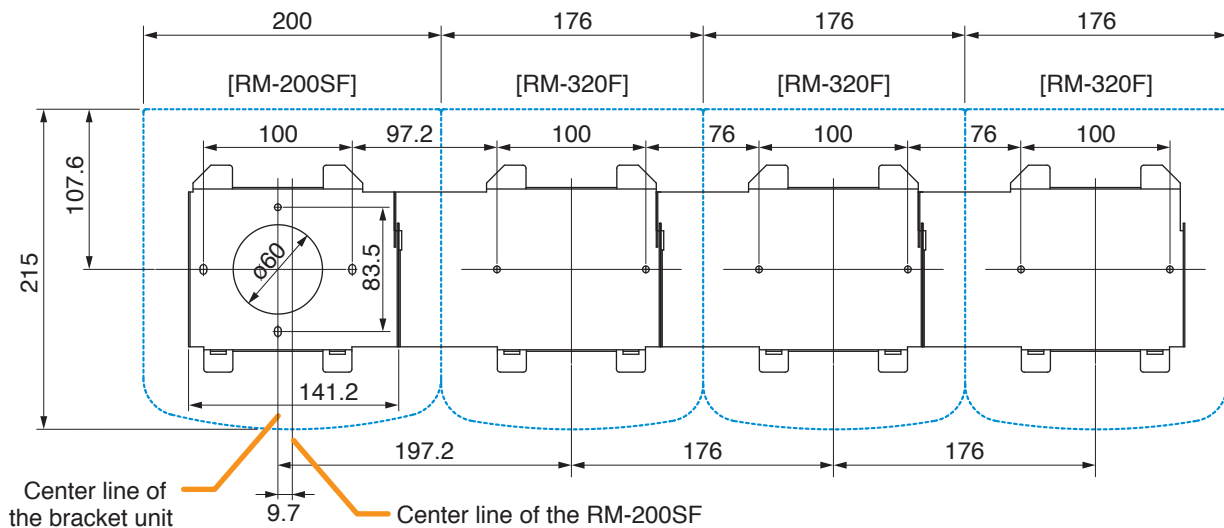

Step 3. Attach the RM-200SF to its wall mount bracket unit. (See p. 3-42, **Steps 3** and **4**.)

Step 4. Connect the RM-320F's cable to the extension connector on the RM-200SF's side.

Step 5. Install the RM-320F to its wall mount bracket sliding it in close contact with the RM-200SF as shown below.

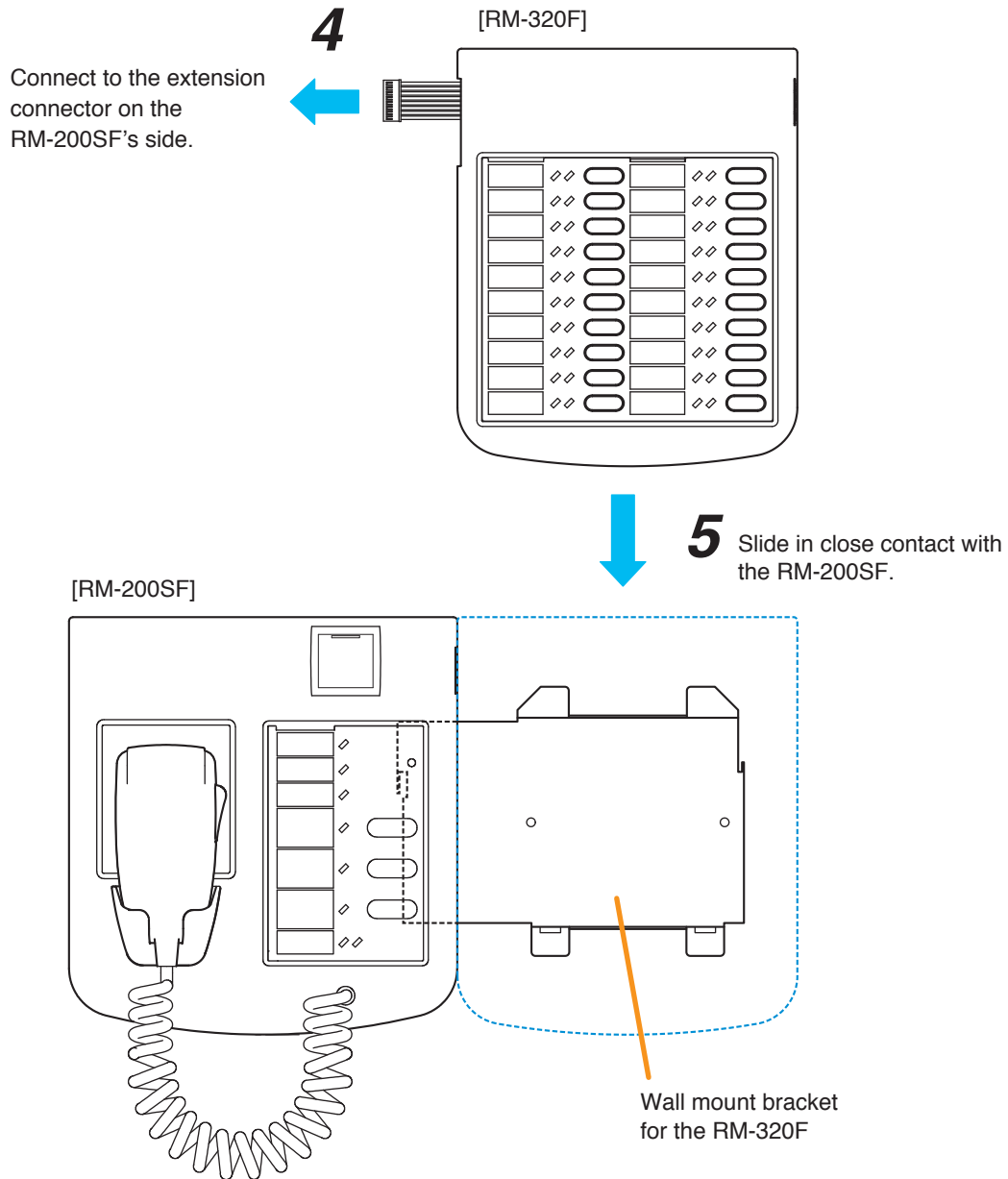

6.14. RM-300X Extension with the Addition of the RM-210F (Installed on a Flat Surface)

When adding an RM-210F Remote Microphone Extension to expand the RM-300X, use the RM-210F's Extension cable and included Linkage Bracket to link the 2 microphones. Up to 7 RM-210Fs can be connected to an RM-300X. After DIP switch setting completion, follow the procedures below.

[Mounting hardware (supplied with the RM-210F)]

Linkage Bracket A	2
Linkage Bracket B	1
Screw	12

Step 1. Turn over both the RM-300X and the RM-210F, and keep them in close contact with each other.

Step 2. Connect between both units using the extension cable supplied with the RM-210F.

Step 3. Using 4 supplied screws indicated by arrows and Linkage Bracket B, link both units together.

Step 4. Using 8 supplied screws indicated by arrows and 2 pieces of Linkage Bracket A, fix both units securely.

Note: To add another RM-210F to the installed RM-210F, use the similar procedures as in this section.

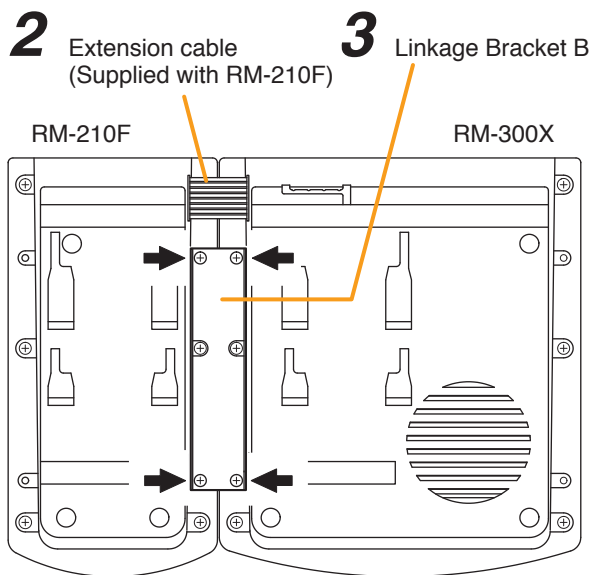

[Bottom side]

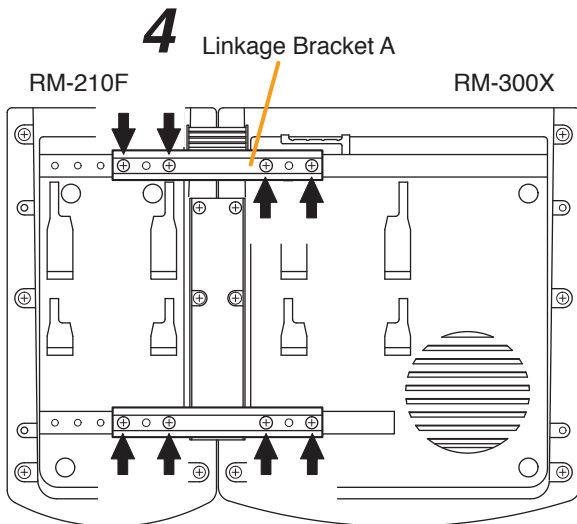

[Bottom side]

Notes

- Because the Linkage Bracket A is provided with 2 spare screw holes, use them to link the 2 units if the designated screw threaded holes are damaged.
- If incorrect or loose connection is found between both units, loosen all the bracket fixing screws to disassemble the units and then link them again with the screws.

6.15. Installing the RM-300X on a Wall

[Mounting hardware]

To mount the RM-300X on the wall, the following parts are required.

- Wall mounting bracket for the RM-300X (model WB-RM200) 1 (option)
- M3.5 x 20 screw for electrical box 2 (supplied with the WB-RM200)
- 4 x 25 tapping screw for wooden wall 2 (supplied with the WB-RM200)

Step 1. Attach the WB-RM200 Wall-Mounting Bracket on the wall.

In this case, leave the LINK cable out of the notch in the bracket.

Note

Since there are 2 types of mounting screws for an electrical box and for wall. Select ones according to the mounting method.

[WB-RM200 mounting dimensions]

Unit: mm

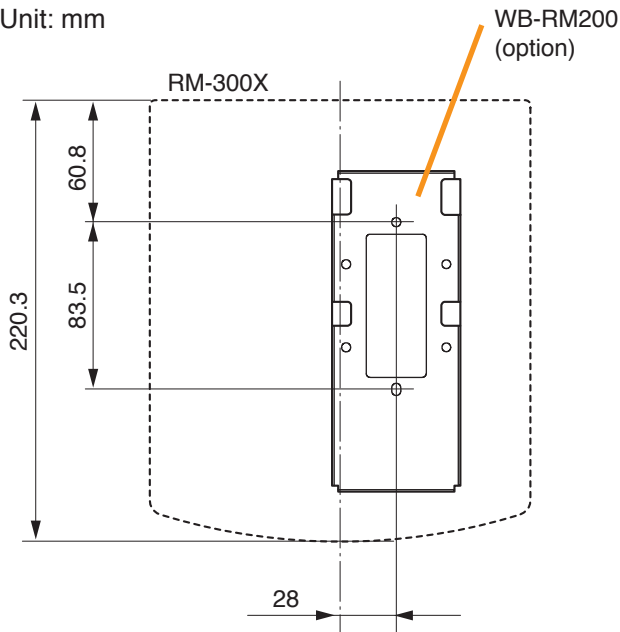

⚠ WARNING

- Install the unit only in a location that can structurally support the weight of the unit and the mounting bracket. Doing otherwise may result in the unit falling down and causing personal injury and/or property damage.
- Be sure to use 2 screws when mounting the bracket to the wall.

Step 2. Hook the bottom surface of the RM-300X onto the WB-RM200.

Step 3. Plug the LINK cable into the RM-300X's RM link connector.

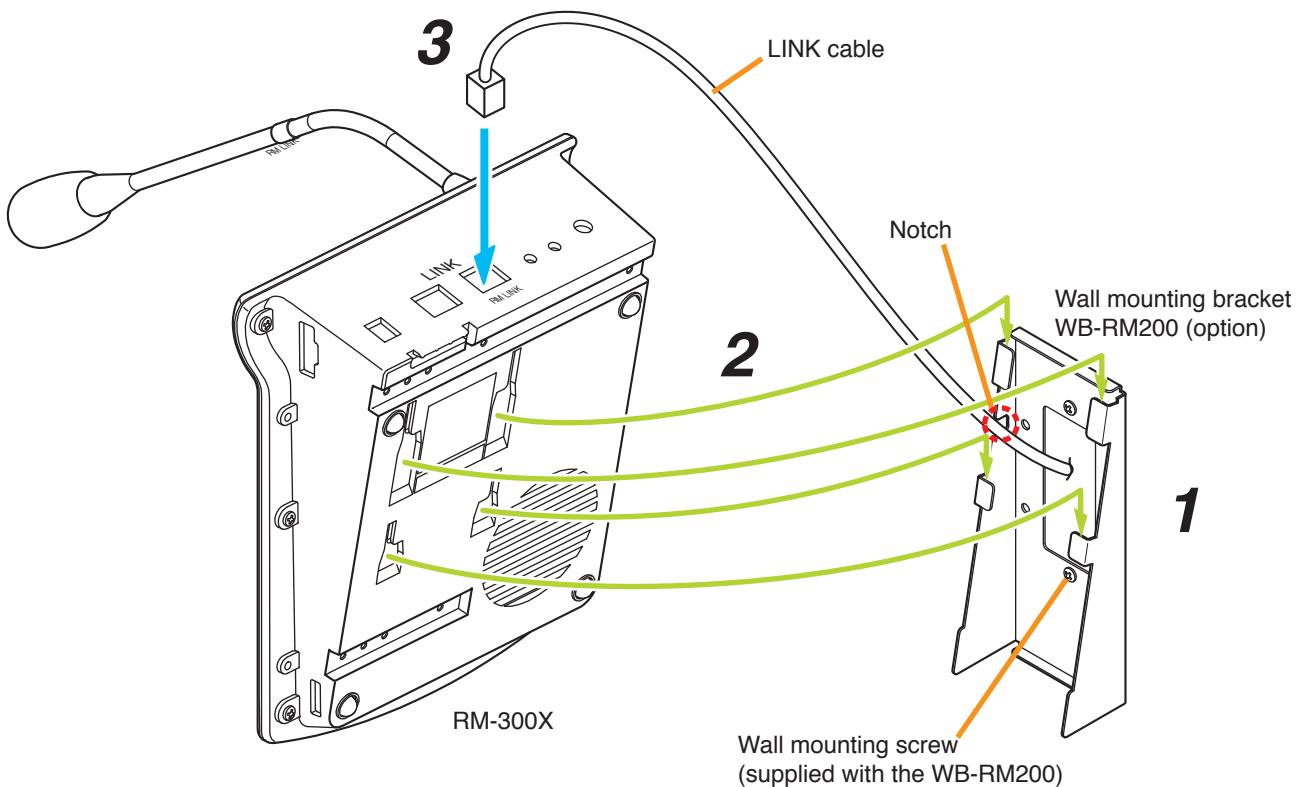

6.16. Installing the RM-210F on a Wall (RM-300X Only)

[Mounting hardware]

To mount the RM-210F on the wall, the following parts are required.

- Wall mounting bracket for the RM-210F (model WB-RM 200) 1 (option)
- M3.5 x 20 screw for electrical box 2 (supplied with the WB-RM200)
- 4 x 25 tapping screw for wooden wall 2 (supplied with the WB-RM200)

Step 1. Mount the RM-300X on the wall. (See p. 3-46.)

Step 2. Attach the WB-RM200 Wall-Mounting Bracket for mounting the RM-210F on the wall.

[WB-RM200 mounting dimensions]

Unit: mm

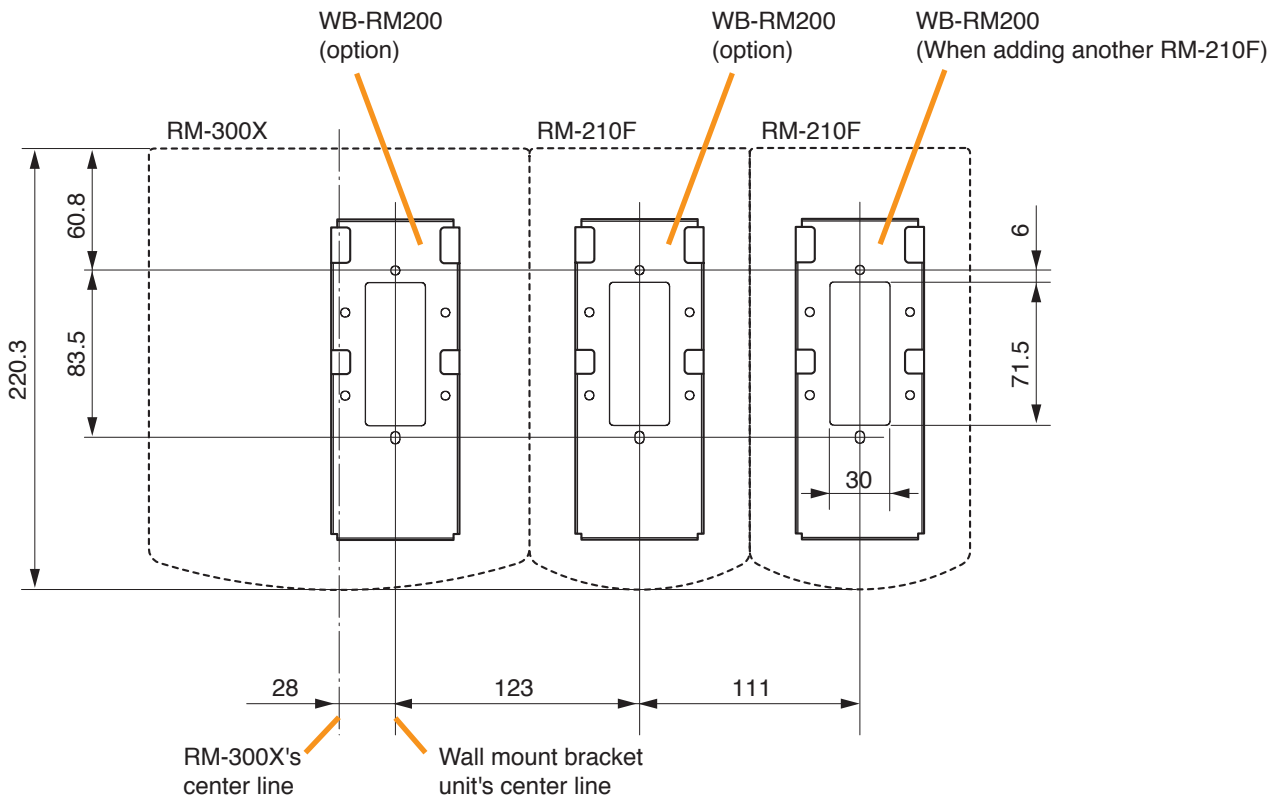

Step 3. Using the extension cable supplied with the RM-210F, connect the RM-300X's side EXTENSION connector to the RM-210F's side EXTENSION connector.

Step 4. Hook the bottom surface of the RM-210F onto the WB-RM200.

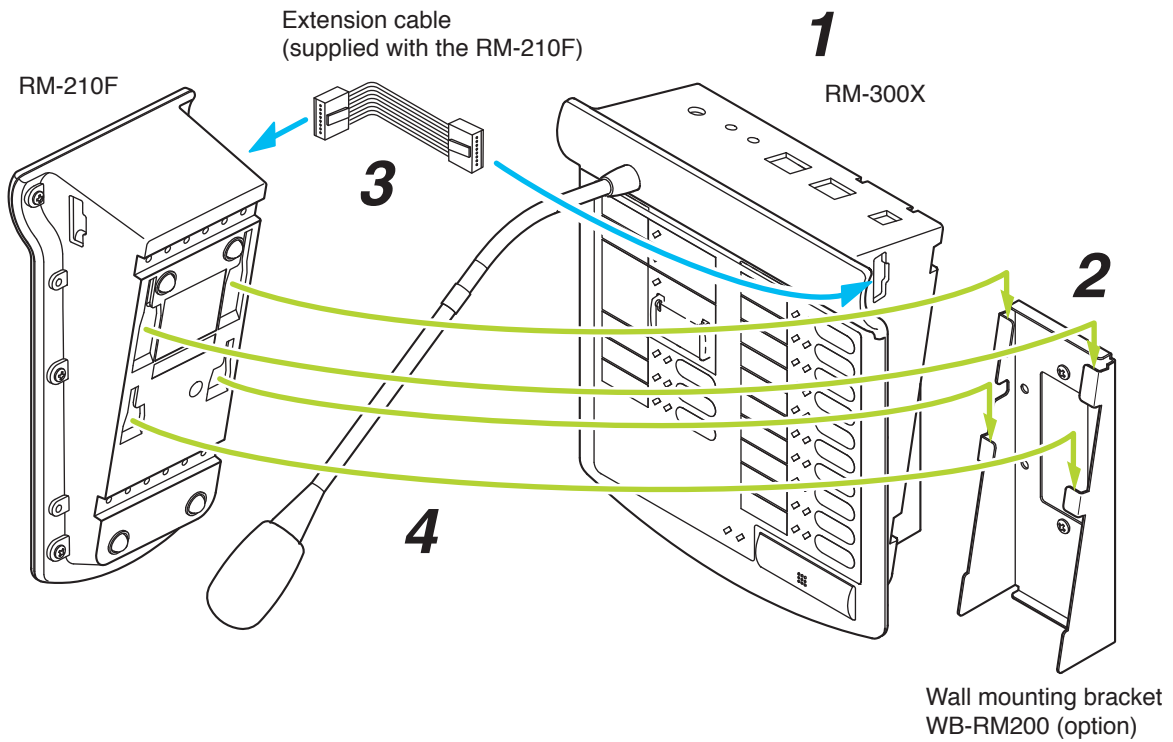

6.17. Installing the RM-500 on a Wall

[Mounting hardware]

To mount the RM-500 on the wall, the following parts are required.

Wall mounting bracket WB-RM500	1 (option)
4 x 25 tapping screw (for direct wall mounting)	2 (supplied with the WB-RM500)
M4 x 20 machine screw (for mounting to the switch box)	2 (supplied with the WB-RM500)

6.17.1. Changing the orientation of the microphone

The RM-500's microphone is installed in the orientation shown on the right figure by default.

When mounting the RM-500 on the wall, change the orientation of the microphone following the procedure below.

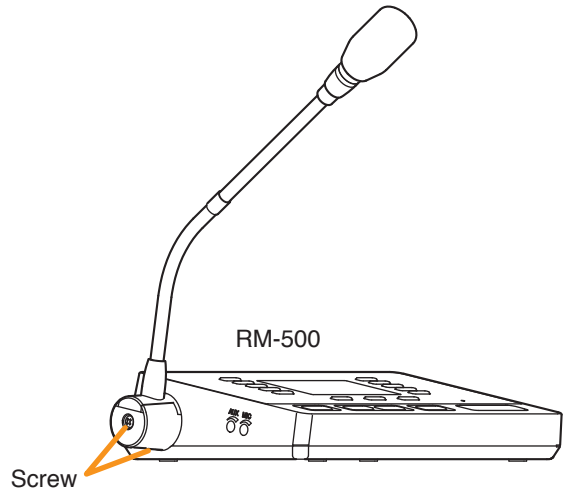

Step 1. Remove 2 screws securing the microphone, then detach the microphone fixing cover.

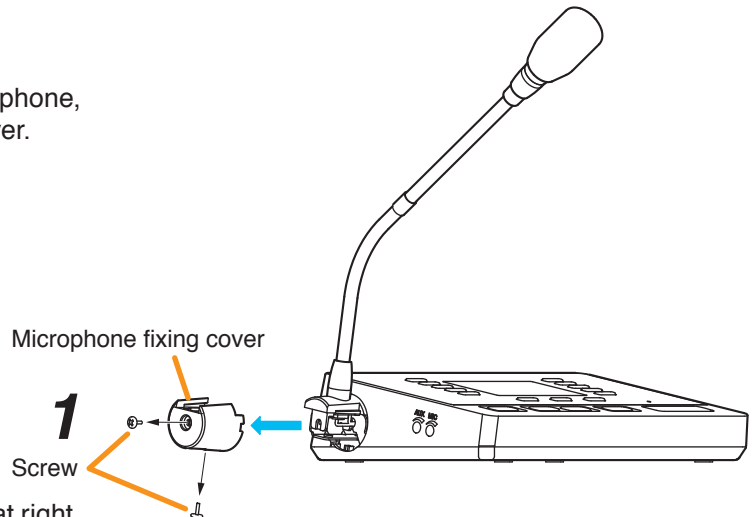

Step 2. Rotate the microphone 90° as shown at right.

Note

The microphone can be fixed only at the specified angle.

Be careful not to pinch the cable when rotating it to avoid damage to the cable.

Doing otherwise may result in malfunction.

Step 3. Attach the microphone fixing cover so that it fits in place to fix the microphone, then secure the cover with 2 screws removed in **Step 1**.

Notes

- Be sure to install the screws ① first, then ② in the figure.
- When securing the cover, be sure to check the screw holes and tighten the screws correctly.

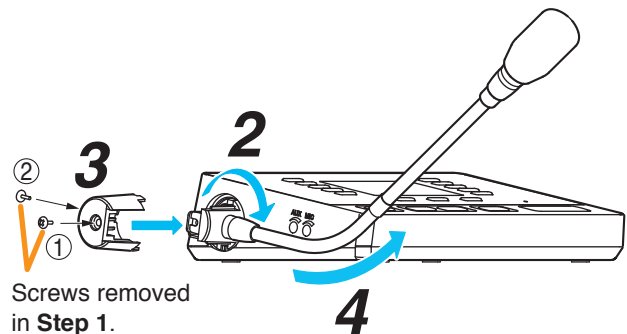

Step 4. Change the direction of the microphone for an appropriate position.

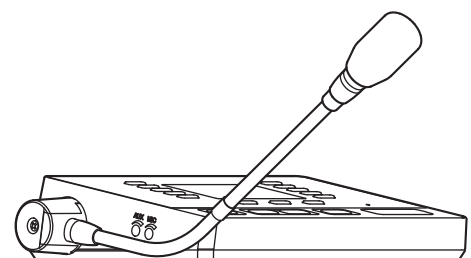

6.17.2. Hanging the RM-500 on the wall

Step 1. Install the WB-RM500 on the wall.

Use 2 or more screws to install the WB-RM500 on the wall depending on the installation location. The WB-RM500 comes with 4 x 25 tapping screws (2 pcs.) for direct wall mounting and M4 x 20 machine screws (2 pcs.) for mounting to the switch box.

⚠ WARNING

- Install the unit only in a location that can structurally support the weight of the unit and the mounting bracket. Doing otherwise may result in the unit falling down and causing personal injury and/or property damage.
- Be sure to use 2 or more screws to secure the mounting bracket on the wall.

Notes

- Install the WB-RM500 taking at least 90 mm long space up from its direct wall mounting hole. Insufficient space will not allow the installation of the RM-500.
- Secure the WB-RM500 using 2 direct mounting holes or 2 holes for the switch box in the figure below.
- Install the WB-RM500 in correct orientation referring to the “UP” mark engraved on it as a guide.

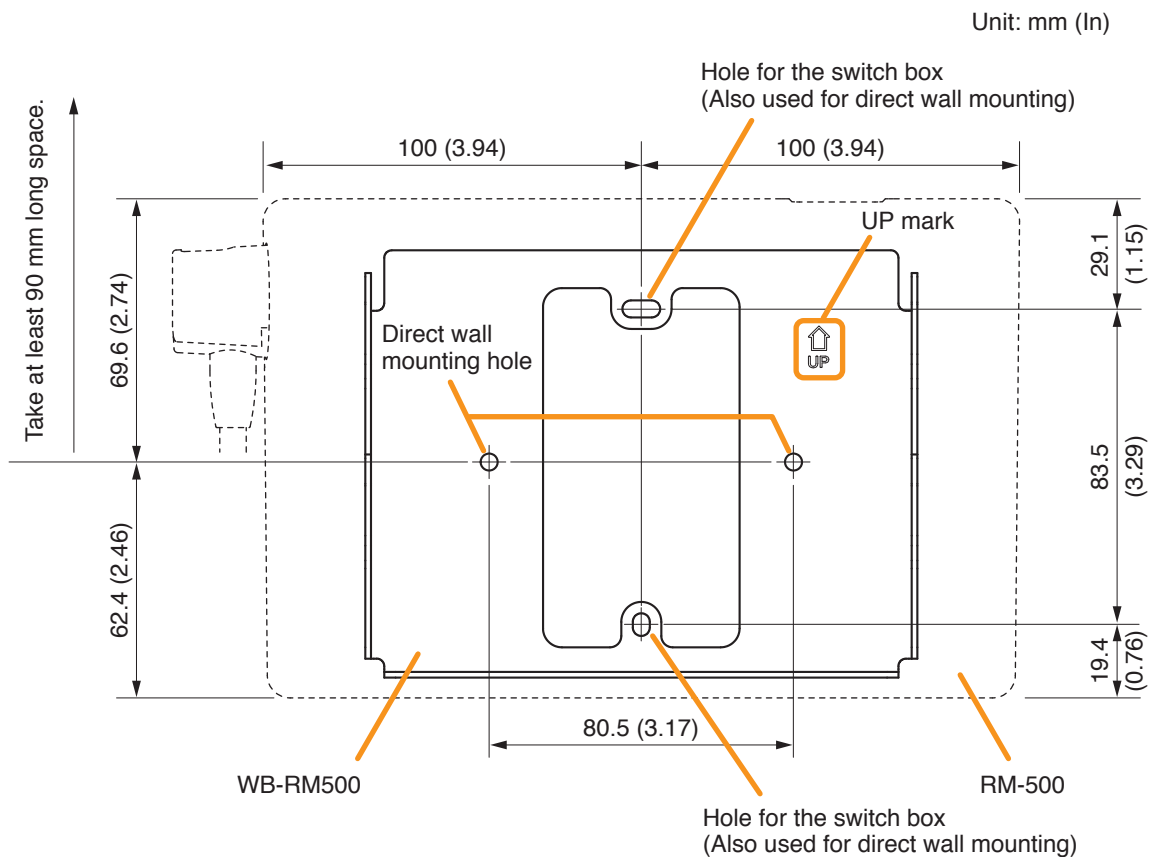

Step 2. Connect the cable from the VX-3000F to the RM-500.

Two methods are available for cable wiring: Wiring through the wall and Exposed wiring from the upper or lower side of the RM-500.

For the cable connection to the push-in terminal block, see p. 3-58.

[When wiring through the wall]

Extract the cable from the wall, pass it through the opening in the WB-RM500, then connect it to the push-in terminal block.

[When making exposed wiring]

Connect the cable to the RM-500's push-in terminal block, then extract it through the gap between the RM-500 and the WB-RM500.

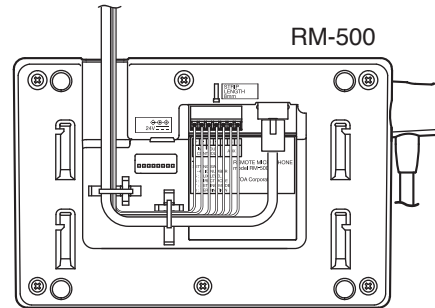
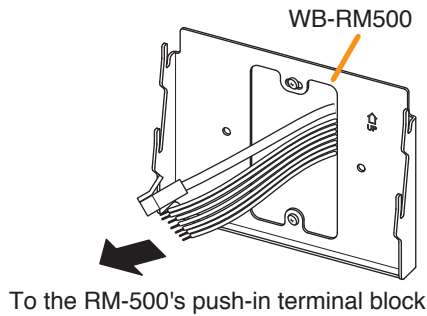

Step 3. Hang the RM-500 onto the WB-RM500.

Securely insert 4 mounting holes in the RM-500 into 4 protrusions of the WB-RM500 aligning them with each other.

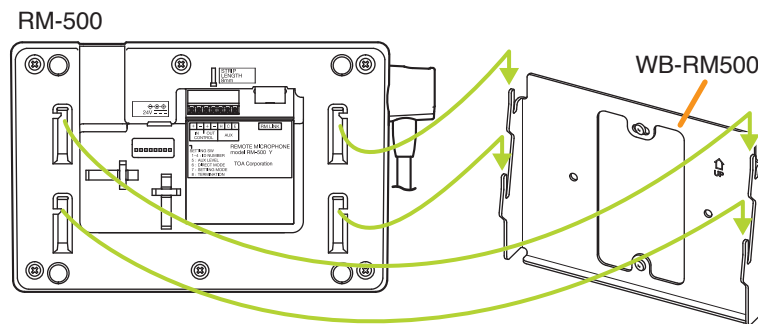

Note

After installation, make sure that the joints at all 4 places are correctly fit and have no looseness or rattling.

6.18. Creating Remote Microphone Name Labels (RM-200SF, RM-320F, RM-300X, and RM-210F only)

Using the VX-3000 Setting Software function, assigned names of preset RM-200SF, RM-320F, RM-300X, and RM-210F Function keys can be printed out. Once printed, cut out the printed names with scissors to use them as corresponding name labels. The paper used for the name label must be under 0.2 mm in thickness.

Note

For creating and printing name labels using the VX-3000 Setting Software, see the separate Setting Software Instructions, "PRINTING LABELS FOR REMOTE MICROPHONES."

6.18.1. Inserting the name label

- Fully insert the name label cut to the instructed size into the label entry slit.
- To remove the label, pull it out of the slit using the tip of knife blade.

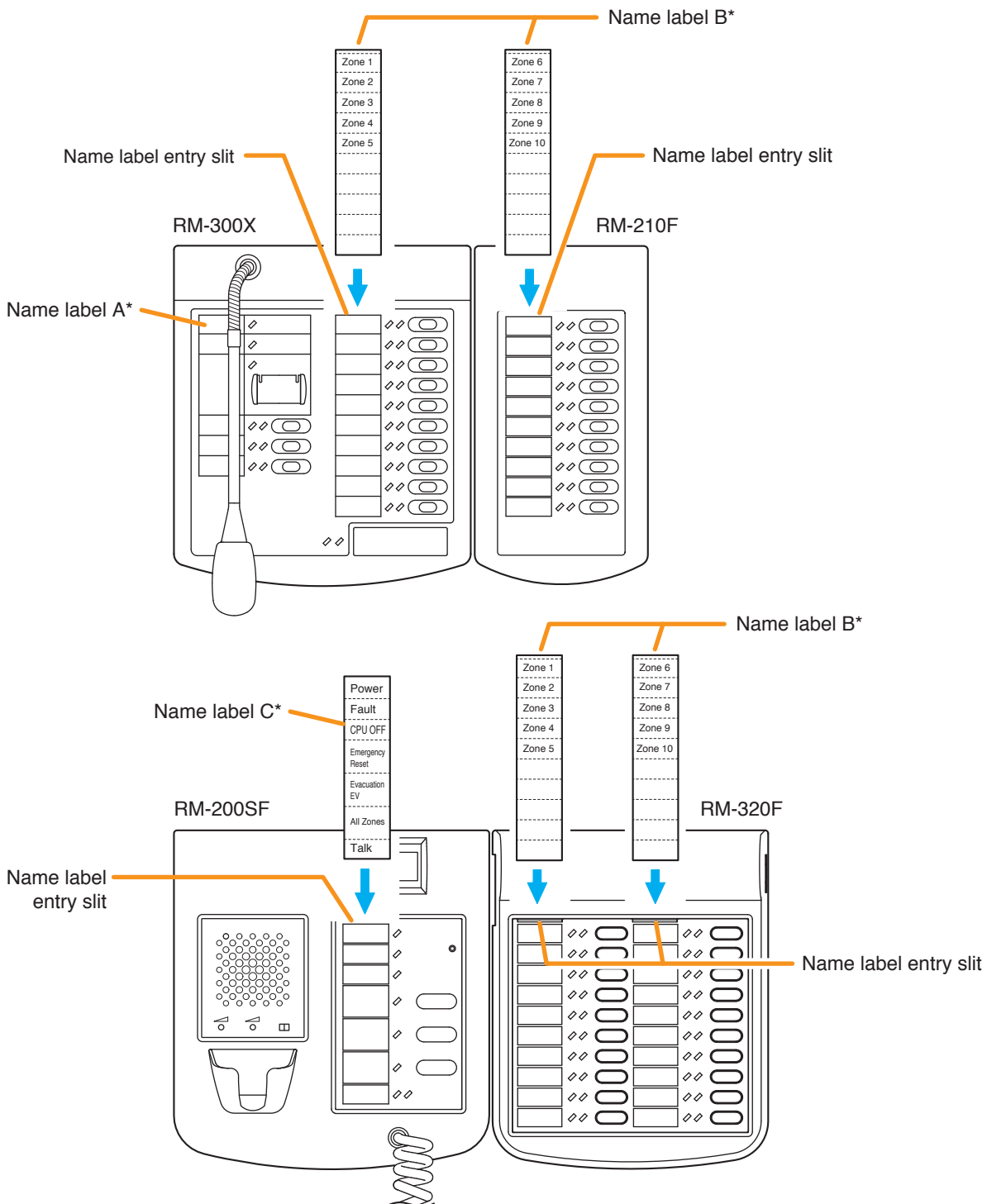

* Created and printed using the VX-3000 Setting Software.

6.18.2. If the name label is not printed correctly

The name label created using the VX-3000 Setting Software may not be printed in correct size depending on the configuration environment of your PC. In such cases, try one of the methods described below.

- (1) Preparation by hand
Copy the "Pattern paper for hand writing" on the next page. After writing a name, cut out the pattern paper aligning it with the cutting guidelines.
- (2) Preparation by using a PC or word processor
Prepare and print according to the instructions given in the "Dimensional diagram for printing devices." Then cut out to the instructed size.

6.18.3. Dimensional diagram for printing devices

Name label A
Cutting size: 30 x 110 mm

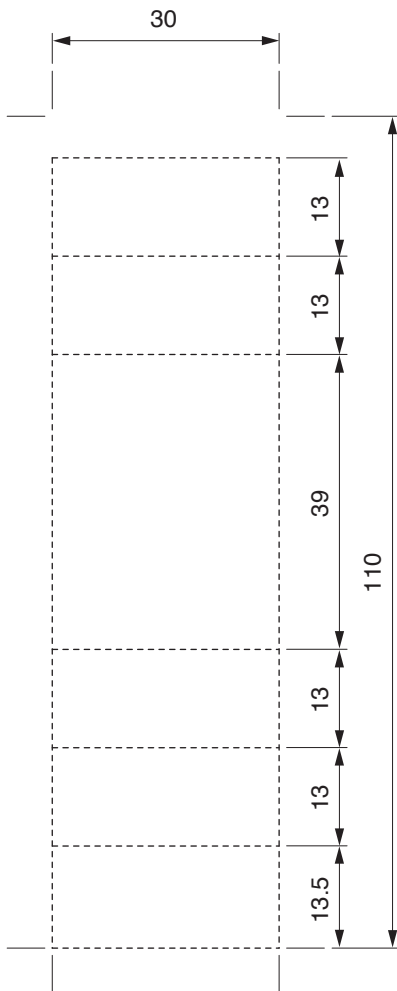

Name label B
Cutting size: 30 x 136 mm

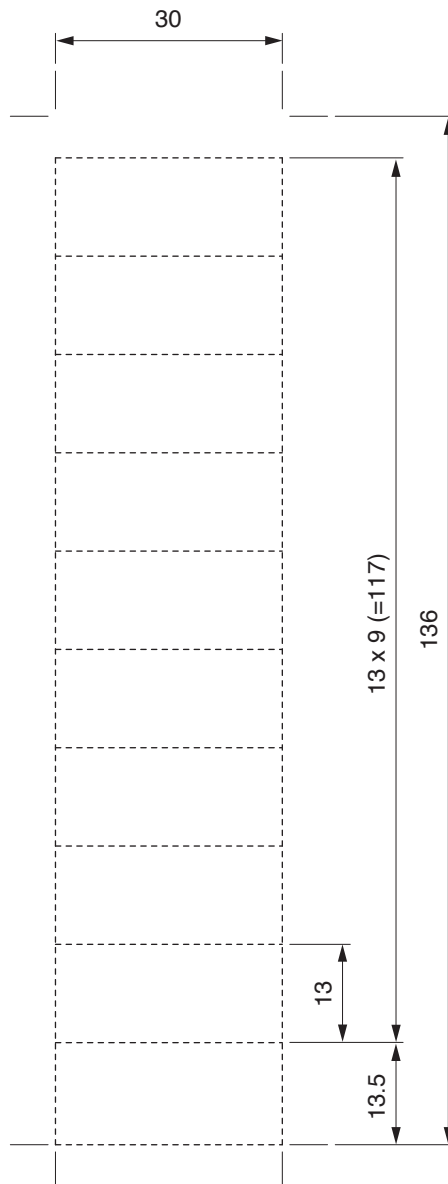

Name label C
Cutting size: 30 x 118 mm

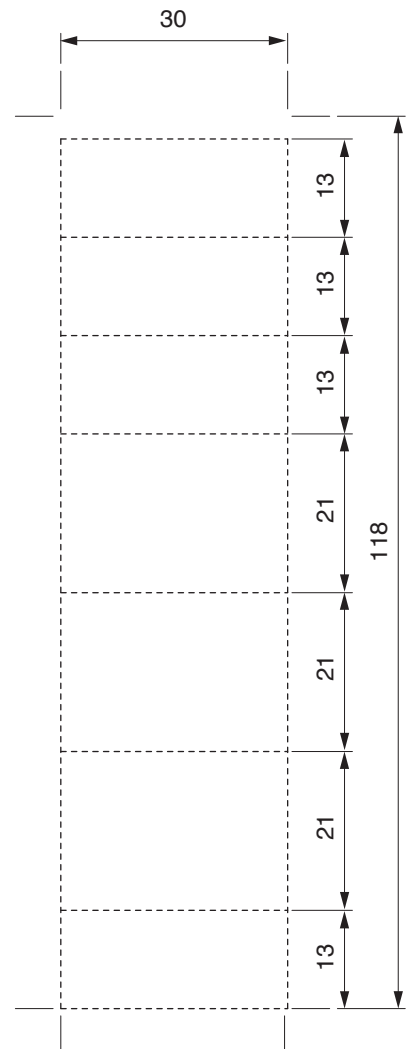

6.18.4. Pattern paper for hand writing

Name label A

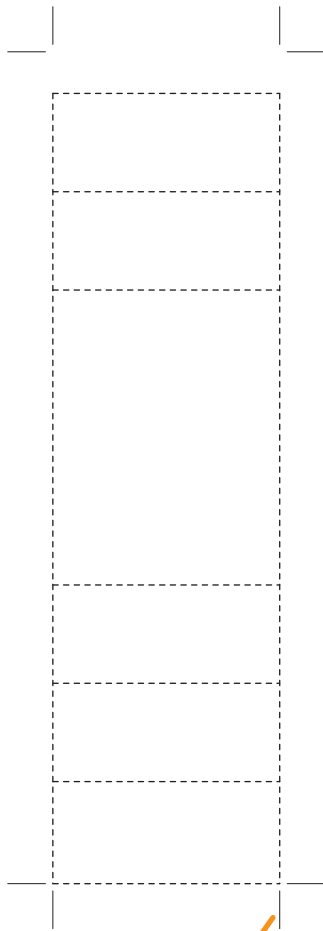

Name label B

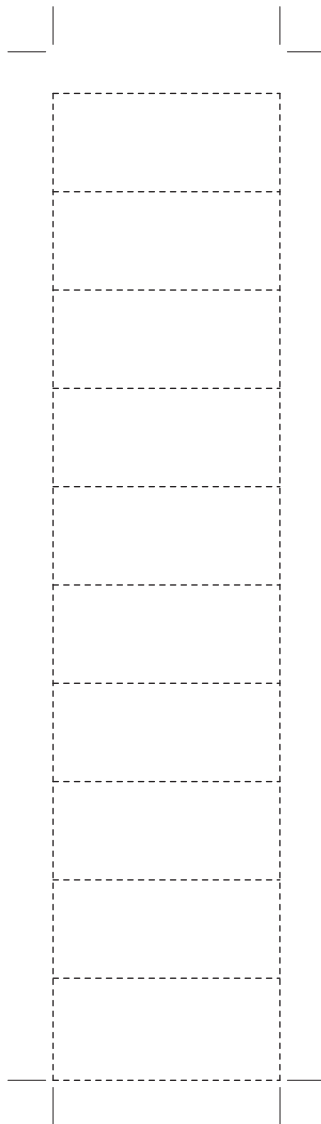

Name label C

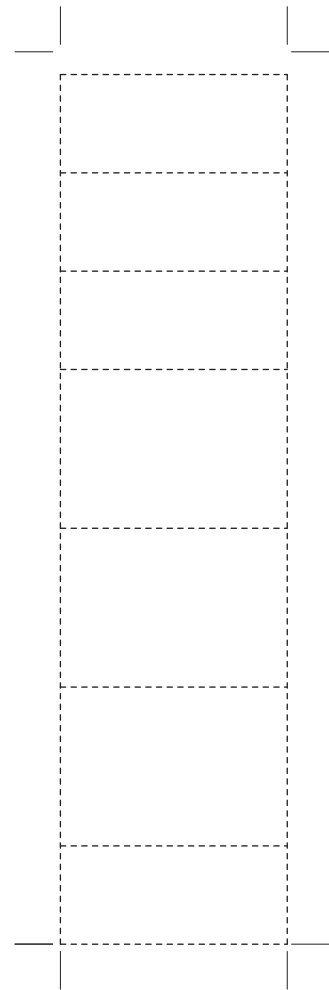

Cutting guideline



Shown in actual size

7. RACK MOUNTING

CAUTION

- (Applicable to VX-3000F only)
The supplied rack-mounting screws can be used for the TOA equipment rack only. Do not use them for other racks.
- (Applicable to VX-3000DS and VX-3150DS only)
Rack-mounting screws are not supplied with the unit. Prepare them that are appropriate for the equipment rack.

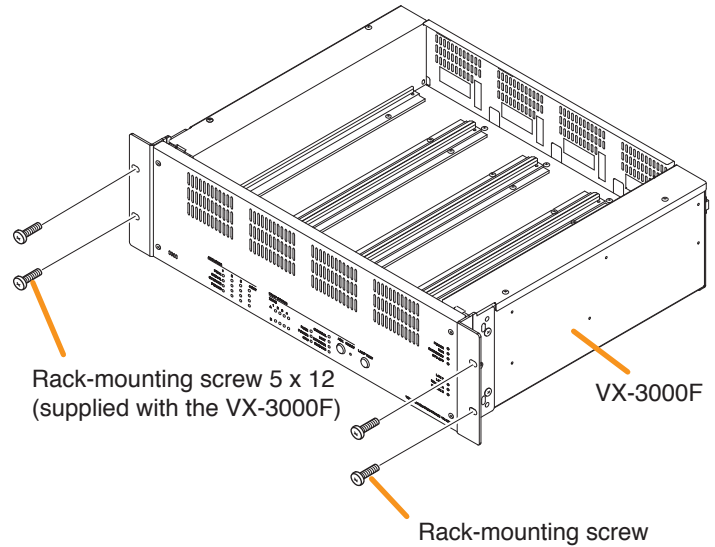

[Perforated panel mounting]

(Example)

Be sure to mount the PF-013B (1U) to the locations described below.

- Above the 2 installed VX-3000F units
- Above and below the 1 installed VX-3000DS or VX-3150DS unit
- At the uppermost and the lowermost positions of the cabinet rack

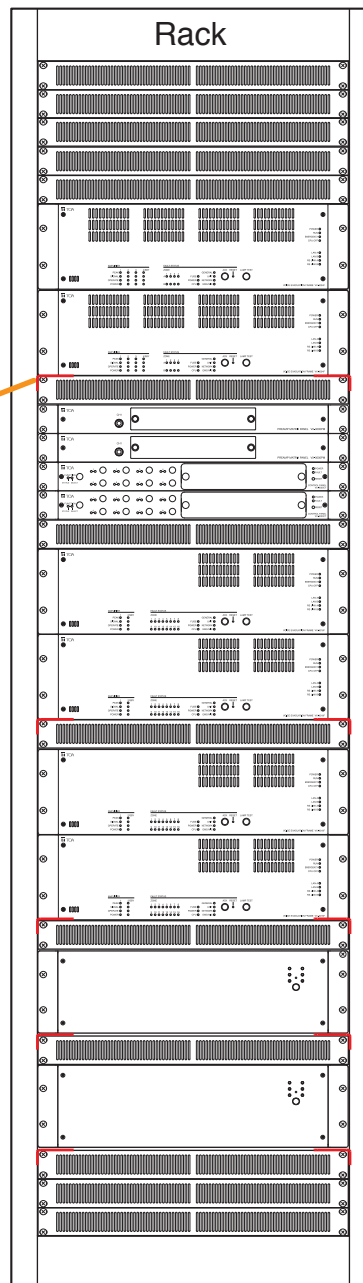

1	PF-013B	
2	PF-013B	
3	PF-013B	
4	PF-013B	
5	PF-013B	
6		
7	VX-3004F	
8		
9		
10	VX-3004F	
11		Supporting runner
12	PF-013B	
13	VX-3000PM	
14	VX-3000PM	
15	VX-3000CT	
16	VX-3000CT	
17	PF-013B	
18		
19	VX-3008F	
20		
21		
22	VX-3008F	
23		Supporting runner
24	PF-013B	
25		
26	VX-3016F	
27		
28		
29	VX-3016F	
30		Supporting runner
31	PF-013B	
32		
33	VX-3000DS	
34		Supporting runner
35	PF-013B	
36		
37	VX-3000DS	
38		Supporting runner
39	PF-013B	
40	PF-013B	
41	PF-013B	

[Supporting runner installation]

Be sure to install the supporting runner to the locations described below.

- Underside of the 2 installed VX-3000F units
- Underside of the 1 installed VX-3000DS or VX-3150DS unit

7.1. Affixing Declaration of Compliance (EN 54-16 Standard)

To declare that the VX-3000F complies with EN 54-16, affix the sticker supplied with the VX-3000F visible to the front panel of the equipment (e.g. at the upper right side as shown below).

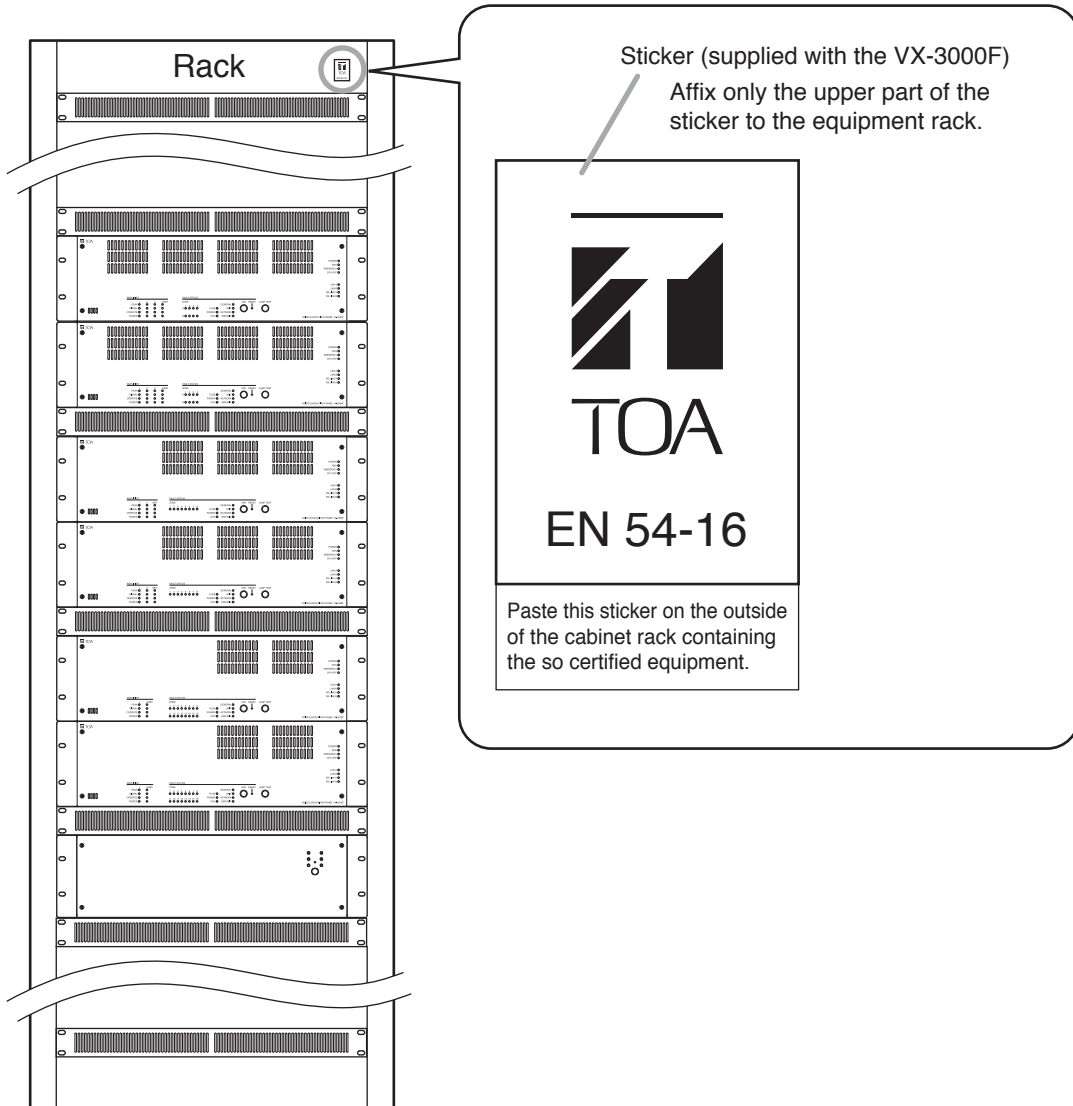

8. CONNECTIONS

8.1. Removable Terminal Plug Connection

Notes

- Do not use a micro screwdriver. Sufficient torque is not given to the screws when tightening them, and connections may not be secured.
- Avoid soldering stranded or shielded cable, as contact resistance may increase when the cable is tightened and the solder is crushed, possibly resulting in an excessive rise in joint temperatures.
- When connecting 2 cables or a shielded cable to a single terminal, use a ferrule terminal with an insulation sleeve to crimp the cables because such cable conductors could become loose.

Recommended ferrule terminals for signal cables
(made by DINKLE ENTERPRISE)

	Model Number	a	b	l ₁	l ₂
①	DN00308D	1.9	0.8	12	8
②	DN00508D	2.6	1	14	8

Unit: mm

Recommended ferrule terminals for power supply cables
(made by DINKLE ENTERPRISE)

	Model Number	a	a ₁	a ₂	b	l ₁	l ₂
③	DN01508D	3.5	—	—	1.7	14	8
④	DN01508B	—	6.6	3.6	2.3	16	8

Unit: mm

Crimping tool: DNT01-2206B (made by DINKLE ENTERPRISE)

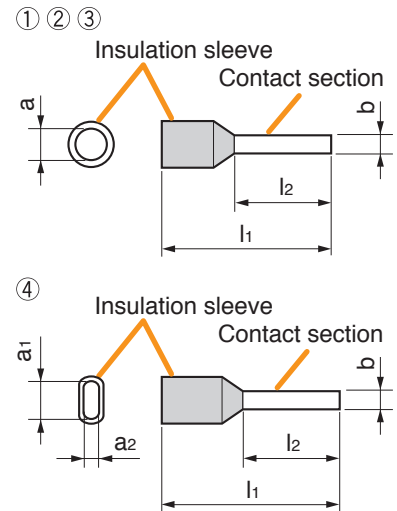

[Cable sheath to trim]

Solid cable and stranded cable

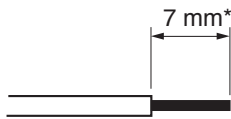

Shielded cable

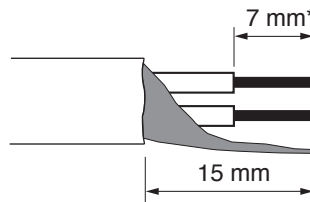

* Expose 8 mm or more when using the above ferrule terminal, and cut off an extra conductor protruding from the sleeve.

[Wiring procedures]

Procedures below are for the removable terminal plug with fixing screws.

Step 1. Loosen the terminal screw and insert the cable lead.

Step 2. Tighten the screw.
Pull on the cable lead to ensure it is securely connected.
If the lead pulls out, loosen the screw and follow the above procedures again.

Step 3. Insert the terminal plug into the corresponding terminal block in the unit's rear panel.

Step 4. Tighten the fixing screws.

Note

Do not reverse **Steps 1 – 2** and **3 – 4** above. Force is applied to the connected receptacle pins while tightening the terminal screw and they may be damaged, resulting in bad connector contact.

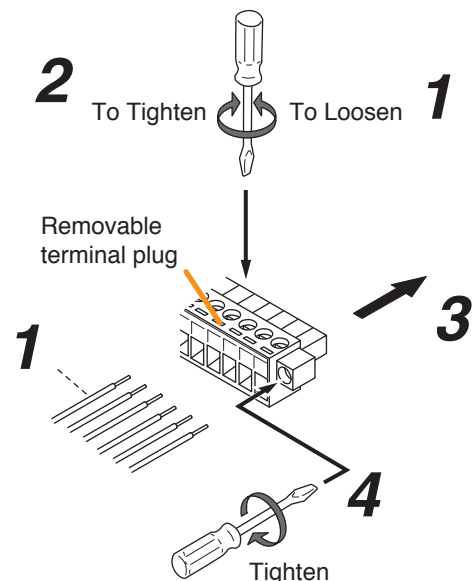

8.2. Connecting the Cable to the Push-in Terminal Block

Step 1. Strip the cable sheath 8 mm (0.31") from the cable end. Use the strip gauge in the bottom surface of the RM-500.

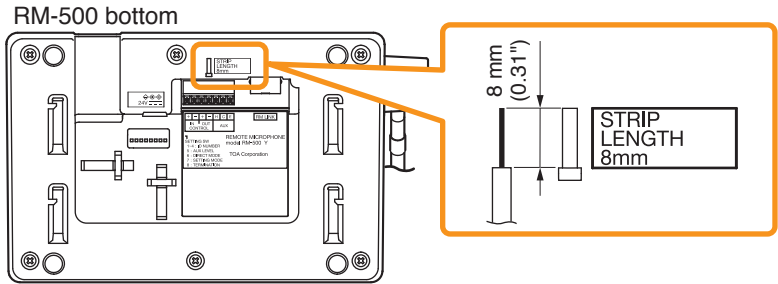

Step 2. Connect the cable.

2-1. For solid wire

Insert the cable fully into the hole of the push-in terminal block to the root of the bare wire.

[Recommended cables]

Diameter of core wire (copper wire): $\varnothing 0.4 - 1.1$ mm (AWG 28 - 17)

2-2. For stranded cable

Crimp the tip of the cable with a ferrule terminal.

[Recommended ferrule terminals]

Manufacturer	Model Number	Specification
Weidmuller	H0,75/14T HBL	8 mm (0.31")
Phoenix Contact	AI 0.75-8 BU - 320027	14 mm (0.55")

[Recommended harness]

18 AWG or smaller

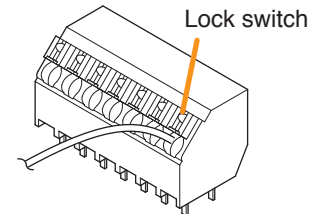

While pressing the lock switch on the upper side of the push-in terminal block, insert the cable fully into the hole of the terminal block to the root of the bare wire. Then, release the lock switch keeping the cable inserted.

Note

Do not press the lock switch by force.

Tip

To remove the cable, pull it out holding down the lock switch.

Step 3. After finishing the cable connections to all the terminals, bundle the cables with the zip tie.

When installing the RM-500 on a table, secure the bundled cables to the RM-500's bottom surface with 2 cord clamps so that the RM-500 will not be pushed up by the cables.

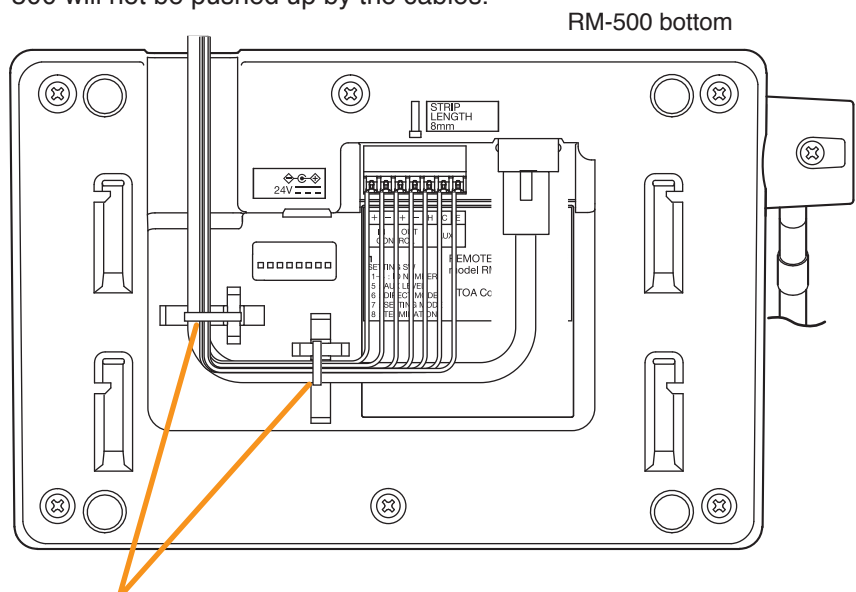

Bundle the cables and secure them to the fixing holes for wiring with the zip ties supplied with the RM-500.

8.3. Input Equipment Connections

8.3.1. Connecting the Remote microphone

- The VX-3000F is equipped with 2 channels of RS Links. Connect the remote microphone to one of these ports.

The number of connectable units is limited as follows.

(1) Up to 8 RM-200SF, RM-300X, or RM-500 units can be connected to a single VX-3000F.

(2) Up to 4 RM-200SF, RM-300X, or RM-500 units can be connected to a RS Link.

However, the VX-3000F can supply power to up to 2 units. An AC adapter is required for the RM-200SF, RM-300X, or RM-500 to be connected exceeding 2 units.

(3) The maximum cable length from each RS link is 1200 m.

(4) If the system is required to comply with EN54-16, observe the following restrictions.

- Out of 8 connectable remote microphones, the number of the connectable RM-200SF units or RM-300X units for emergency broadcasts is up to 2 in total, and 1 to a single channel of RS link.
- When connecting the RM-200SF or the RM-300X for emergency use directly to each VX-3000F's RS link, make its distance shortest compared to other remote microphones.

Note

When connecting the RM-500 to the RS LINK terminal to which the RM-200SF or the RM-300X is connected, the ID number "7" of the RM-500 cannot be used.

In this case, set the RM-500's ID number to between 0 and 6.

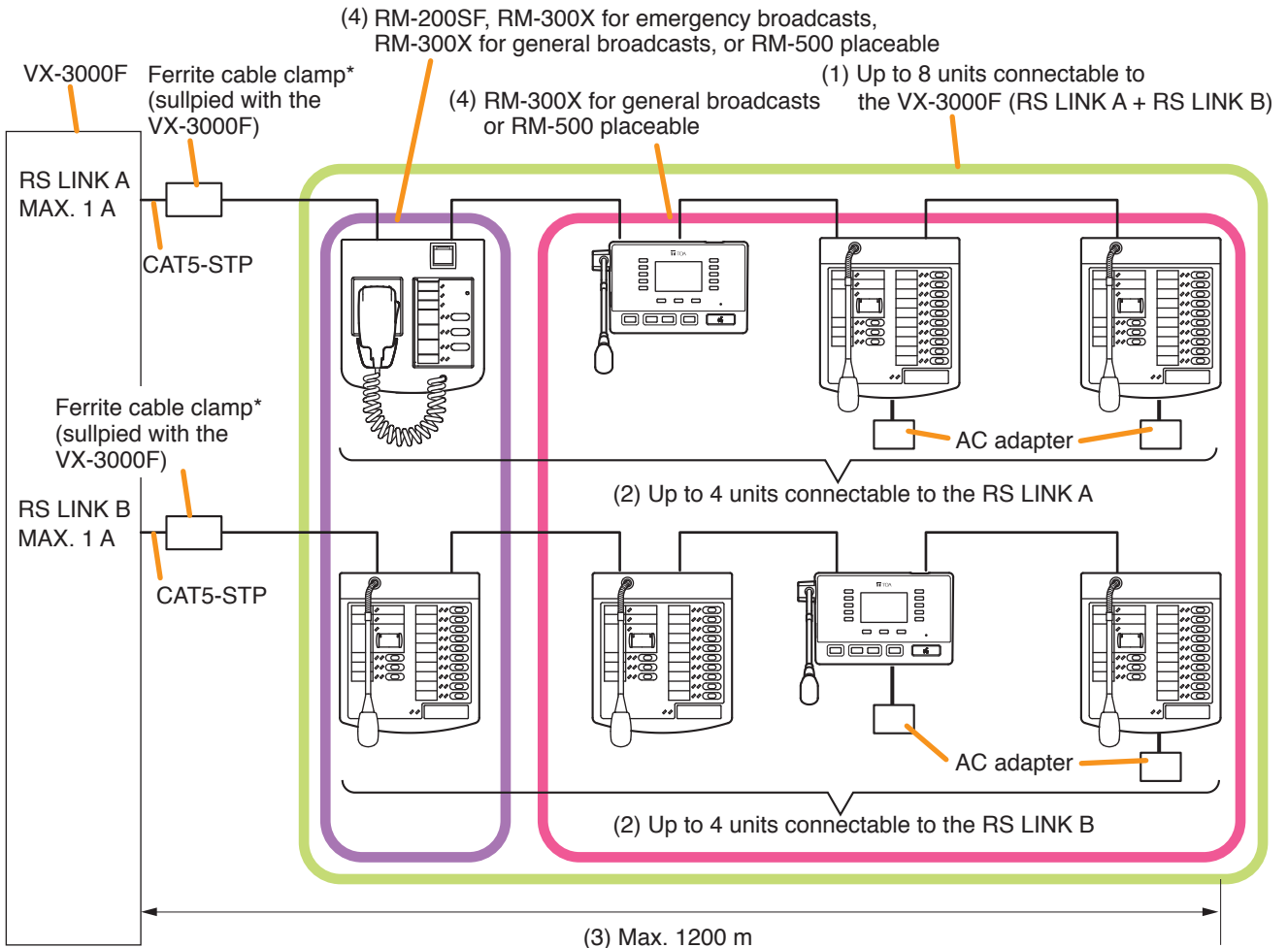

* Ferrite Cable Clamp Attachment

To reduce electromagnetic noise, place the supplied ferrite cable clamp over the Shielded Category 5 twisted pair cable (CAT5-STP) at a position within 20 cm (7.87") from the VX-3000F's RS link connectors.

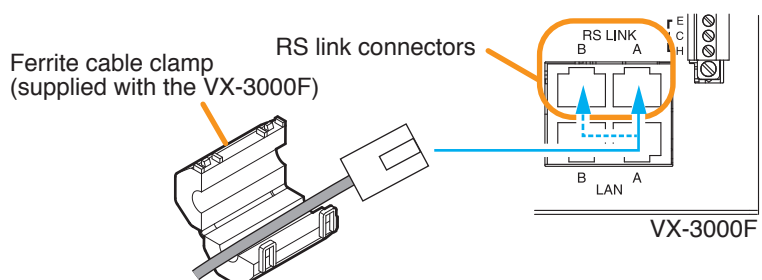

- When connecting 2 or more remote microphones to a RS LINK, make branch wiring using the RM-200RJ Terminal Unit or the Wall mount bracket unit supplied with the RM-200SF.

(When connecting 2 or more remote microphones: Example 1)

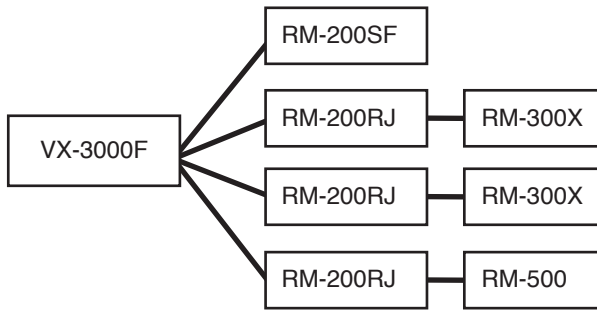

(When connecting 2 or more remote microphones: Example 2)

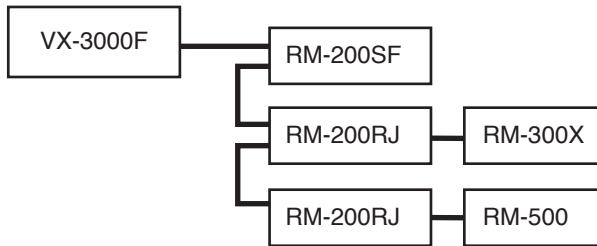

- The number of function keys can be increased by connecting the extension unit to the RM-200SF and RM-300X as shown below.

(1) Up to 4 RM-320F units can be connected to the RM-200SF.

(2) Up to 7 RM-210F units can be connected to the RM-300X.

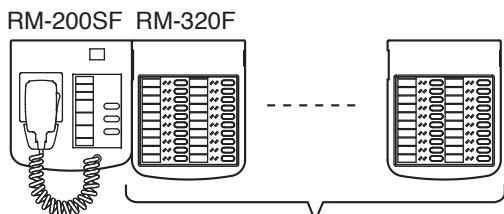

(1) Up to 4 units connectable

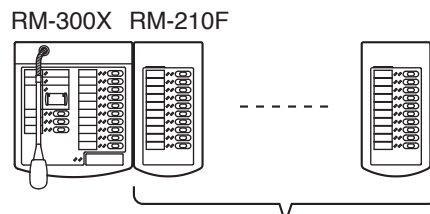

(2) Up to 7 units connectable

Notes

- The number of remote microphones to which power can be supplied from the VX-3000F is limited depending on the configuration of the VX-3000F or remote microphone. (See p. 3-61.)
- The remote microphone to which power cannot be supplied from the VX-3000F needs the power supply from the AD-246 AC adapter, VX-3000DS or VX-3150DS. If the remote microphone is required to be operated even during power failure, power needs to be supplied from the VX-3000DS or VX-3150DS. (See p. 3-61.)

8.3.2. Power supply and limit on the number of remote microphones

The number of remote microphones connectable in a system is as follows.

- Up to 2 RM-200SFs and up to 6 RM-300Xs and RM-500s (8 units in total) can be connected to the VX-3000F.
- Up to 4 RM-320Fs can be connected to the RM-200SF, and up to 7 RM-210Fs to the RM-300X.

The method of power supply to the remote microphones differs depending on the system application and configuration, and also type of remote microphone. In a system configuration, the allowable number of the microphones connected to the VX-3000F may be limited.

[Power supply to the remote microphones]

Note : Red lines are DC power lines. Black lines are other control lines.

- Each of the VX-3000F's RS LINKs A and B is capable of supplying the maximum current of 1 A. Ensure that the total current consumption of the remote microphones to be connected to each RS LINK is 1 A or less. When power is not supplied from an AC adaptor or the VX-3000DS or the VX-3150DS, the number of the remote microphones connectable to each RS link is up to 2 units in combination of the RM-200SF, RM-300X, and RM-500.

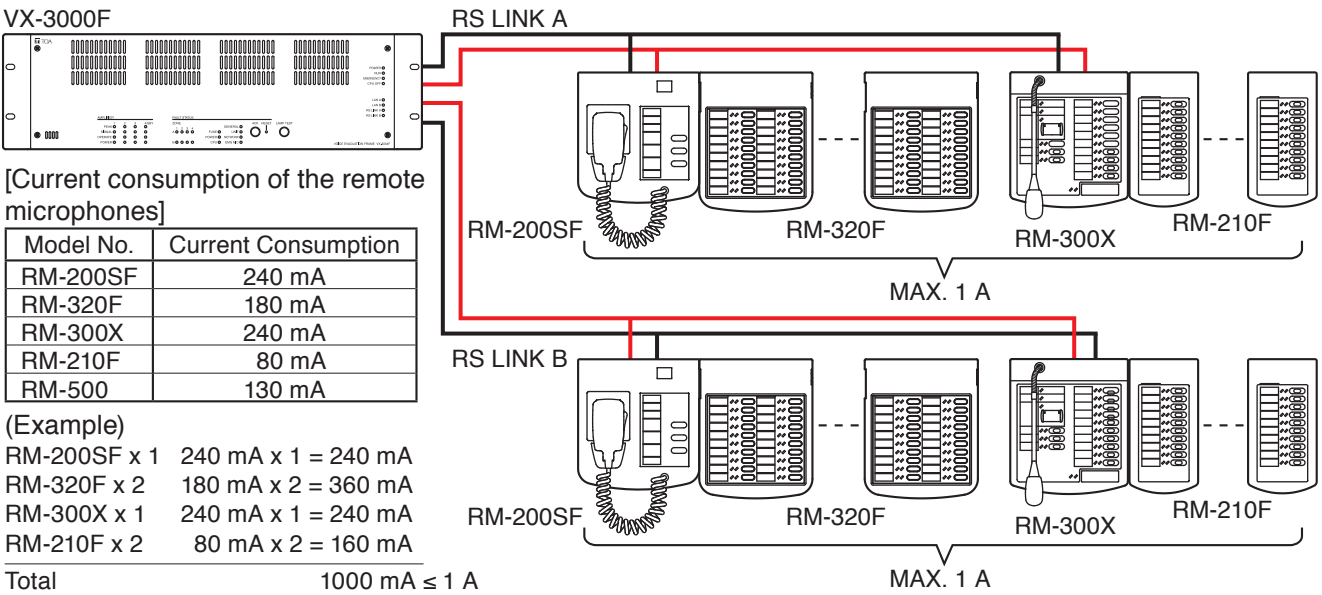

- If the total current consumption of the remote microphones to be connected to each RS LINK exceeds 1 A, the AC adaptor or VX-3000DS or VX-3150DS is additionally required to compensate the power supply for the excessive amount of current.
- If a remote microphone does not need to operate during power failure, the AC adaptor can be used to supply power to it.

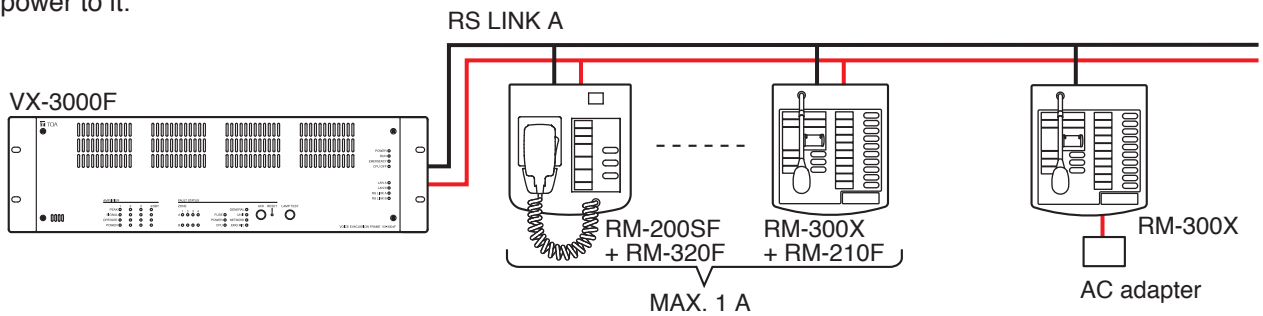

- If a remote microphone needs to operate during power failure, use the VX-3000DS or VX-3150DS to supply power to it.

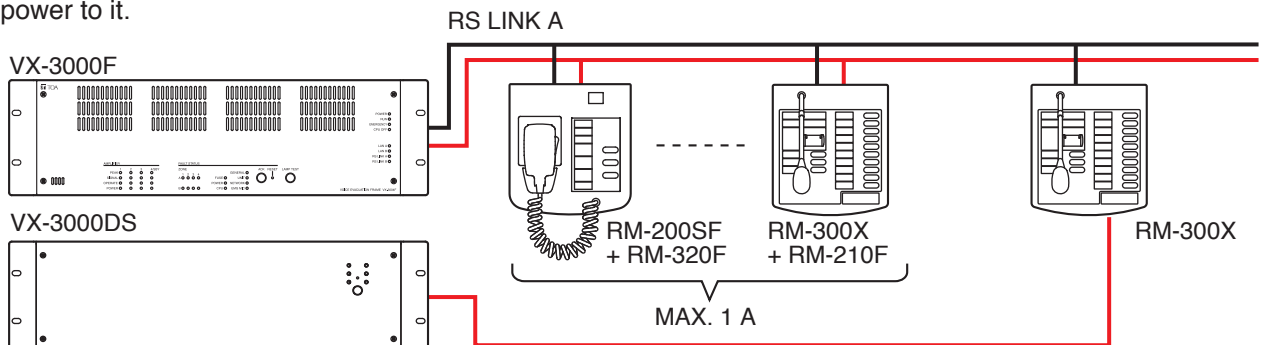

8.3.3. RM-200SF connection

Connect the RM-200SF to either of the RS LINK A or RS LINK B connector of the VX-3000F. The maximum cable distance depends on how power is supplied.

[When power is supplied from the VX-3000F used with the VX-3000DS or the VX-3150DS]

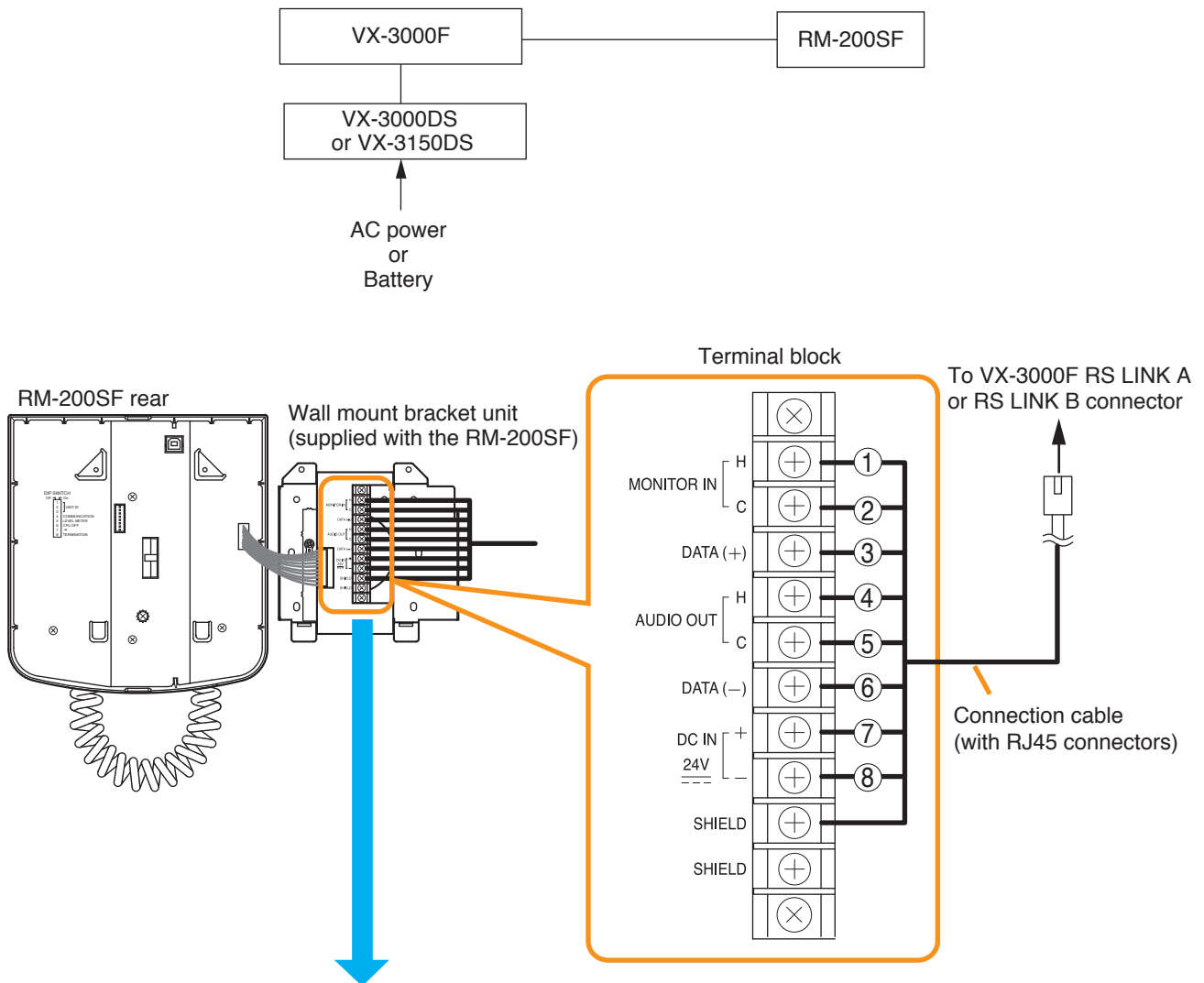

Wall mount bracket unit (supplied with the RM-200SF)	RJ45 connector pin No.	Cable color (T568B type)	Cable color (T568A type)
MONITOR IN (H)	①	Orange/White	Green/White
MONITOR IN (C)	②	Orange	Green
DATA (+)	③	Green/White	Orange/White
AUDIO OUT (H)	④	Blue	Blue
AUDIO OUT (C)	⑤	Blue/White	Blue/White
DATA (-)	⑥	Green	Orange
DC IN 24 V (+)	⑦	Brown/White	Brown/White
DC IN 24 V (-)	⑧	Brown	Brown
SHIELD	Shield	—	—

- When the VX-3000DS or the VX-3150DS is operating on AC power

The following table shows the maximum cable distance when STP Category 5 straight cable (with RJ45 connectors) is used.

Cable \ No. of extension units	RM-200SF alone	RM-200SF + RM-320F x 1	RM-200SF + RM-320F x 2	RM-200SF + RM-320F x 3	RM-200SF + RM-320F x 4
STP Category 5	336 m	191 m	132 m	101 m	81 m

To make longer cable lengths than those shown in the above table, use over 4-pair shielded CPEV cable. The relationship of the CPEV cable conductor diameter to the maximum cable distance is as follows.

Cable \ No. of extension units	RM-200SF alone	RM-200SF + RM-320F x 1	RM-200SF + RM-320F x 2	RM-200SF + RM-320F x 3	RM-200SF + RM-320F x 4
∅0.65 mm	555 m	315 m	219 m	167 m	135 m
∅0.9 mm	1081 m	613 m	426 m	326 m	263 m
∅1.2 mm	1200 m	1086 m	755 m	577 m	465 m

- When the VX-3000DS or the VX-3150DS is operating on battery

The following table shows the maximum cable distance when STP Category 5 straight cable (with RJ45 connectors) is used.

Cable \ No. of extension units	RM-200SF alone	RM-200SF + RM-320F x 1	RM-200SF + RM-320F x 2	RM-200SF + RM-320F x 3	RM-200SF + RM-320F x 4
STP Category 5	92 m	51 m	35 m	26 m	20 m

To make longer cable lengths than those shown in the above table, use over 4-pair shielded CPEV cable. The relationship of the CPEV cable conductor diameter to the maximum cable distance is as follows.

Cable \ No. of extension units	RM-200SF alone	RM-200SF + RM-320F x 1	RM-200SF + RM-320F x 2	RM-200SF + RM-320F x 3	RM-200SF + RM-320F x 4
∅0.65 mm	152 m	85 m	58 m	43 m	34 m
∅0.9 mm	296 m	165 m	112 m	84 m	66 m
∅1.2 mm	524 m	292 m	199 m	149 m	118 m

[When power is supplied from the AC adapter]

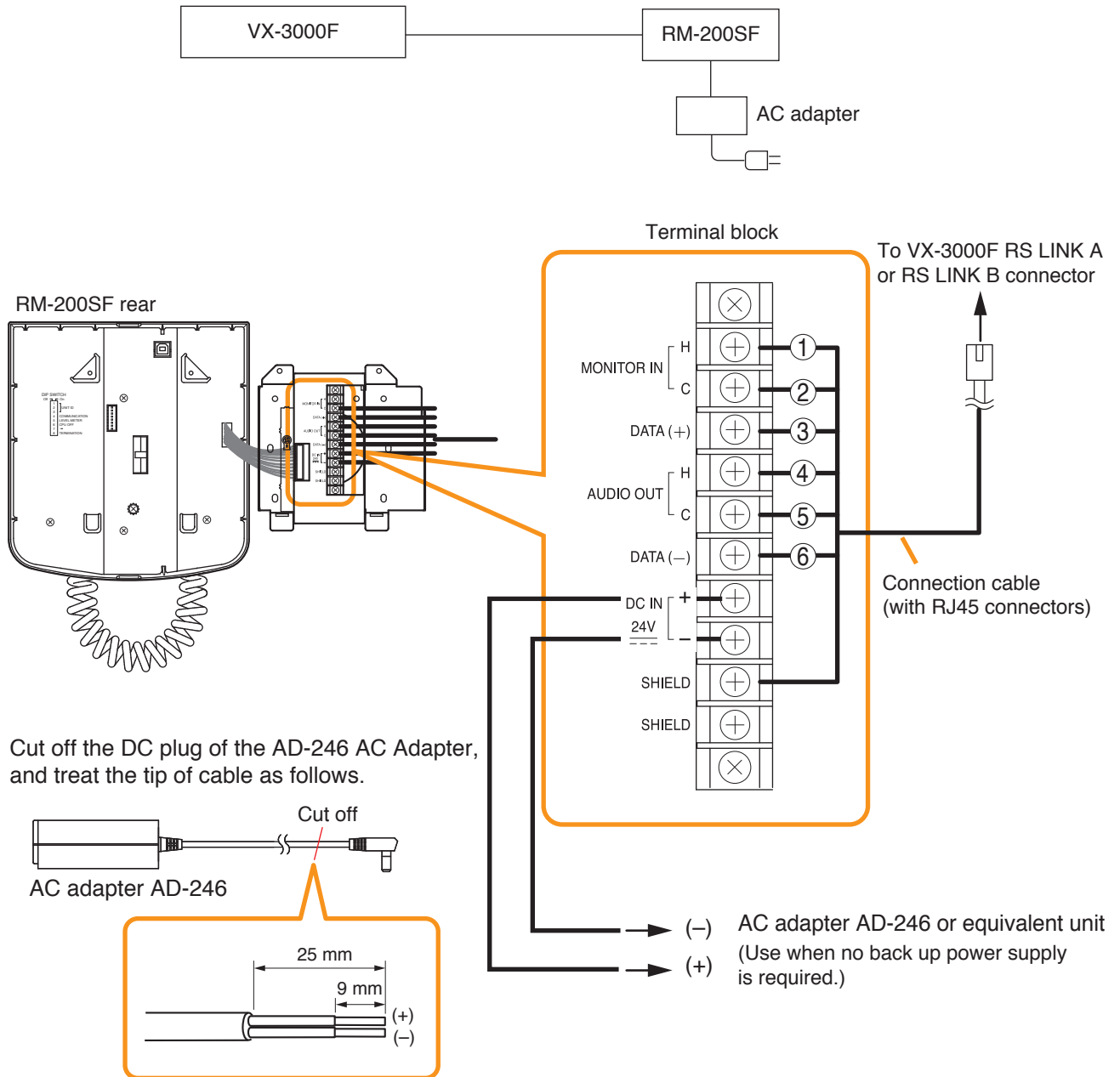

Usable AC adapter: 24 V DC/over 200 mA
(Operation range: 14 – 28 V DC)

When a STP category 5 straight cable or over 4-pair shielded CPEV cable is used as communication cable (excluding power line) between the RM-200SF and the VX-3000F, the maximum cable distance in a system is 1200 m in total.

[When power is supplied from the VX-3000DS or the VX-3150DS]

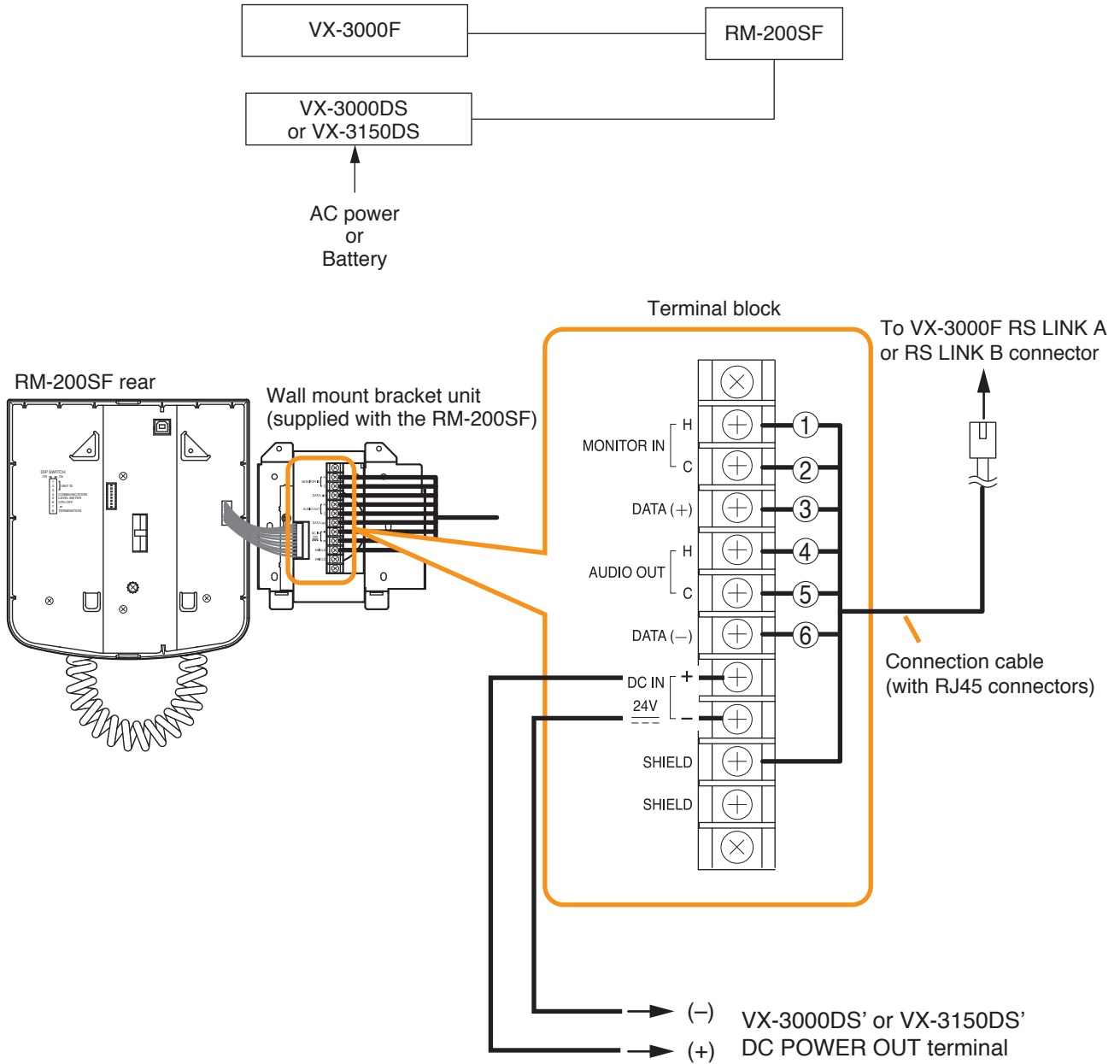

When a STP Category 5 straight cable is used as communication cable (excluding power line) between the RM-200SF and the VX-3000F, the maximum cable distance in a system is 1200 m in total.

- When the VX-3000DS or the VX-3150DS is operating on AC power

The maximum distance of power cable between the RM-200SF and the VX-3000DS or the VX-3150DS is as follows.

The following table shows the maximum cable distance when STP Category 5 straight cable (with RJ45 connectors) is used.

Cable \ No. of extension units	RM-200SF alone	RM-200SF + RM-320F x 1	RM-200SF + RM-320F x 2	RM-200SF + RM-320F x 3	RM-200SF + RM-320F x 4
STP Category 5	355 m	203 m	142 m	109 m	88 m

To make longer cable lengths than those shown in the above table, use over 4-pair shielded CPEV cable. The relationship of the CPEV cable conductor diameter to the maximum cable distance is as follows:

Cable \ No. of extension units	RM-200SF alone	RM-200SF + RM-320F x 1	RM-200SF + RM-320F x 2	RM-200SF + RM-320F x 3	RM-200SF + RM-320F x 4
ø0.65 mm	586 m	335m	234 m	180 m	146 m
ø0.9 mm	1141 m	652 m	456 m	351 m	285 m
ø1.2 mm	1200 m	1154 m	808 m	621 m	505 m

- When the VX-3000DS or the VX-3150DS is operating on battery

The maximum distance of power cable between the RM-200SF and the VX-3000DS or the VX-3150DS is as follows.

The following table shows the maximum cable distance when STP Category 5 straight cable (with RJ45 connectors) is used.

Cable \ No. of extension units	RM-200SF alone	RM-200SF + RM-320F x 1	RM-200SF + RM-320F x 2	RM-200SF + RM-320F x 3	RM-200SF + RM-320F x 4
STP Category 5	111 m	63 m	44 m	34 m	27 m

To make longer cable lengths than those shown in the above table, use over 4-pair shielded CPEV cable. The relationship of the CPEV cable conductor diameter to the maximum cable distance is as follows.

Cable \ No. of extension units	RM-200SF alone	RM-200SF + RM-320F x 1	RM-200SF + RM-320F x 2	RM-200SF + RM-320F x 3	RM-200SF + RM-320F x 4
ø0.65 mm	183 m	104 m	73 m	56 m	45 m
ø0.9 mm	356 m	203 m	142 m	109 m	89 m
ø1.2 mm	631 m	360 m	252 m	194 m	157 m

8.3.4. RM-300X and RM-500 connection

Connect the RM-300X or RM-500 to either of the RS LINK A or RS LINK B connector of the VX-3000F. The maximum cable distance depends on how power is supplied.

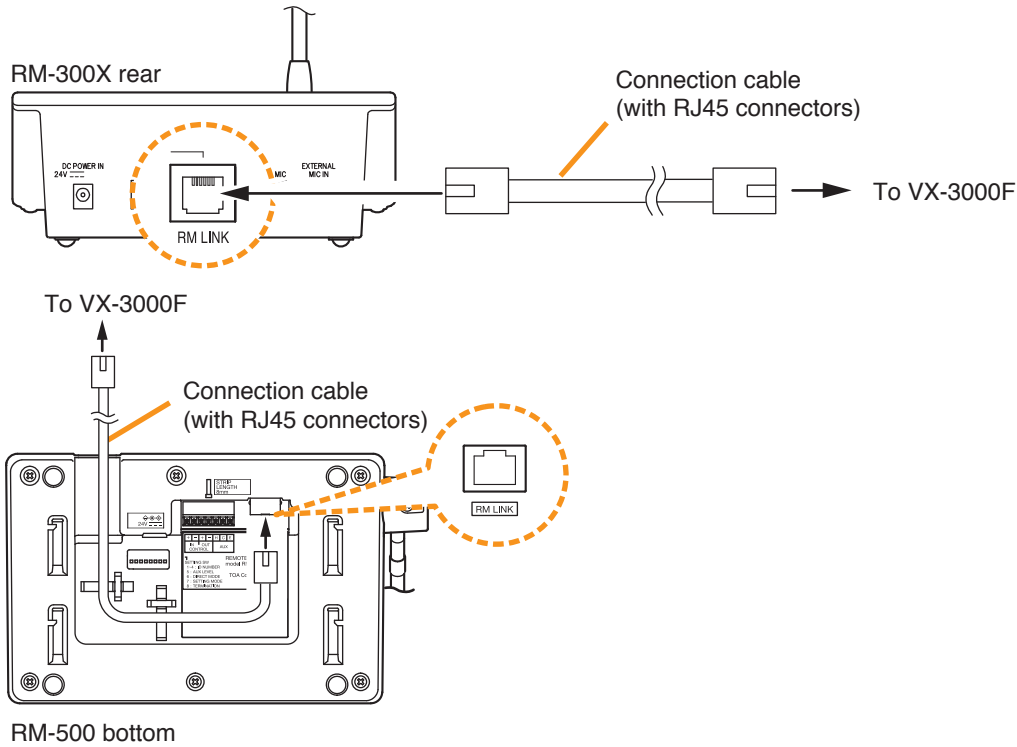

[When power is supplied from the VX-3000F used with the VX-3000DS or the VX-3150DS]

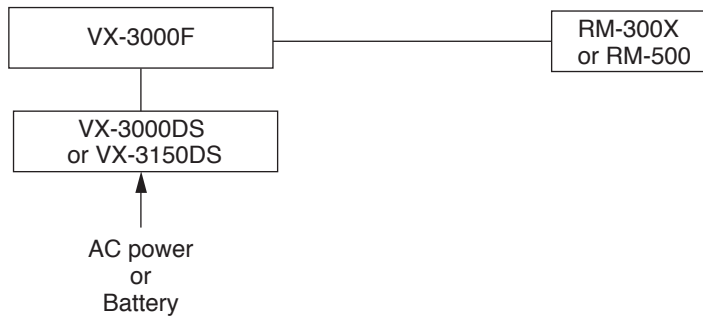

- When VX-3000DS or VX-3150DS is operating on AC power

The following table shows the maximum cable distance when STP Category 5 straight cable (with RJ45 connectors) is used.

[RM-300X]

Cable	No. of extension units	RM-300X alone	RM-300X + RM-210F x 1	RM-300X + RM-210F x 2	RM-300X + RM-210F x 3
		STP Category 5	336 m	251 m	200 m
Cable	No. of extension units	RM-300X + RM-210F x 4	RM-300X + RM-210F x 5	RM-300X + RM-210F x 6	RM-300X + RM-210F x 7
		STP Category 5	142 m	124 m	110 m

[RM-500]

Cable	Unit	RM-500 x 1	RM-500 x 2	RM-500 x 3	RM-500 x 4
STP Category 5		623 m	310 m	206 m	153 m

To make longer cable lengths than those shown in the above table, use over 4-pair shielded CPEV cable. (For the cable connection, see p. 3-70.)

The relationship of the CPEV cable conductor diameter to the maximum cable distance is as follows:

[RM-300X]

Cable \ No. of extension units	RM-300X alone	RM-300X + RM-210F x 1	RM-300X + RM-210F x 2	RM-300X + RM-210F x 3
∅0.65 mm	555 m	415 m	331 m	275 m
∅0.9 mm	1081 m	808 m	644 m	535 m
∅1.2 mm	1200 m	1200 m	1141 m	948 m
Cable \ No. of extension units	RM-300X + RM-210F x 4	RM-300X + RM-210F x 5	RM-300X + RM-210F x 6	RM-300X + RM-210F x 7
∅0.65 mm	235 m	205 m	182 m	163 m
∅0.9 mm	457 m	399 m	354 m	317 m
∅1.2 mm	810 m	707 m	626 m	562 m

[RM-500]

Cable \ Unit	RM-500 x 1	RM-500 x 2	RM-500 x 3	RM-500 x 4
∅0.65 mm	1030 m	512 m	340 m	253 m
∅0.9 mm	1200 m	997 m	661 m	493 m
∅1.2 mm	1200 m	1200 m	1171 m	874 m

- When the VX-3000DS or the VX-3150DS is operating on battery

The following table shows the maximum cable distance when STP Category 5 straight cable (with RJ45 connectors) is used.

[RM-300X]

Cable \ No. of extension units	RM-300X alone	RM-300X + RM-210F x 1	RM-300X + RM-210F x 2	RM-300X + RM-210F x 3
STP Category 5	92 m	68 m	54 m	44 m
Cable \ No. of extension units	RM-300X + RM-210F x 4	RM-300X + RM-210F x 5	RM-300X + RM-210F x 6	RM-300X + RM-210F x 7
STP Category 5	37 m	32 m	28 m	25 m

[RM-500]

Cable \ Unit	RM-500 x 1	RM-500 x 2	RM-500 x 3	RM-500 x 4
STP Category 5	172 m	84 m	55 m	41 m

To make longer cable lengths than those shown in the above table, use over 4-pair shielded CPEV cable. (For the cable connection, see p. 3-70.)

The relationship of the CPEV cable conductor diameter to the maximum cable distance is as follows:

[RM-300X]

Cable \ No. of extension units	RM-300X alone	RM-300X + RM-210F x 1	RM-300X + RM-210F x 2	RM-300X + RM-210F x 3
∅0.65 mm	152 m	113 m	89 m	73 m
∅0.9 mm	296 m	220 m	174 m	143 m
∅1.2 mm	524 m	389 m	308 m	253 m
Cable \ No. of extension units	RM-300X + RM-210F x 4	RM-300X + RM-210F x 5	RM-300X + RM-210F x 6	RM-300X + RM-210F x 7
∅0.65 mm	62 m	54 m	47 m	42 m
∅0.9 mm	121 m	105 m	92 m	82 m
∅1.2 mm	215 m	186 m	163 m	145 m

[RM-500]

Cable \ Unit	RM-500 x 1	RM-500 x 2	RM-500 x 3	RM-500 x 4
∅0.65 mm	285 m	140 m	91 m	67 m
∅0.9 mm	555 m	272 m	178 m	131 m
∅1.2 mm	983 m	483 m	316 m	233 m

Tips

- When using a shielded CPEV cable, it is recommended to use an optional RM-200RJ Terminal Unit that serves wiring conversion between the CPEV cable and STP Category 5 straight cable (with RJ45 connectors). Connect the CPEV cable between the same terminals of both RM-200RJ units pairing cables 1 with 2, 4 with 5, 3 with 6, and 7 with 8 as shown below.

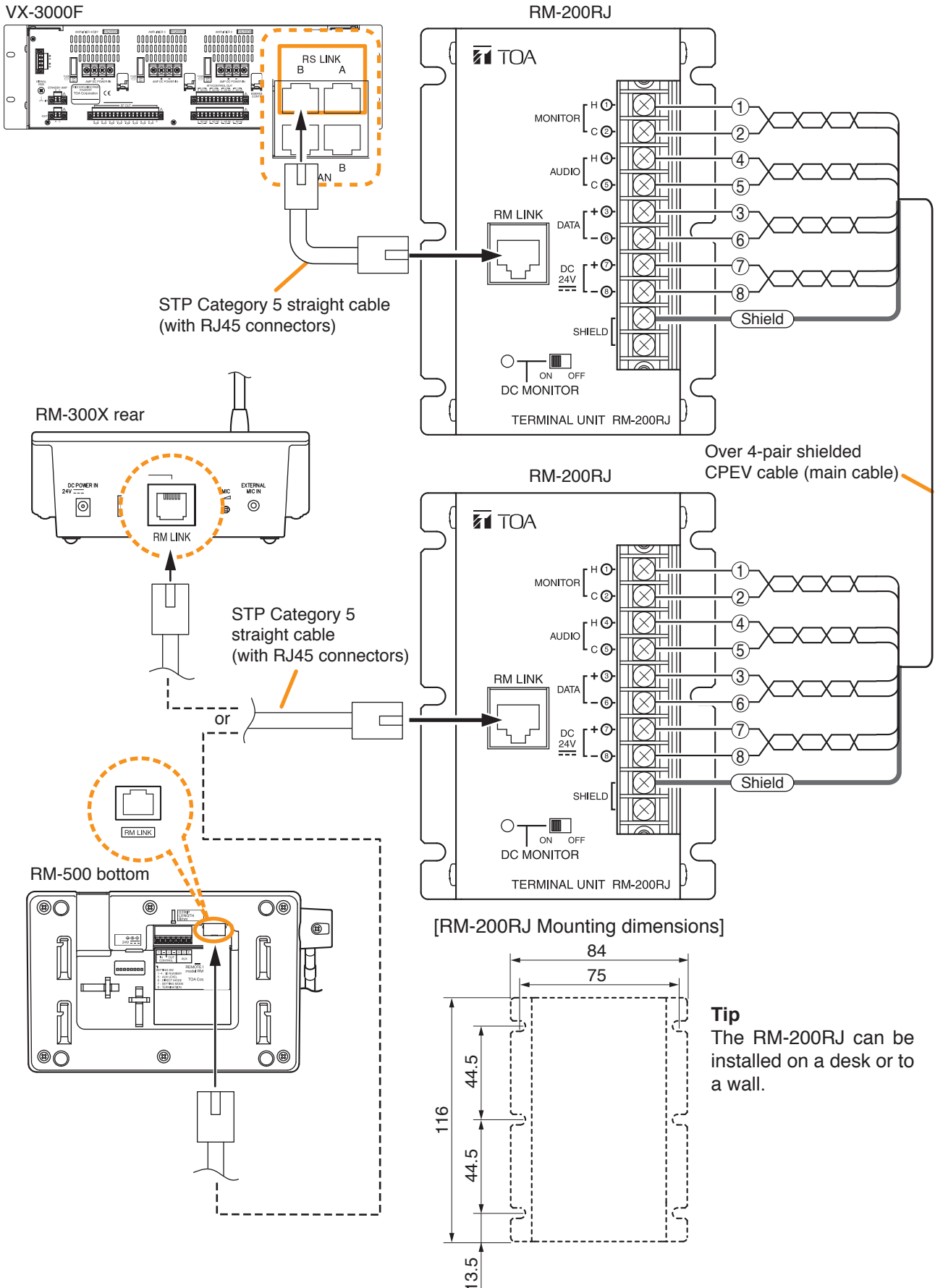

- When using a shielded CPEV cable but not the RM-200RJ, connect the cable to STP Category 5 straight cable (with RJ45 connectors) as follows.
Pair 1 with 2, 3 with 6, 4 with 5, and 7 with 8.

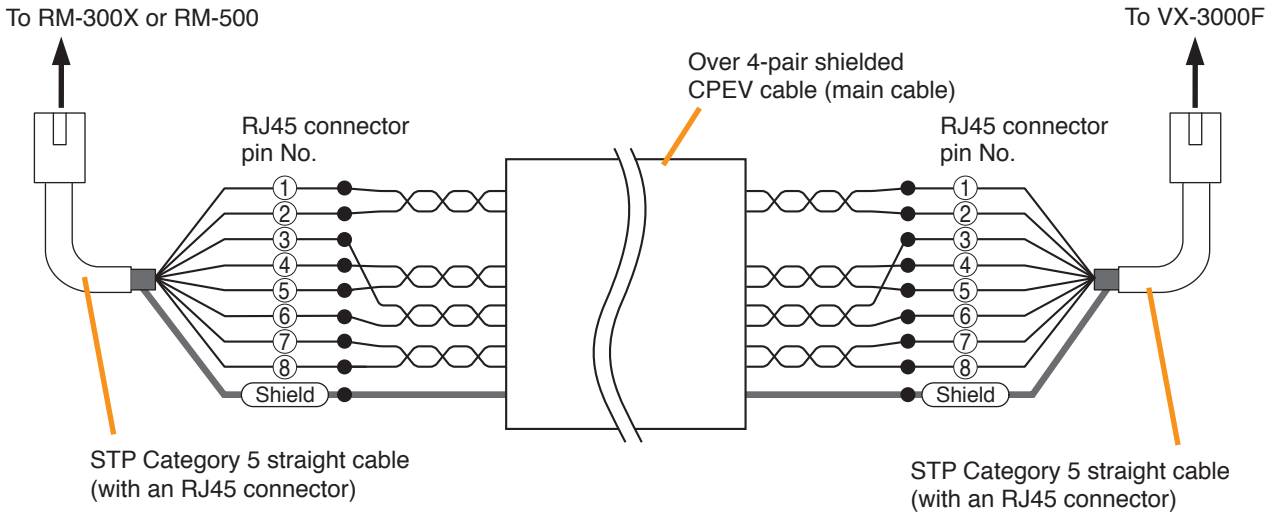

RM-300X or RM-500	RJ45 connector pin No.	Cable color (T568B type)	Cable color (T568A type)	VX-3000F
Monitor in (H)	①	Orange/White	Green/White	Monitor out (H)
Monitor in (C)	②	Orange	Green	Monitor out (C)
RM data (+)	③	Green/White	Orange/White	RM data (+)
Audio out (H)	④	Blue	Blue	Audio in (H)
Audio out (C)	⑤	Blue/White	Blue/White	Audio in (C)
RM data (-)	⑥	Green	Orange	RM data (-)
DC power in (+)	⑦	Brown/White	Brown/White	DC power out (+)
DC power in (-)	⑧	Brown	Brown	DC power out (-)
Shield	Shield	—	—	Shield

[When power is supplied from the AC adapter]



When supplying power to the RM-300X or RM-500 from the optional AD-246 AC Adapter using an STP category 5 straight cable or over 4-pair shielded CPEV cable, the maximum length of connection cable (excluding power line) is 1200 m regardless of the type of cable and the number of remote microphone extension units.

Note

To power the remote microphones even during power failures, a battery backup is also needed for the AC adapter.

Or supply power to the remote microphones from the VX-3000DS or the VX-3150DS without using the AC adapter.

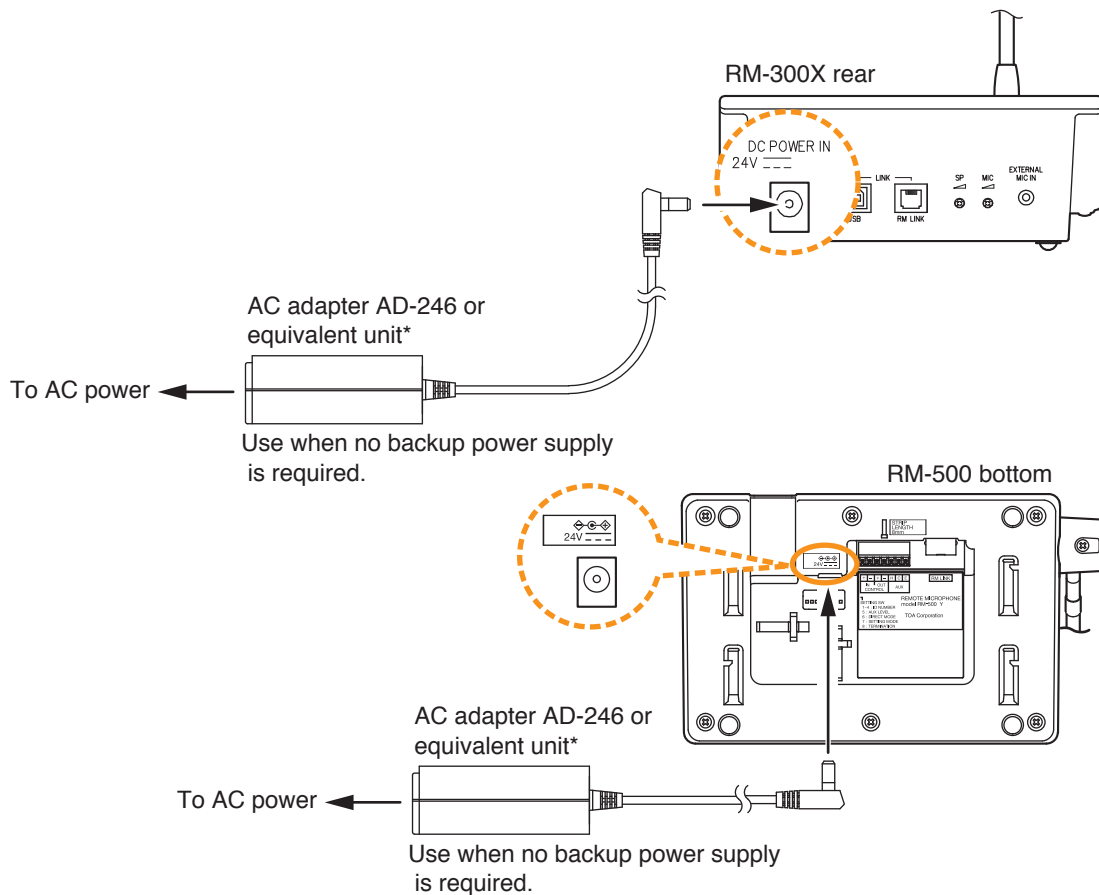

- * Usable AC adapter
 24 V DC/over 200 mA (Operation range: 14 – 28 V DC)
 Usable power output plug: Non-polarity type (Any polarity can be used.)
 (5.5 mm outer diameter, 2.1 mm inner diameter, and 9.5 mm long)

Notes

- Plugging a DC plug into the RM-300X's or RM-500's power input terminal automatically switches the RM-300X's or RM-500's DC power input to this terminal, disconnecting the unit's power supply from the RM link connector.
- If the DC plug is pulled out, the RM link connector takes over the unit's power supply and is connected to the system power line. This may cause the voltage drop of power supply and increase the current consumption from the VX-3000F, resulting in the system malfunction.
- Regarding the RM-300X, be sure to firmly secure the DC plug by fixing the power cable onto the RM-300X's bottom-mounted cable hook.

[When power is supplied from the VX-3000DS or the VX-3150DS]

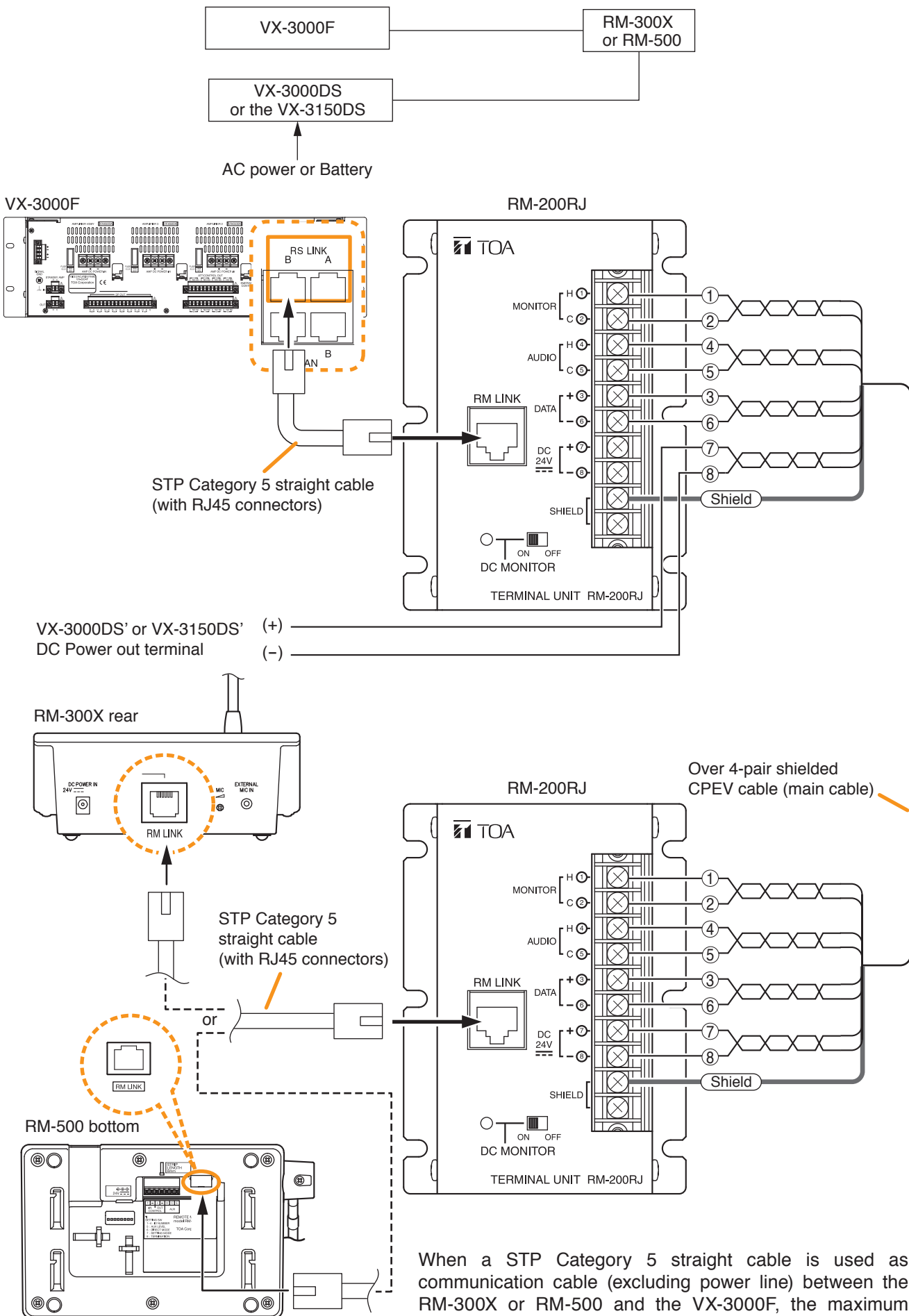

When a STP Category 5 straight cable is used as communication cable (excluding power line) between the RM-300X or RM-500 and the VX-3000F, the maximum cable distance in a system is 1200 m in total.

- When the VX-3000DS or the VX-3150DS is operating on AC power

The maximum distance of power cable between the RM-300X or RM-500 and the VX-3000DS or the VX-3150DS is as follows.

The following table shows the maximum cable distance when STP Category 5 straight cable (with RJ45 connectors) is used.

[RM-300X]

Cable \ No. of extension units	RM-300X alone	RM-300X + RM-210F x 1	RM-300X + RM-210F x 2	RM-300X + RM-210F x 3
STP Category 5	355 m	266 m	213 m	177 m
Cable \ No. of extension units	RM-300X + RM-210F x 4	RM-300X + RM-210F x 5	RM-300X + RM-210F x 6	RM-300X + RM-210F x 7
STP Category 5	152 m	133 m	118 m	106 m

[RM-500]

Cable \ Unit	RM-500 x 1	RM-500 x 2	RM-500 x 3	RM-500 x 4
STP Category 5	656 m	328 m	218 m	164 m

To make longer cable lengths than those shown in the above table, use over 4-pair shielded CPEV cable. (For the cable connection, see [p. 3-70](#).)

The relationship of the CPEV cable conductor diameter to the maximum cable distance is as follows:

[RM-300X]

Cable \ No. of extension units	RM-300X alone	RM-300X + RM-210F x 1	RM-300X + RM-210F x 2	RM-300X + RM-210F x 3
∅0.65 mm	586 m	440 m	352 m	293 m
∅0.9 mm	1141 m	856 m	684 m	570 m
∅1.2 mm	1200 m	1200 m	1200 m	1010 m
Cable \ No. of extension units	RM-300X + RM-210F x 4	RM-300X + RM-210F x 5	RM-300X + RM-210F x 6	RM-300X + RM-210F x 7
∅0.65 mm	251 m	220 m	195 m	176 m
∅0.9 mm	489 m	428 m	380 m	342 m
∅1.2 mm	865 m	757 m	673 m	606 m

[RM-500]

Cable \ Unit	RM-500 x 1	RM-500 x 2	RM-500 x 3	RM-500 x 4
∅0.65 mm	1083 m	541 m	361 m	270 m
∅0.9 mm	1200 m	1053 m	702 m	526 m
∅1.2 mm	1200 m	1200 m	1200 m	932 m

- When the VX-3000DS or the VX-3150DS is operating on battery

The maximum distance of power cable between the RM-300X or RM-500 and the VX-3000DS or the VX-3150DS is as follows.

The following table shows the maximum cable distance when STP Category 5 straight cable (with RJ45 connectors) is used.

[RM-300X]

Cable \ No. of extension units	RM-300X alone	RM-300X + RM-210F x 1	RM-300X + RM-210F x 2	RM-300X + RM-210F x 3
STP Category 5	111 m	83 m	66 m	55 m
Cable \ No. of extension units	RM-300X + RM-210F x 4	RM-300X + RM-210F x 5	RM-300X + RM-210F x 6	RM-300X + RM-210F x 7
STP Category 5	47 m	41 m	37 m	33 m

[RM-500]

Cable \ Unit	RM-500 x 1	RM-500 x 2	RM-500 x 3	RM-500 x 4
STP Category 5	205 m	102 m	68 m	51 m

To make longer cable lengths than those shown in the above table, use over 4-pair shielded CPEV cable. (For the cable connection, see p. 3-70.)

The relationship of the CPEV cable conductor diameter to the maximum cable distance is as follows:

[RM-300X]

Cable \ No. of extension units	RM-300X alone	RM-300X + RM-210F x 1	RM-300X + RM-210F x 2	RM-300X + RM-210F x 3
∅0.65 mm	183 m	137 m	110 m	91 m
∅0.9 mm	356 m	267 m	214 m	178 m
∅1.2 mm	631 m	473 m	378 m	315 m
Cable \ No. of extension units	RM-300X + RM-210F x 4	RM-300X + RM-210F x 5	RM-300X + RM-210F x 6	RM-300X + RM-210F x 7
∅0.65 mm	78 m	68 m	61 m	55 m
∅0.9 mm	152 m	133 m	118 m	107 m
∅1.2 mm	270 m	236 m	210 m	189 m

[RM-500]

Cable \ Unit	RM-500 x 1	RM-500 x 2	RM-500 x 3	RM-500 x 4
∅0.65 mm	338 m	169 m	112 m	84 m
∅0.9 mm	658 m	329 m	219 m	164 m
∅1.2 mm	1165 m	582 m	388 m	291 m

8.3.5. Connecting other input equipment

Connect microphones or other sound sources with audio inputs using 2-core shielded cables. Four input channels (1 through 4) are provided for the AUDIO INPUT. Use the VX-3000 Setting Software to set their volume, purpose, and type, etc. (See the separate Setting Software Instructions, "Unit configuration setting.")

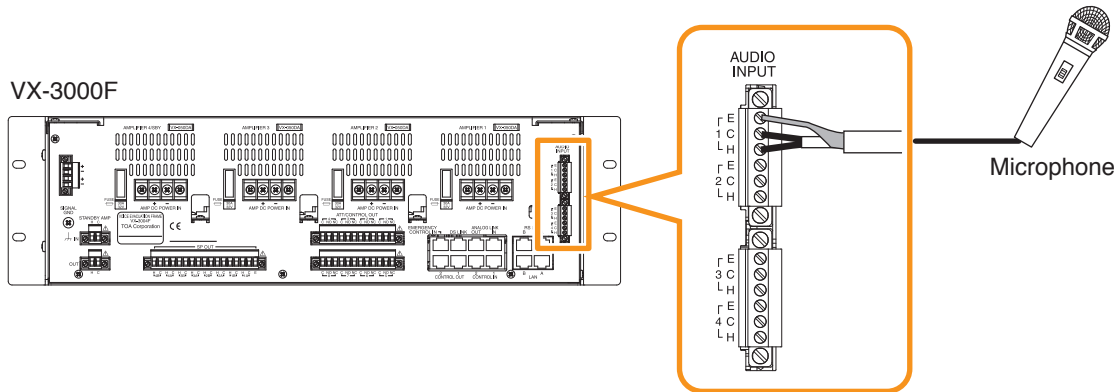

[When using the ANC function]

Connect a sensor microphone when using the ANC function. The ANC setting applies to a single or multiple Audio output channel numbers within the preset unit. You need to perform settings for ANC function using the VX-3000 Setting Software.

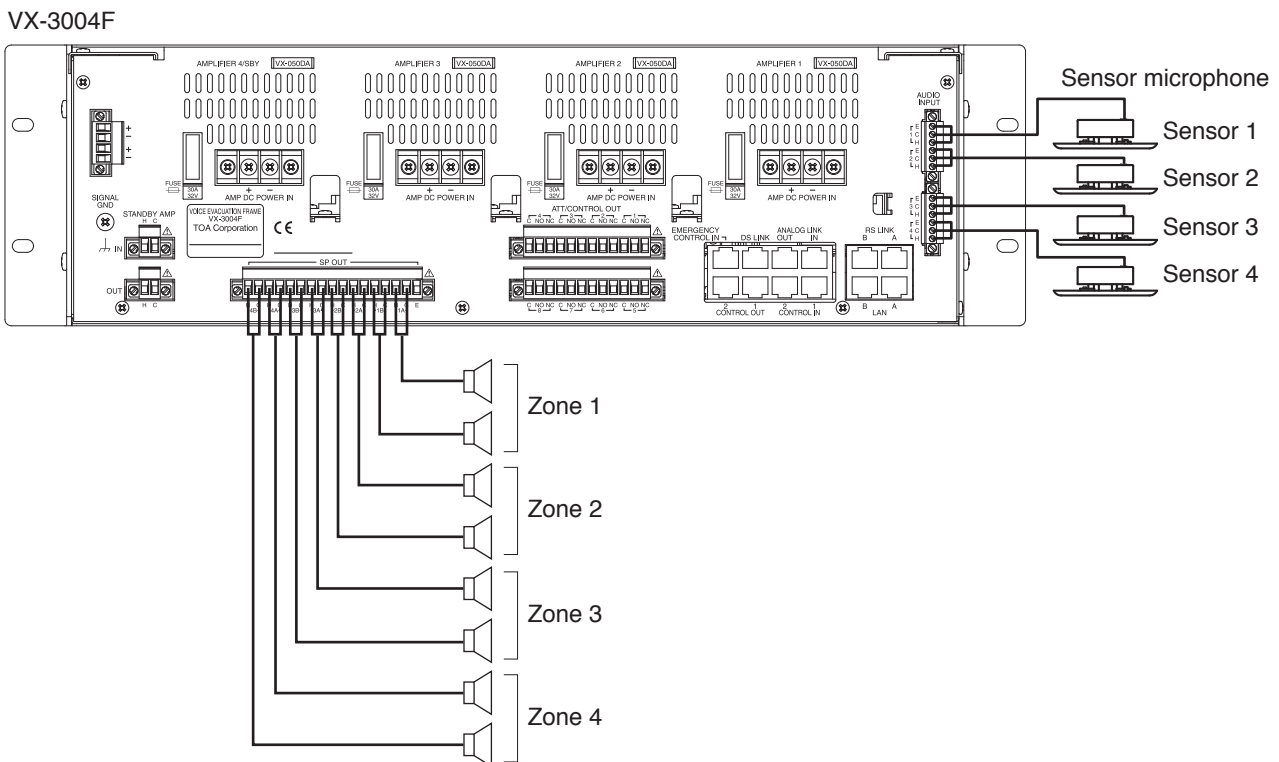

In addition, you need to perform work and settings for sound output at the installation site after completing the device connections.

For details, see the separate Setting Software Instructions, "ANC Function."

8.4. Speaker Connection

Connect speakers to the speaker output terminal.

Following 3 types of wiring systems are available: 2-wire system where no attenuator is connected, and 3-wire and 4-wire systems where attenuators are connected.

Failure detection is available if the EOL unit is connected.

Set the use of attenuator and EOL unit on the VX-3000 Setting Software.

(See the separate Setting Software Instructions, "Unit configuration setting.")

Note

When using Ch4 of the VX-3004F as a standby amplifier, never connect speakers to the speaker output terminals 4A and 4B.

8.4.1. 2-wire system connection

VX-3000F

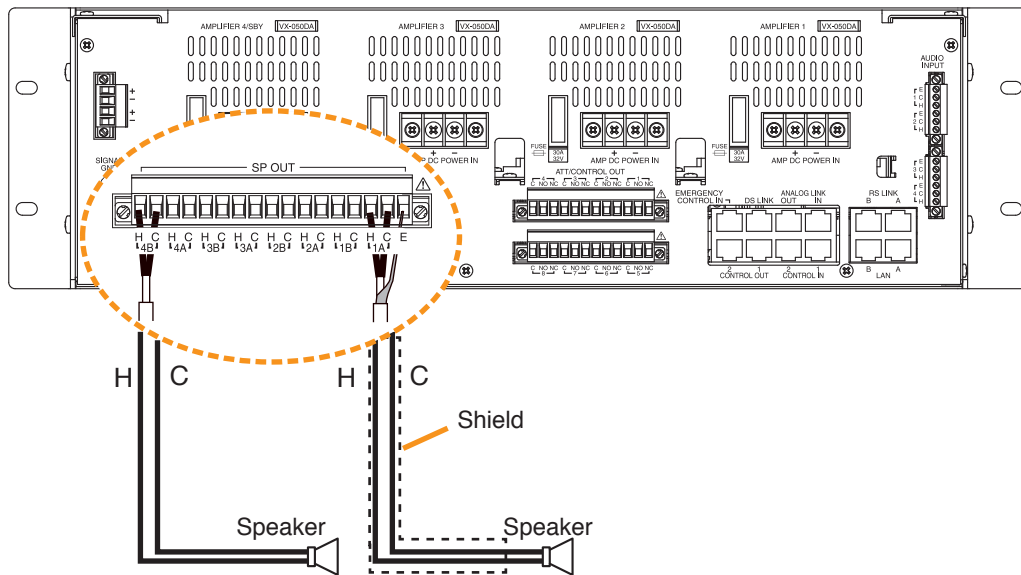

8.4.2. 3-wire system connection

VX-3000F

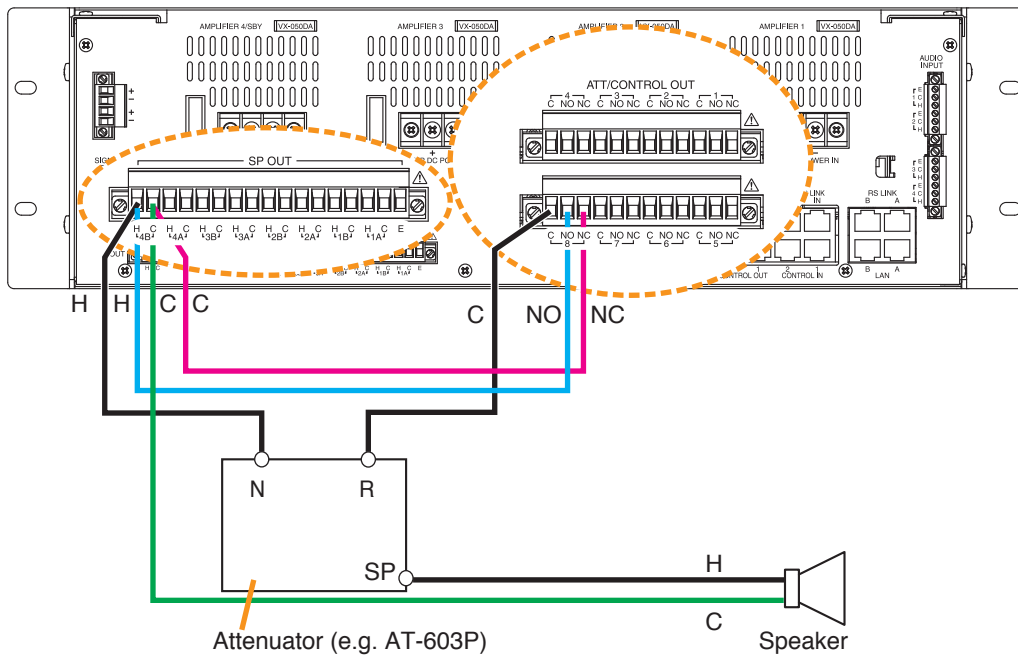

Note

When initializing the surveillance settings, the total speaker wattage per line should be 20 W (500 Ω) or more. Lighter speaker load may cause false detection.

8.4.3. 4-wire system connection

Two types of attenuators are connectable to this unit, one to be bypassed when 24 V DC is applied to the attenuator, and the other to be bypassed when the 24 V DC being normally applied to is cut off (in no voltage mode). Connections of the unit's attenuator control output and 24 V DC power supply's terminals differ depending on the types as shown below.

[Example 1]

Bypassed when 24 V DC is applied to the attenuator.

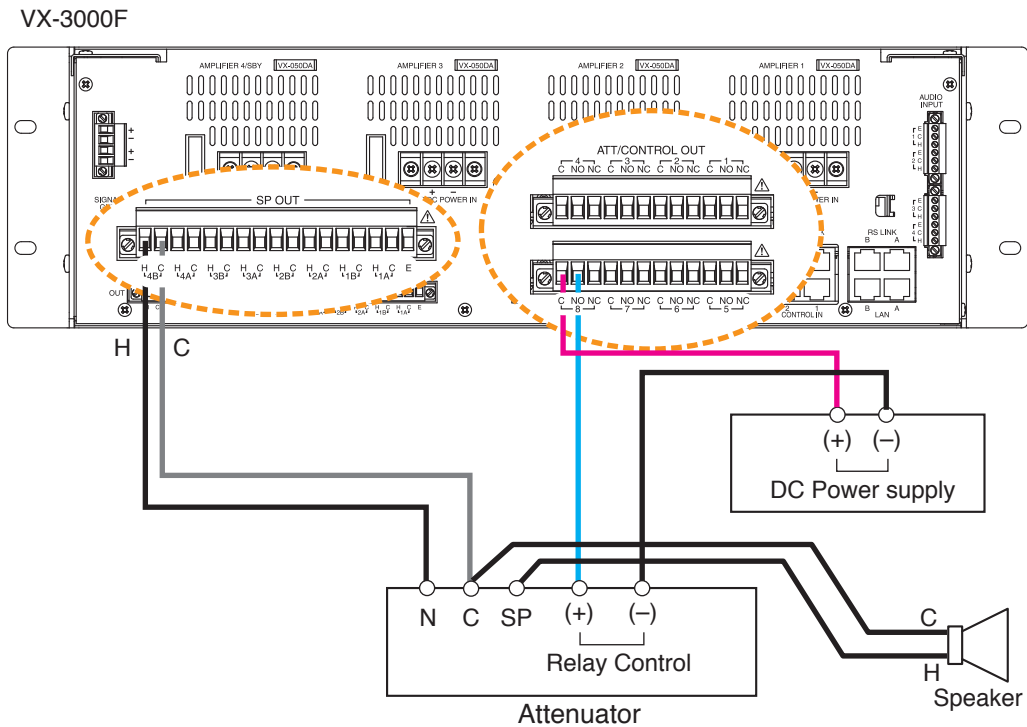

[Example 2]

Bypassed when the 24 V DC being normally applied to is cut off.

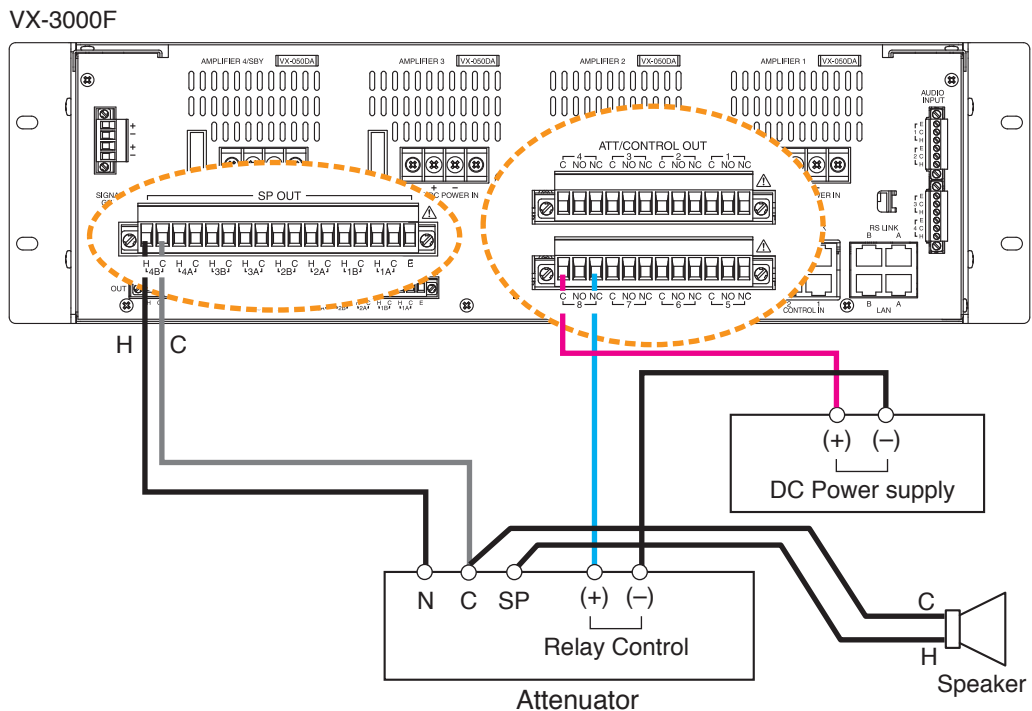

Note

The system in **Example 2** is more fail-safe than that in **Example 1**.

8.4.4. End of line

Speaker line failure can be detected with greater accuracy when the end of line units are connected. Use the SX-200EL for the VX-3004F unit and the VM-300SV for the VX-3008F and VX-3016F units.

[Example 1]

The figure below shows a connection example to connect the SX-200EL to the speaker line.

VX-3004F

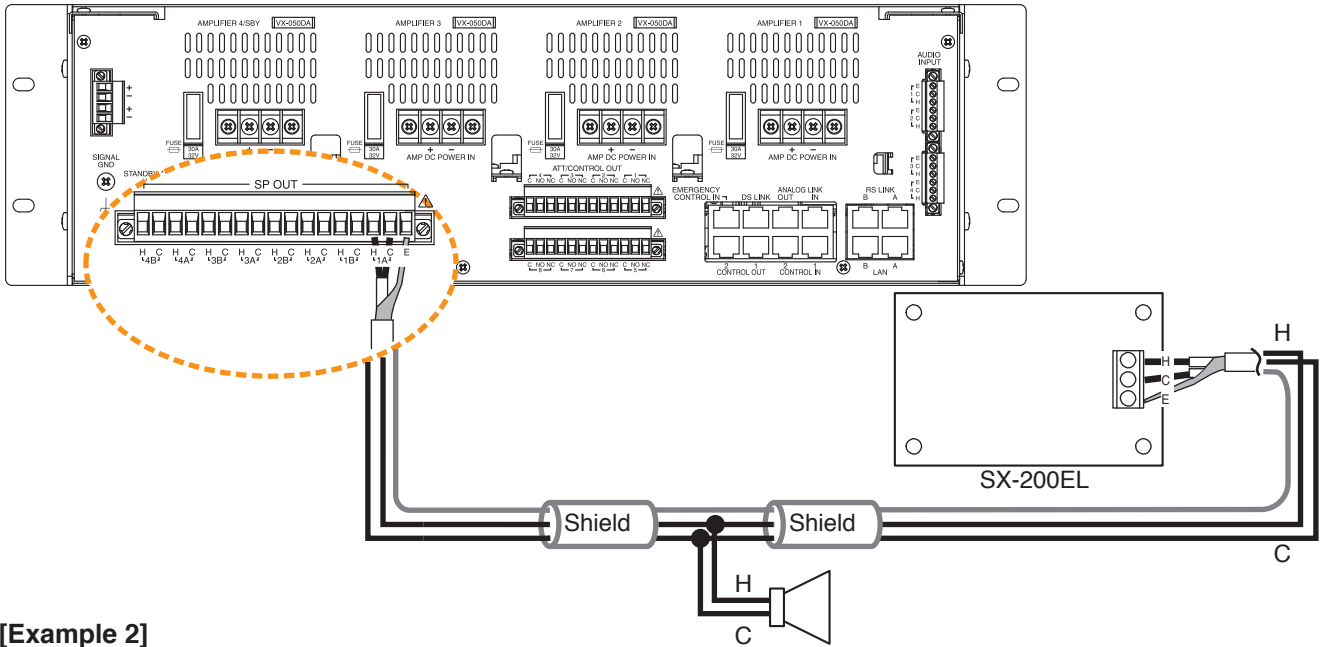

[Example 2]

The figure below shows a connection example to connect the VM-300SV to the speaker line.

Notes

- Connect the VM-300SV between each speaker line end and the unit's control input terminal.
- While a broadcast is being made through the speaker line with the VM-300SV installed, speaker line failure function for that line cannot be performed.
- External attenuators cannot be used in the system with the VM-300SV installed.

VX-3008F

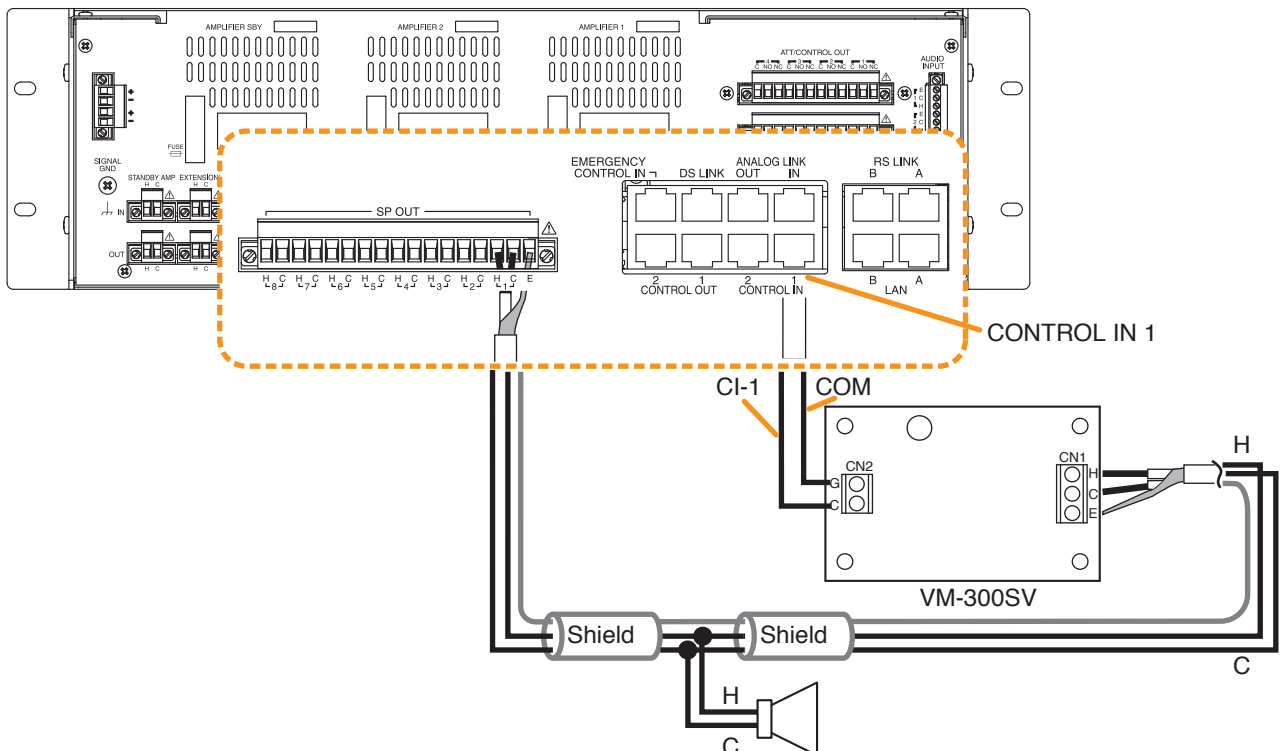

8.5. Control Output Terminal Connections

These terminals provide control outputs.
Control signals (make contact) are output in synchronization with unit operation.

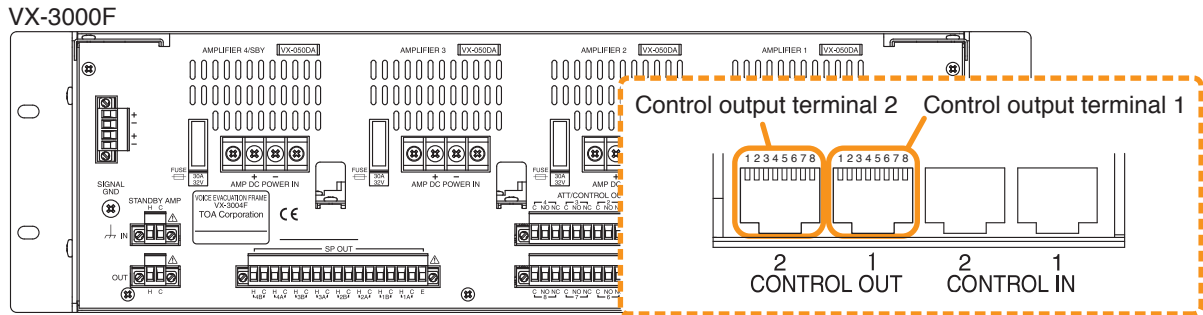

The RJ45's pin arrangement and pin functions are shown below.

[Control output terminal 1]

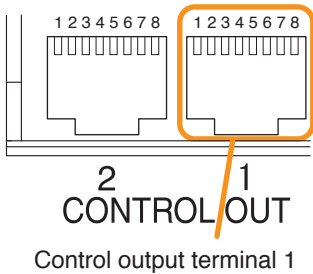

• VX-3004F/3008F

Pin1	Pin2	Pin3	Pin4	Pin5	Pin6	Pin7	Pin8	Shield
CO_9	CO_10	CO_11	CO_12	CO_13	CO_14	CO_15	CO_16	Com
NO	NO	NO	NO	NO	NO	NO	NO	—

• VX-3016F

Pin1	Pin2	Pin3	Pin4	Pin5	Pin6	Pin7	Pin8	Shield
CO_17	CO_18	CO_19	CO_20	CO_21	CO_22	CO_23	CO_24	Com
NO	NO	NO	NO	NO	NO	NO	NO	—

Use the VX-3000 Setting Software to set applications. (See the separate Setting Software Instructions, "Unit configuration setting," "Control Output Pattern Settings.")

[Control output terminal 2]

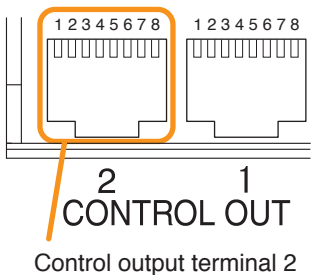

Pin1	Pin2	Pin3	Pin4	Pin5	Pin6	Pin7	Pin8	Shield
GENERAL FAULT	CPU FAULT	CPU OFF	NC	NC	NC	NC	NC	Com
NO	NO	NO	NO	NO	NO	NO	NO	—

- GENERAL FAULT: [In the case of the VX-3000F set to ID "0"]
Outputs a make contact when any one of the VX-3000Fs within the VX-3000 system detects abnormality.
Outputs a make contact when set to CPU off state by the remote microphone.
- [In the case of the VX-3000F set to ID other than "0"]
Remains open (break contact) irrespective of the system status.
- CPU FAULT: Outputs a make contact when CPU error occurs.
- CPU OFF: Outputs a make contact when set to CPU off state by the remote microphone.

8.6. Control Input Terminal Connections

The control input terminals are non-voltage contact inputs. Cable disconnection and short-circuit can be detected using these input terminals.

Set the function, polarity, and failure detection using the VX-3000 Setting Software.

(See the separate Setting Software Instructions, "SURVEILLANCE SETTINGS," "Failure Pattern Settings," "Control Inputs Event Settings.")

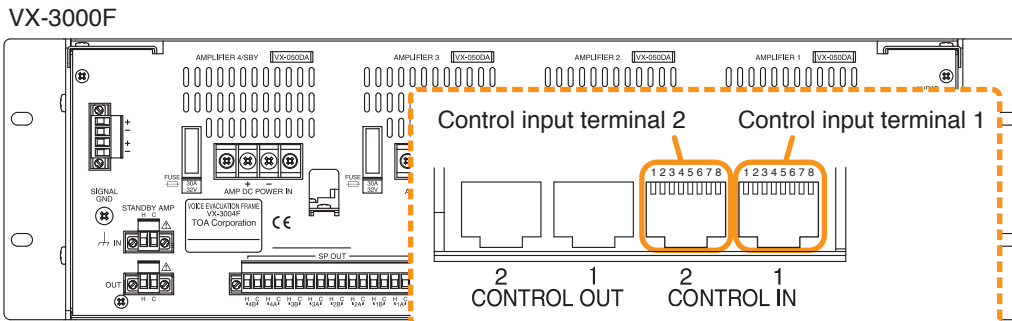

The RJ45's pin arrangement and pin functions are shown below.

[Control input terminal 1]

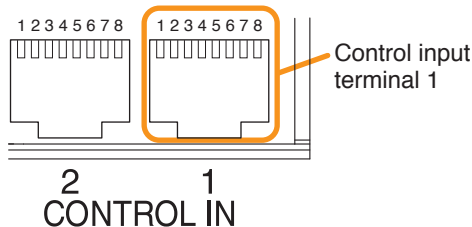

Pin1	Pin2	Pin3	Pin4	Pin5	Pin6	Pin7	Pin8	Shield
CI_1	CI_2	CI_3	CI_4	CI_5	CI_6	CI_7	CI_8	Com

[Control input terminal 2]

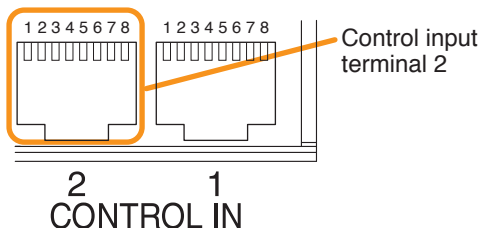

Pin1	Pin2	Pin3	Pin4	Pin5	Pin6	Pin7	Pin8	Shield
CI_9	CI_10	CI_11	CI_12	CI_13	CI_14	CI_15	CI_16	Com

Connection when no failure detection is required

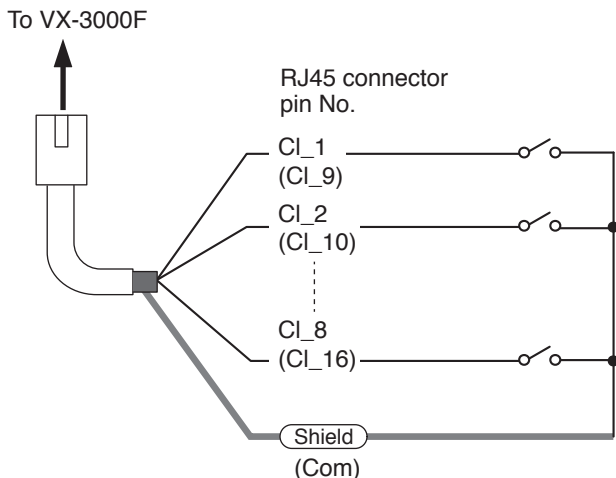

Connection when failure detection is required

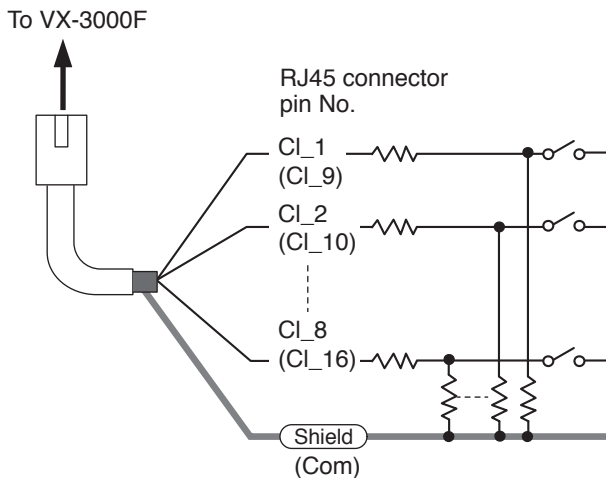

⎓ : All resistor values are 4.7 kΩ. Connect these resistors near the switch.

Note

When connecting the VM-300SV to detect failures such as cable disconnection, you need not connect any resistors as they are connected inside the VM-300SV.

8.7. Emergency Control Input Terminal Connections

The Emergency control input terminals are voltage inputs. Cable disconnection and short-circuit can be detected using these input terminals. Use the VX-3000 Setting Software to set the function and polarity. (See the separate Setting Software Instructions, "SURVEILLANCE SETTINGS," "Failure Pattern Settings," "Control Inputs Event Settings.")

VX-3000F

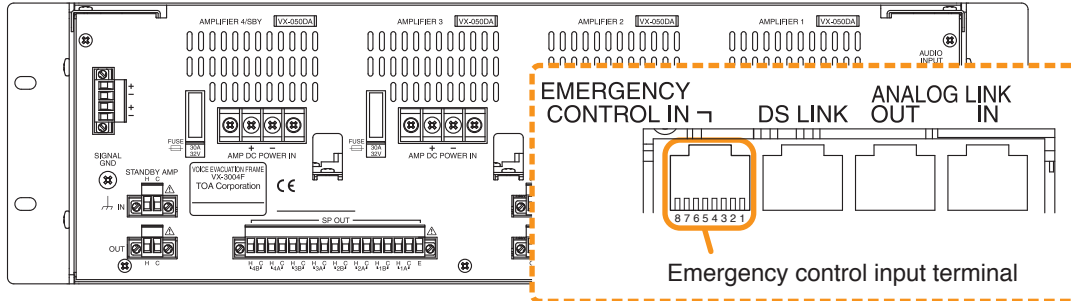

The RJ45's pin arrangement and pin functions are shown below.

[Emergency control input terminal]

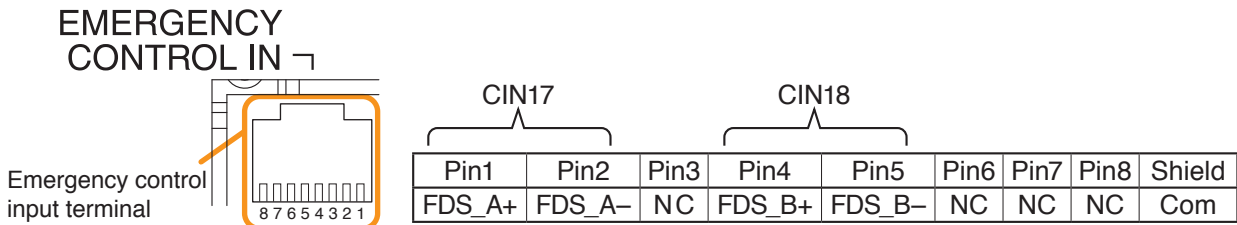

Connection example A

To VX-3000F

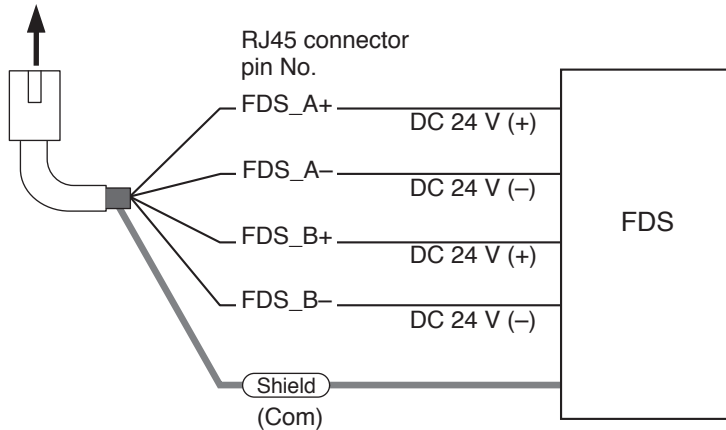

Connection example B

To VX-3000F

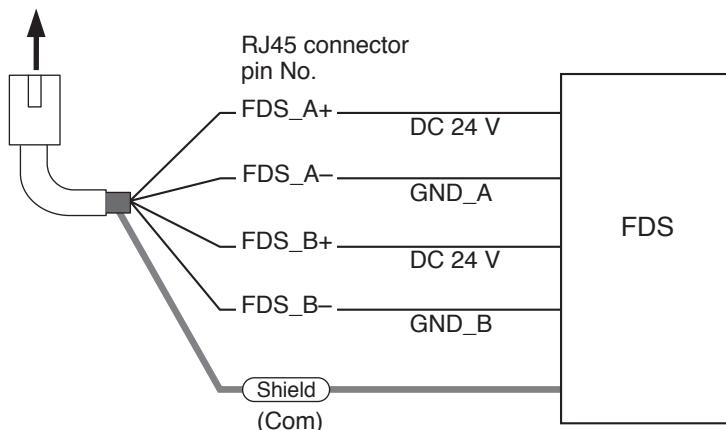

Note
When Connection example B is selected, set the Surveillance function corresponding to the CIN17 (Pins 1 and 2) or CIN18 (Pins 4 and 5) to OFF. (See the separate Setting Software Instructions, "SURVEILLANCE SETTINGS.")

8.8. VX-3000 Unit's LAN Link Connector Connection

8.8.1. LAN Link Connector Connection

Connect the LAN link connectors of all VX-3000 units within the system to each other via switching hubs. Connect each of LAN link connectors A and B to the same switching hub or different switching hubs connected in star configuration.

Also, since the VX-3000F has a HUB function compatible with RSTP (Rapid Spanning Tree Protocol), loop connection is allowed between the VX-3000F units without the use of switching hubs.

Notes

- When non-RSTP-compliant switching hubs are used, increasing the number of the VX-3000 units causes a packet loop to occur among the switching hubs until the VX-3000F begins to execute the loop detection, possibly resulting in connection failure. The use of an RSTP-compliant switching hub is highly recommended.
- Connecting the VX-3000 units to an unstable network where a packet loss may occur possibly results in unexpected system reboot, broadcast status discrepancy between action and consequence, or unstable operation.
- Make the LAN link connectors completely independent from other LAN.
- Only the audio input to the VX-3000PM can be transmitted to other network areas via a router by unicast. Establish a dedicated line using a VPN and the like.
- Be sure to use UTP or STP Category 5 straight cable (with R45 connectors) for connecting LAN link connectors. However, it is recommended to use STP Category 5 straight cable if the cable connection distance is long.
- The distance between each of VX-3000 unit and a switching hub, and between switching hubs is less than 100 m.
- When making a redundant configuration, use both the terminals A and B for connections. If not required, use only the terminal A.
- When making a redundant configuration in the systems that include the VX-3000CT or the VX-3000PM, use the RSTP-compliant switching hubs.
- When connecting the VX-3000CT or the VX-3000PM without using the RSTP-compliant switching hubs, connect only the LAN terminal A.
- When making the VX-3000F in a redundant configuration without using the RSTP-compliant switching hubs, use the switching hub that can transparently transmit BPDU (Bridge Protocol Data Unit) packets.
- When using multiple switching hubs, make a star connection as shown in the connection examples 4.

[Connection example 1: Redundant configuration of RSTP-compliant switching hubs]

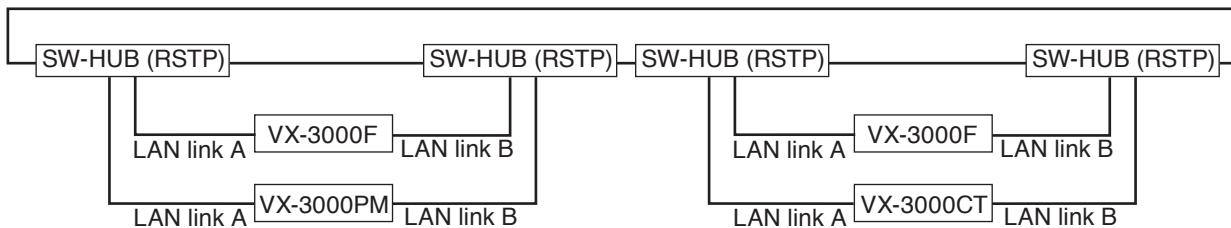

[Connection example 2: Redundant configuration of non-RSTP-compliant switching hubs]

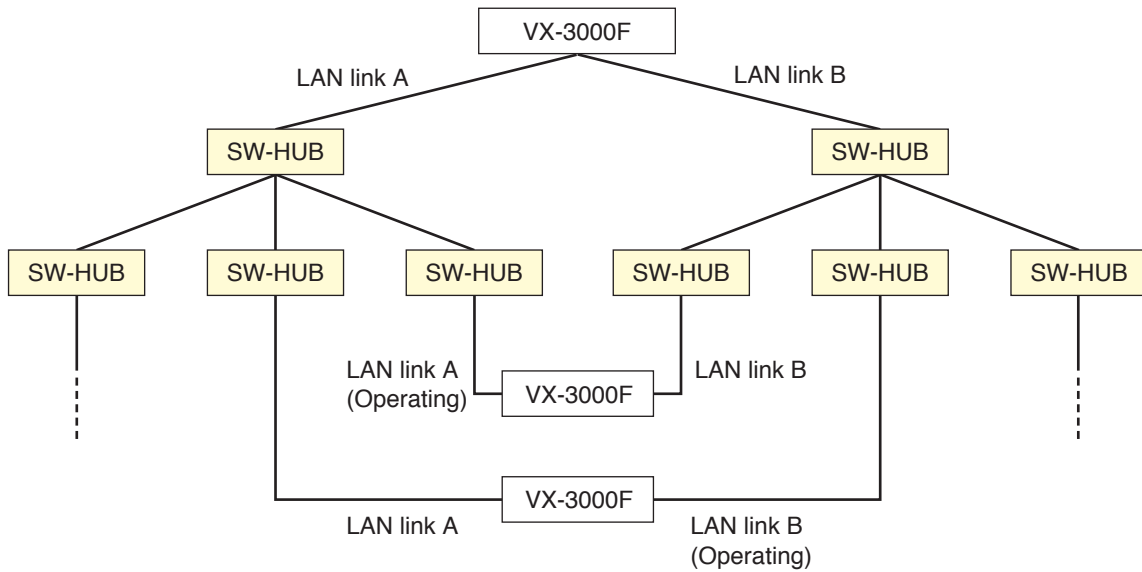

The above configuration prevents the system failure due to the cable disconnection or the power shutoff by connecting each of the VX-3000F's LAN link connectors A and B to a different switching hub.

[Connection example 3: Redundant configuration when no switching hubs are used]

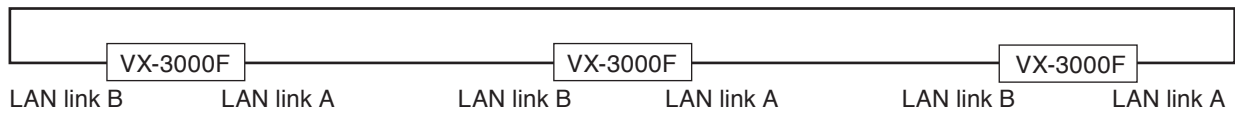

[Connection example 4: Non-redundant configuration of switching hubs]

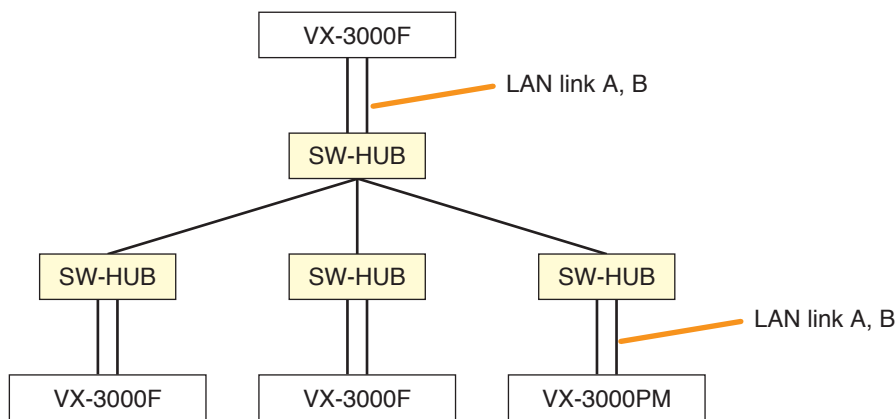

[Connection example 5: Non-redundant configuration when no switching hubs are used]

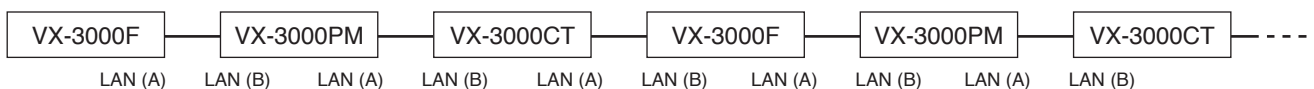

8.8.2. Redundant configuration of RSTP-compliant switching hubs

In the connection example below, both LAN link A and B terminals of each unit are connected to the same switching hub. By using switching hubs with failure status output function, if any one of switching hubs fails or the main line breaks, such a failure can be detected.

Notes

- Up to 7-level cascade is allowed for switching hub connections.
- After connection completion, reactivate the VX-3000 units.
- Perform spanning tree setting within switching hubs.
- The "External failure input" function needs be assigned to the unit's control input terminal to which the switching hub's failure status output is connected. (For details, see the separate Setting Software Instructions, "EVENT SETTINGS" and "Failure Pattern Settings.")

VX-3000F

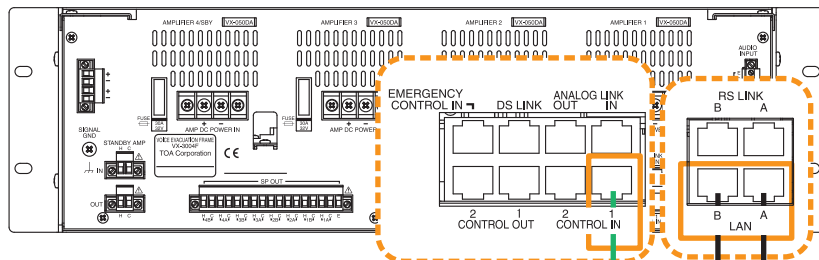

VX-3000F

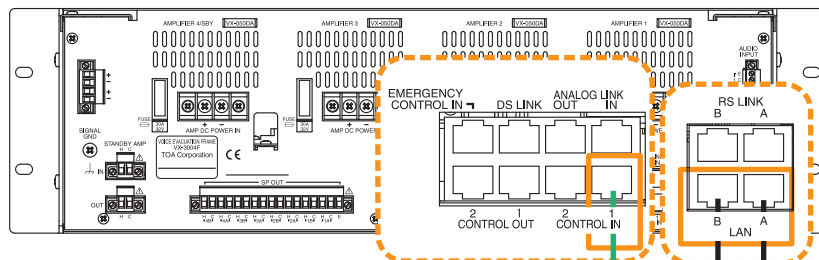

VX-3000PM

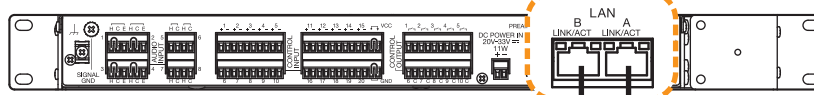

VX-3000CT

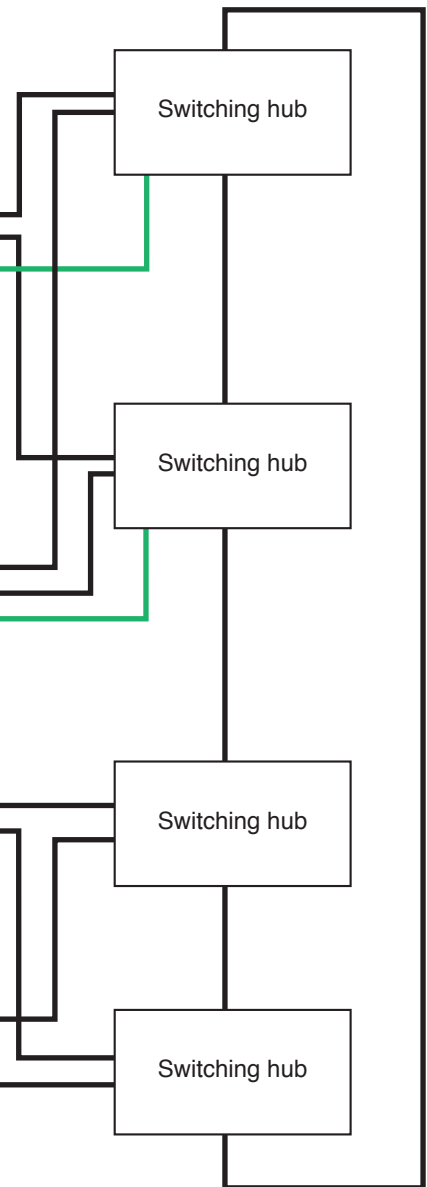

— : LAN
 — : Control line

Note: Contact your TOA dealer for more information on switching hubs.

8.8.3. Redundant configuration of switching hubs

In the connection example below, the LAN Link A and B connectors of each VX-3000F are individually connected to different switching hubs. By using switching hubs with failure status output function, if any one of switching hubs fails or the main line breaks, such a failure can be detected.

Notes

- Up to 7-level cascade is allowed for switching hub connections.
- After connection completion, reactivate the VX-3000F units.
- The "External failure input" function needs be assigned to the unit's control input terminal to which the switching hub's failure status output is connected. (For details, see the separate Setting Software Instructions, "EVENT SETTINGS" and "Failure Pattern Settings.")

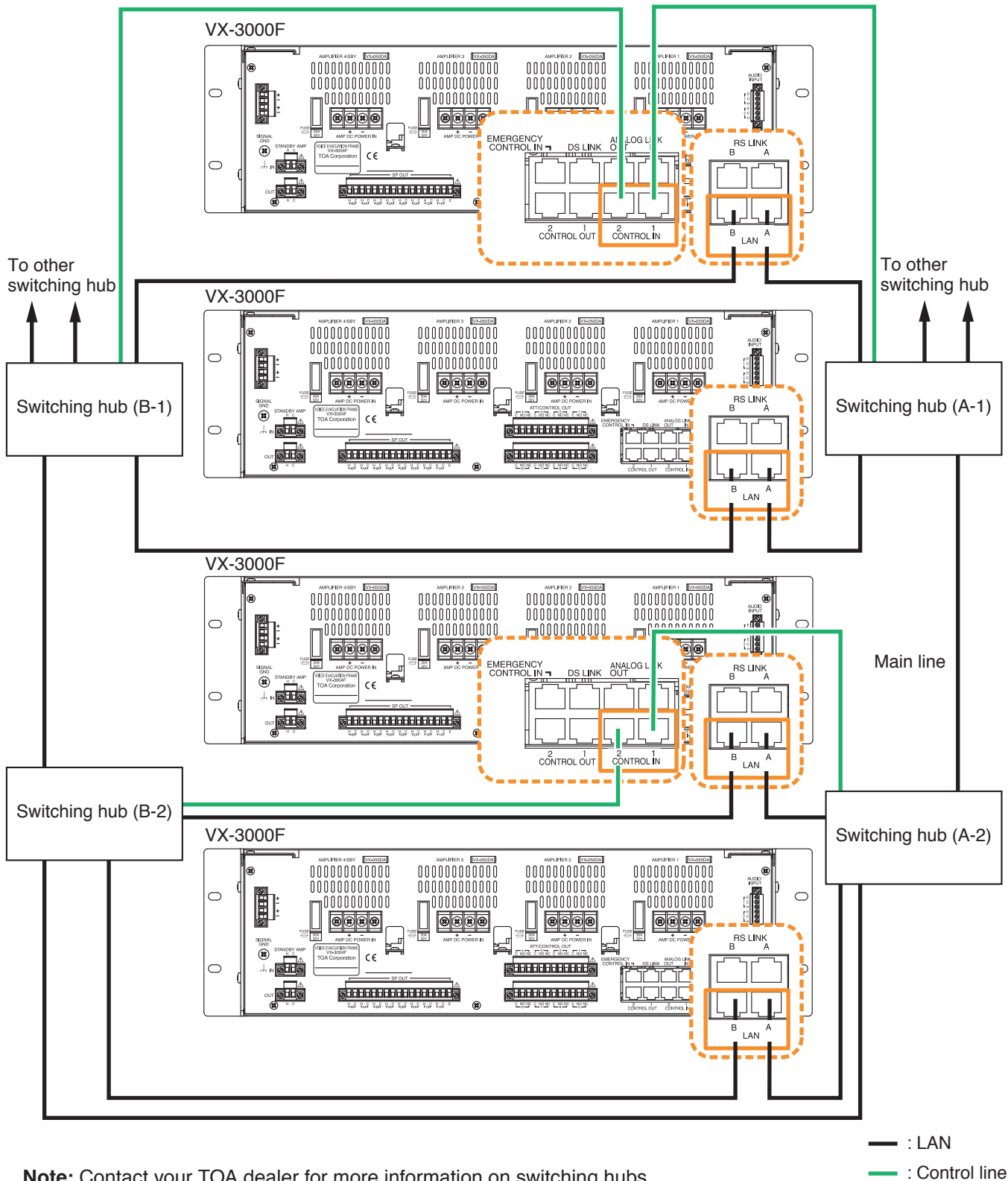

Note: Contact your TOA dealer for more information on switching hubs.

8.8.4. Redundant configuration when no switching hubs are used

In the connection example below, both the LAN link terminals A and B of each VX-3000F unit are connected to another VX-3000F.

Notes

- Up to 8 VX-3000Fs can be connected.
- After connection completion, reactivate the VX-3000F units.

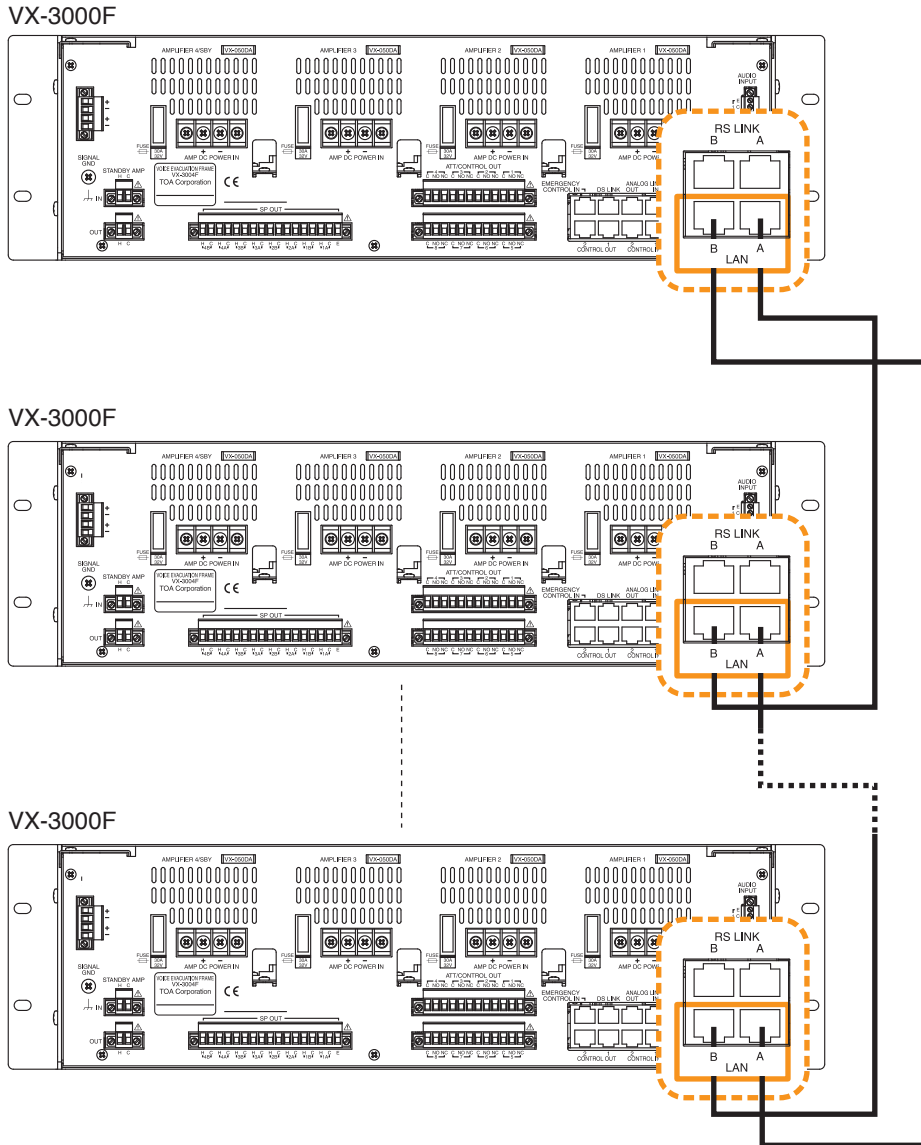

8.8.5. Non-redundant configuration of switching hubs

In the connection example below, both the LAN link terminals A and B of each VX-3000F or VX-3000PM unit are connected to the same switching hub.

Notes

- Up to 7-level cascade is allowed for switching hub connections.
- After connection completion, reactivate the VX-3000 units.

VX-3000F

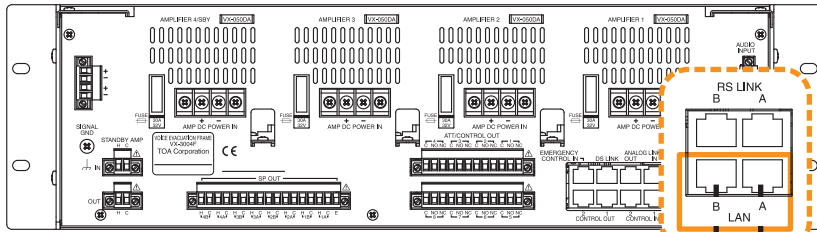

VX-3000F

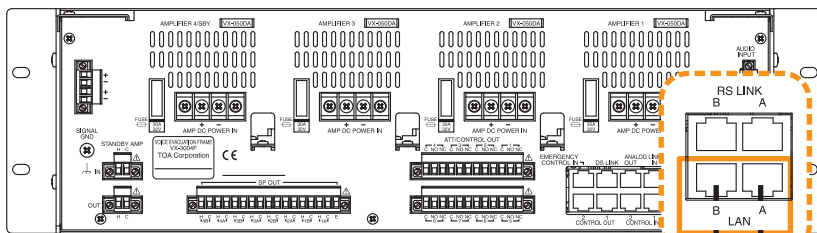

VX-3000F

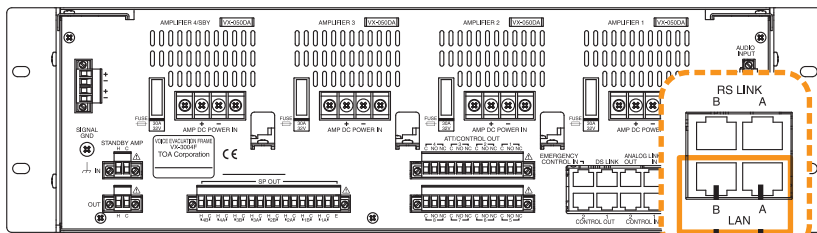

VX-3000F

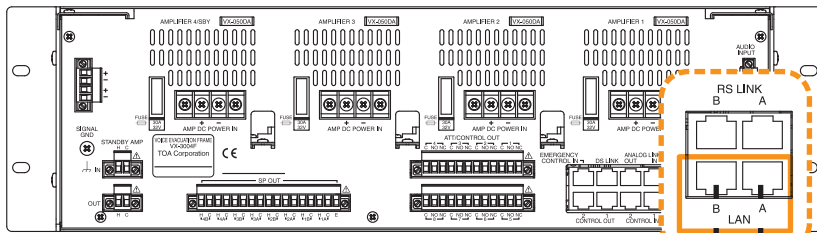

VX-3000PM

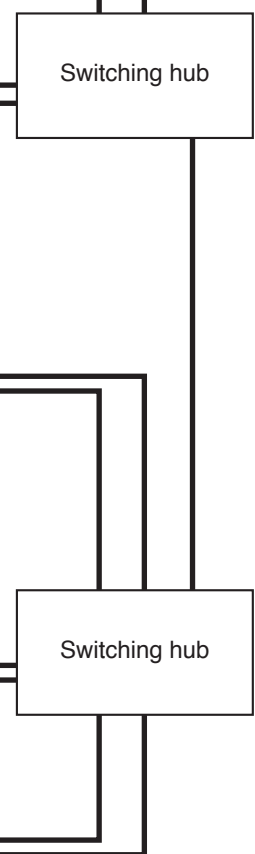
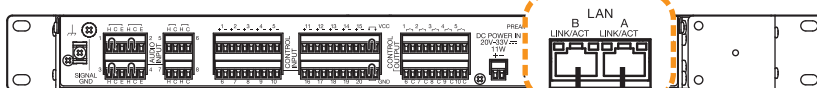

Note: Contact your TOA dealer for more information on switching hubs.

8.9. Sharing Standby Amplifier

Up to 8 VX-3000F units can share a single standby amplifier installed in any one of them. The standby amplifier must have the rated power output equal to or larger than the maximum output of the power amplifiers which share the standby amplifier.

Connect the standby amplifier output connector of the VX-3000F with the built-in standby amplifier to the next VX-3000F's standby amplifier input connector.

Similarly, make standby amplifier output/input connections for other units one after another.

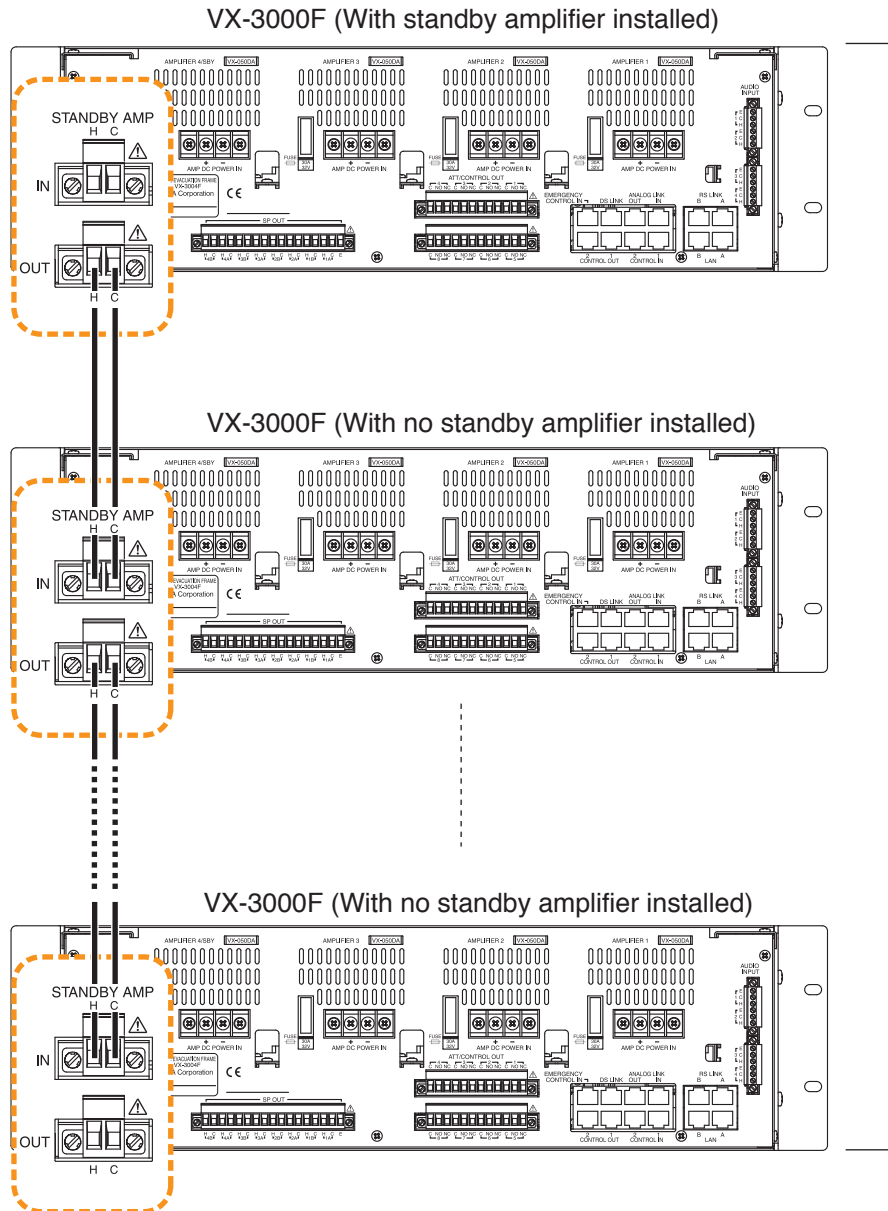

8.10. Speaker Selector Extension

The VX-3008F or VX-3016F can be used as speaker selector that extends the number of speaker lines without having a built-in power amplifier.

Up to 3 VX-3000F units for broadcast zone extension use can be connected to a single VX-3008F or VX-3016F. Connect the extension output connector of the VX-3008F or the VX-3016F with the built-in amplifier module to the next VX-3008F's or VX-3016F's extension input connector.

Similarly, make extension input/output connector connections for other units one after another.

Use EXTENSION 1 and 2 for VX-3008F connections, and EXTENSION 1 for VX-3016F connections.

Notes

- Only the VX-3008F can be used for the zone extension of the VX-3008F, and only the VX-3016F unit for the zone extension of the VX-3016F.
But Zone extension is not available when the VX-3016F is used in "2 channels, 8 speaker selectors" mode.
- Be sure to ground the Signal ground terminal.
Otherwise, a ground fault cannot be detected.

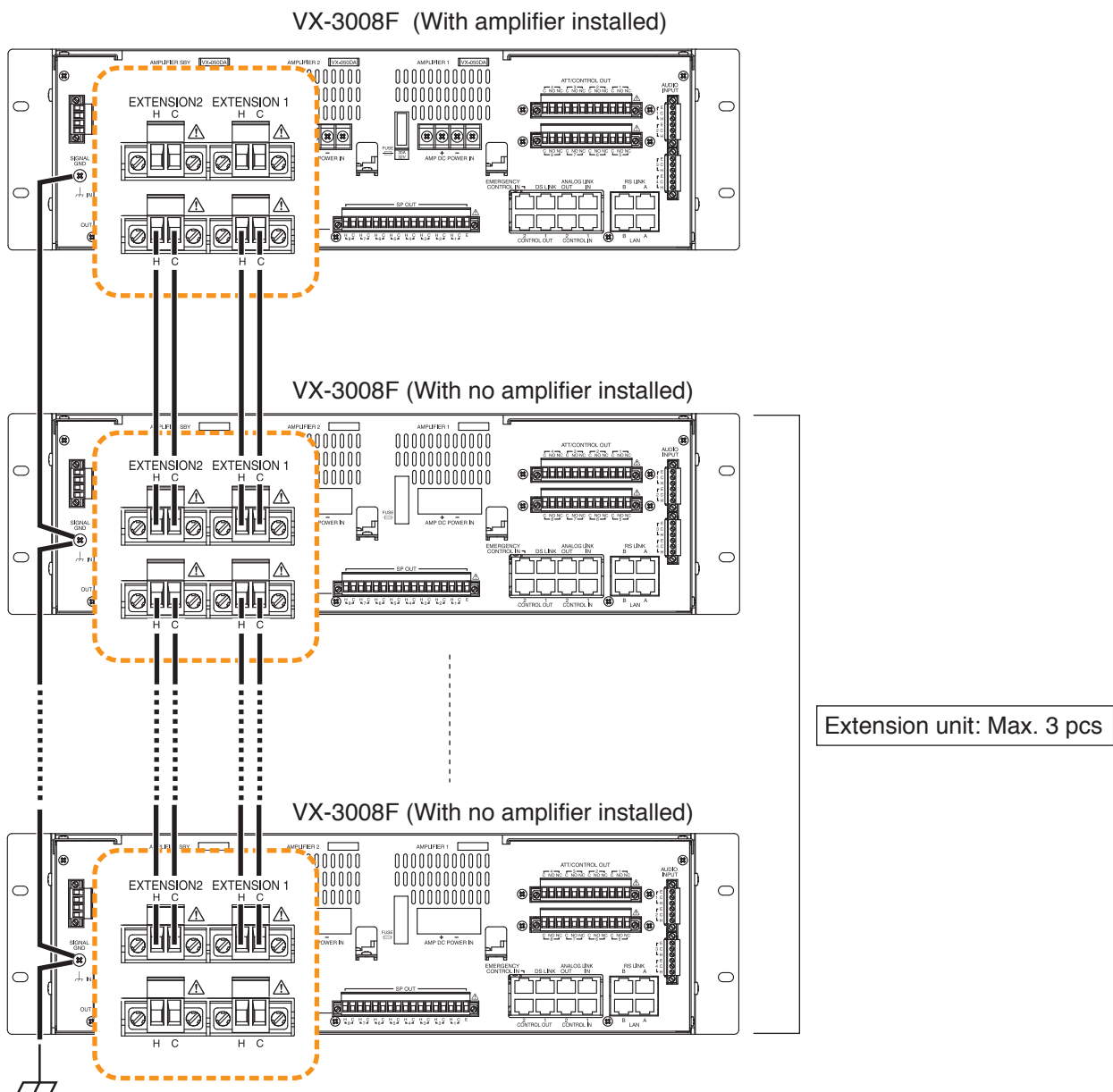

8.11. Analog Link Terminal Connections

Connecting all VX-3000F units within the system via Analog link connectors permits all-zone emergency broadcast to be initiated from the RM-300X Remote Microphone or the RM-200SF Fireman's Microphone through the connected lines if normal broadcasts cannot be made due to equipment failures. (See p. 3-30.) Make connections one of the VX-3000F's Analog link output connector to the Analog link input connector of the other VX-3000F.

Be sure to make the analog link connection when using 2 VX-3000F units or more.

Note

Total cable length connecting analog link terminals within the system must be kept shorter than 800 m.

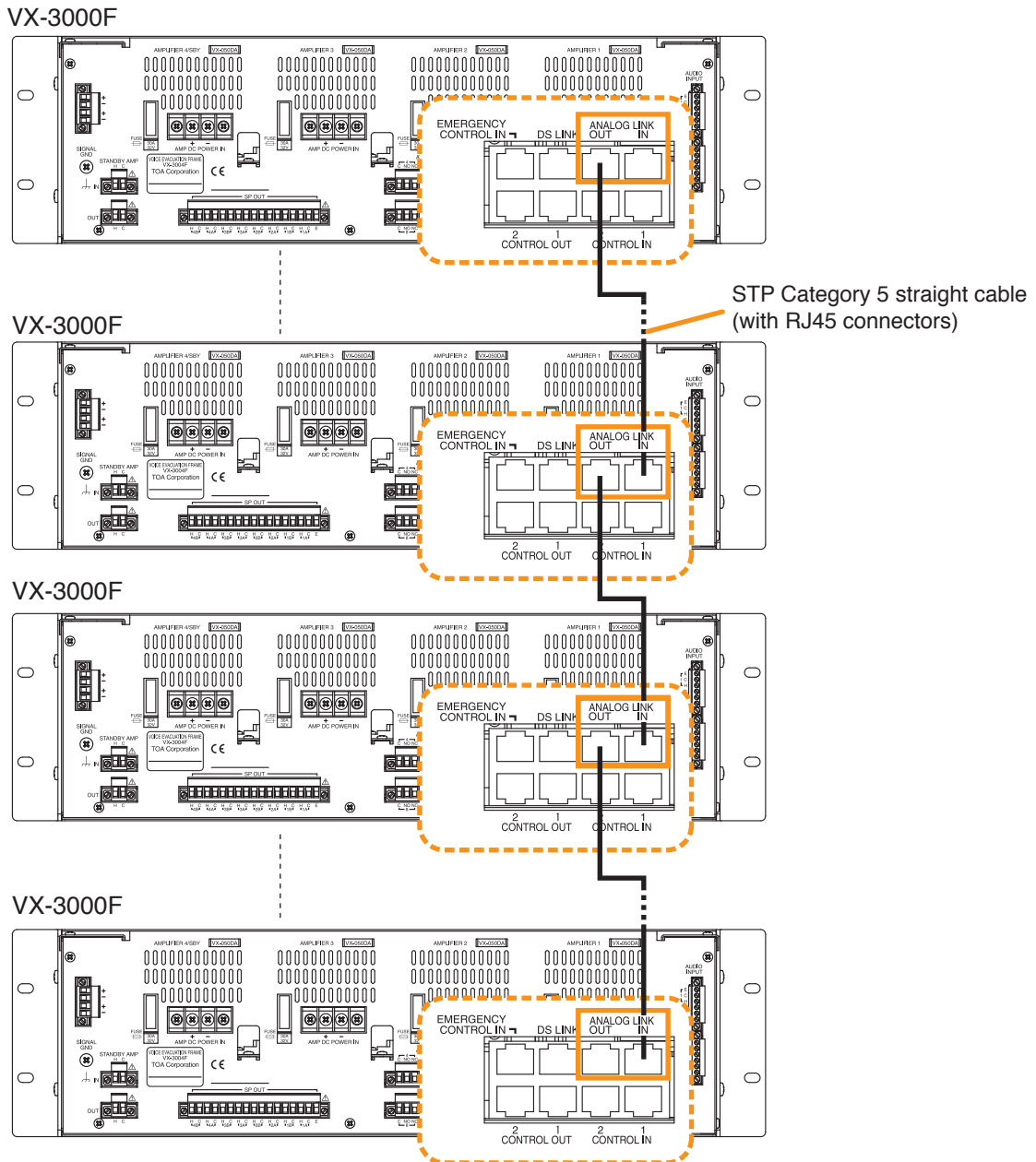

8.12. Preamp Matrix Panel Connection

8.12.1. Input equipment connections

Connect microphones or other music players to the audio inputs using 2-core shielded cables or single core shielded cables.

Eight Input channels (1 through 8) are provided for the audio inputs. Use 2-core shielded cables for connection to Audio inputs 1 through 4, and single core shielded cables to Audio inputs 5 through 8.

If the music player has a control output, connect the control output to the control input of the Preamplifier matrix panel.

The input signal levels of Audio inputs 1 through 4 of the Preamplifier matrix panel can be selected by the front-mounted input level setting switches.

Also, the front-mounted volume controls allow the individual volume adjustment of Audio inputs 1 through 8. Make the input-related settings such as purpose of use and audio source type using the VX-3000 Setting Software. (See the separate Setting Software Instructions, "Unit Configuration Settings.")

Note

Remove the jumper wire from the terminal to use.
Never remove others.

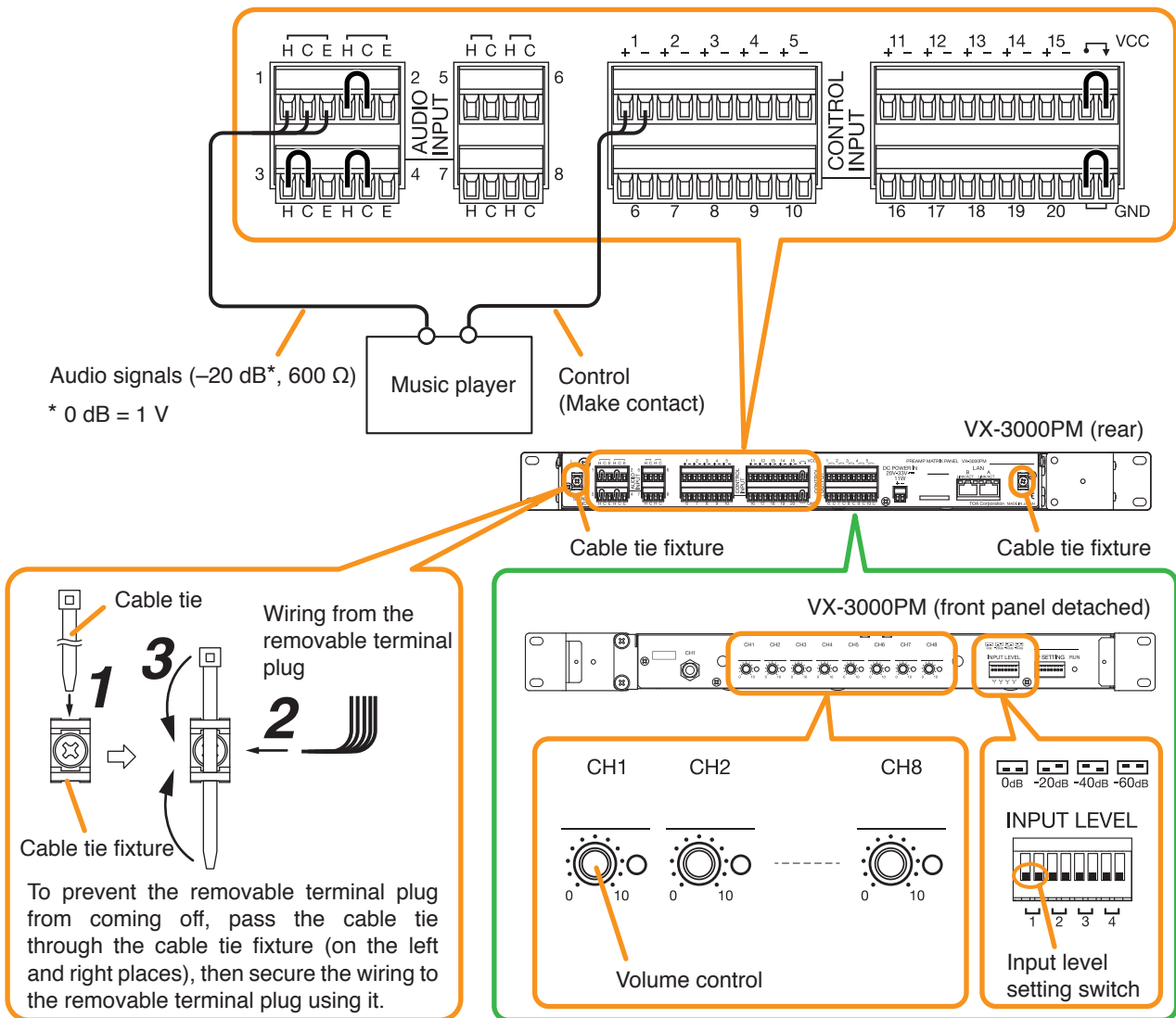

8.12.2. Control output terminal connections

These terminals provide control outputs.
Control signals (make contact) are output in synchronization with unit operation.

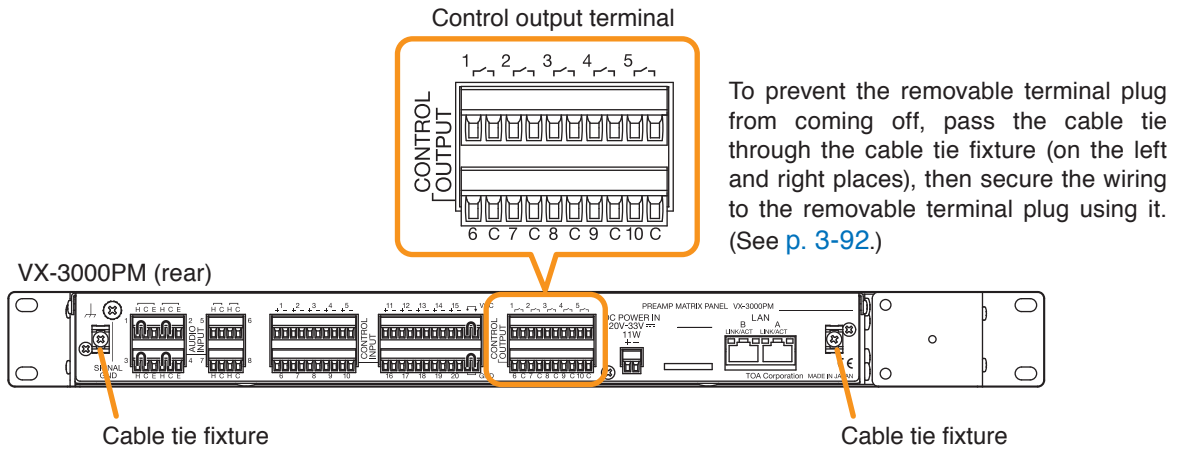

Use the VX-3000 Setting Software to set applications. (See the separate Setting Software Instructions, "Unit configuration setting," "Control Output Pattern Settings.")

8.12.3. Control input terminal connections

These terminals are non-voltage contact inputs.
Set the function and polarity using the VX-3000 Setting Software.
(See the separate Setting Software Instructions, "Control Inputs Event Settings.")

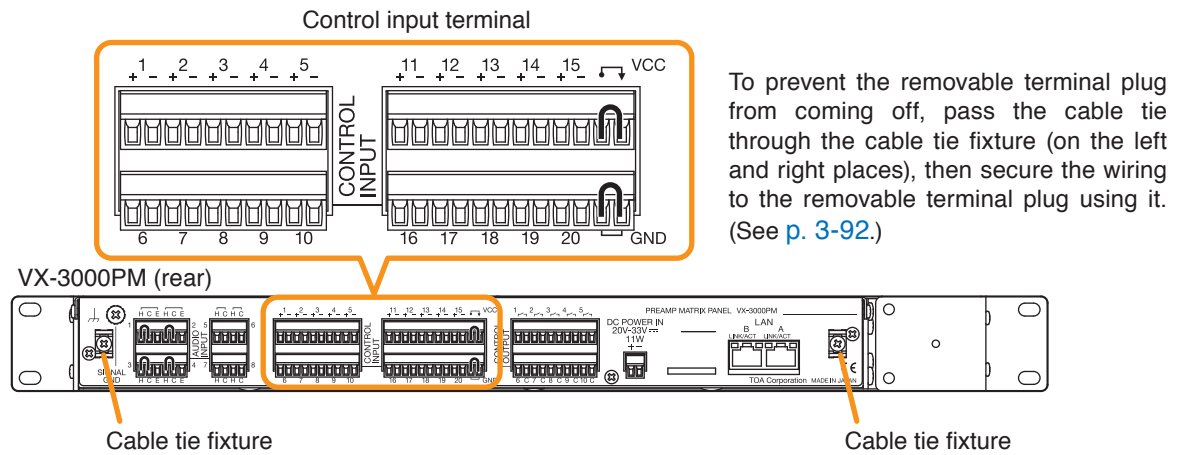

8.12.4. Power source connection

[When power is supplied from the VX-3000DS or VX-3150DS]

See the operating instructions supplied with the VX-3000DS or VX-3150DS.

[When power is supplied from the AC adapter]



VX-3000PM (rear)

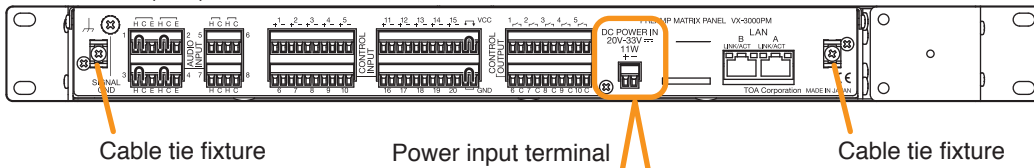

Cut off the DC plug of the AD-246 AC Adapter, and treat the tip of cable as follows.

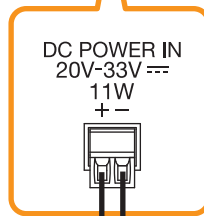
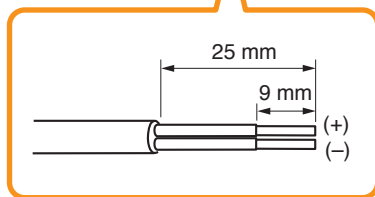
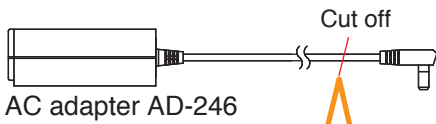

(-) AC adapter AD-246 or equivalent unit
(Use when no back up power supply is required.)
(+)

Note

To power the VX-3000PM even during power failures, a battery backup is also needed for the AC adapter. Or supply power to the VX-3000PM from the VX-3000DS or the VX-3150DS without using the AC adapter.

8.12.5. LAN link connectors connections

See "VX-3000 Unit's LAN Link Connector Connection" on p. 3-83

8.13. Control Panel Connections

8.13.1. Power supply connections

Note

Run the power cord through 2 cord clamps, then secure it taking care the cable does not go beyond the height range of the VX-3000CT's rear panel. Otherwise, the power cord may be pinched between other devices installed in the rack.

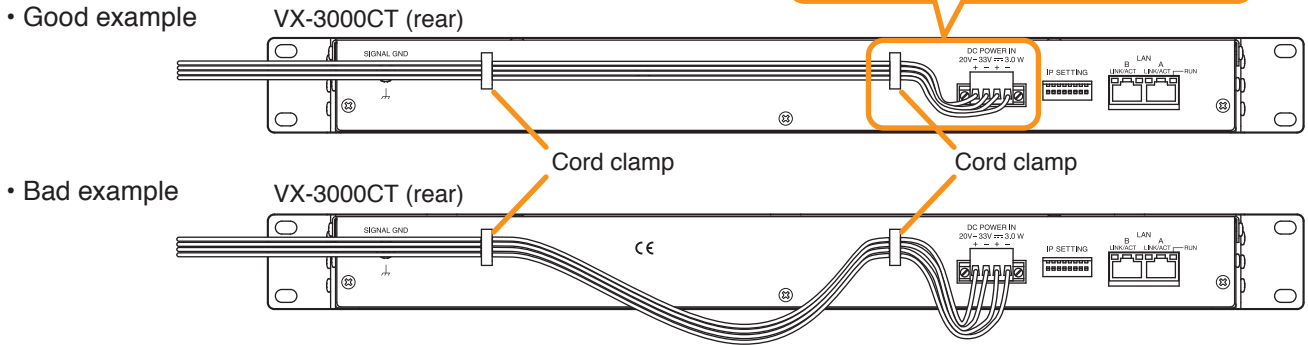

[When power is supplied from the VX-3000DS or VX-3150DS]

See the operating instructions supplied with the VX-3000DS or VX-3150DS.

[When power is supplied from the AC adapter]

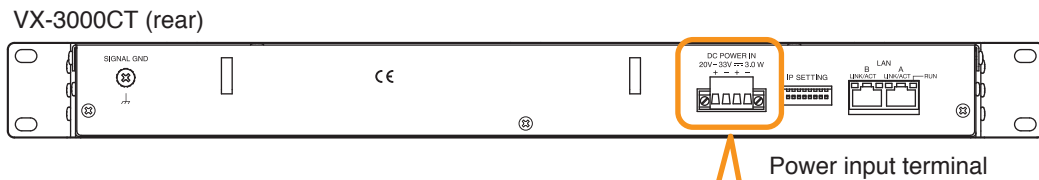
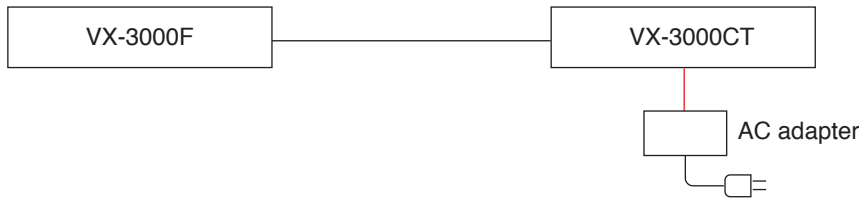

Cut off the DC plug of the AD-246 AC Adapter, and treat the tip of cable as follows.

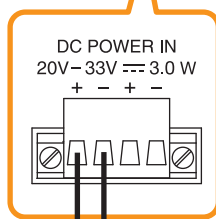
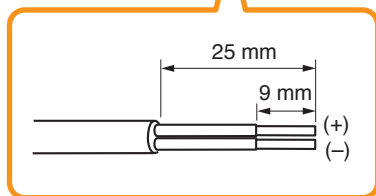
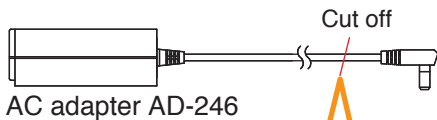

(-) AC adapter AD-246 or equivalent unit
(Use when no back up power supply is required.)
(+)

Note

To power the VX-3000CT even during power failures, a battery backup is also needed for the AC adapter. Or supply power to the VX-3000CT from the VX-3000DS or the VX-3150DS without using the AC adapter.

8.13.2. LAN link connectors connections

See "VX-3000 Unit's LAN Link Connector Connection" on p. 3-83

9. SPEAKER LINE INITIAL SETTING

To perform Speaker Line Surveillance, be sure to make the initial settings for the VX-3000F as follows after connection completion of the VX-3000 system.

9.1. Setting Items

[Initial impedance value setting]

The VX-3000F determines whether the speaker line is open or shorted using this initial value as reference value (normal impedance value).

Important

When using the surveillance function, be sure to set the initial impedance value.

[Speaker line OPEN sensitivity adjustment]

The sensitivity can be adjusted so that the VX-3000F can judge the speaker line open on the basis of the initial value.

[Speaker line SHORT sensitivity adjustment]

The sensitivity can be adjusted so that the VX-3000F can judge the speaker line shorted on the basis of the initial value.

9.2. OPEN/SHORT Criterion by Comparing the Current Value with the Initial Value

The set sensitivity values and the current value are expressed as ratios to the initial value (defined as 100 %). If OPEN and SHORT sensitivities remain factory-preset, the speaker line is judged shorted when the current value is less than half the initial value, and open when it is more than twice the initial value.

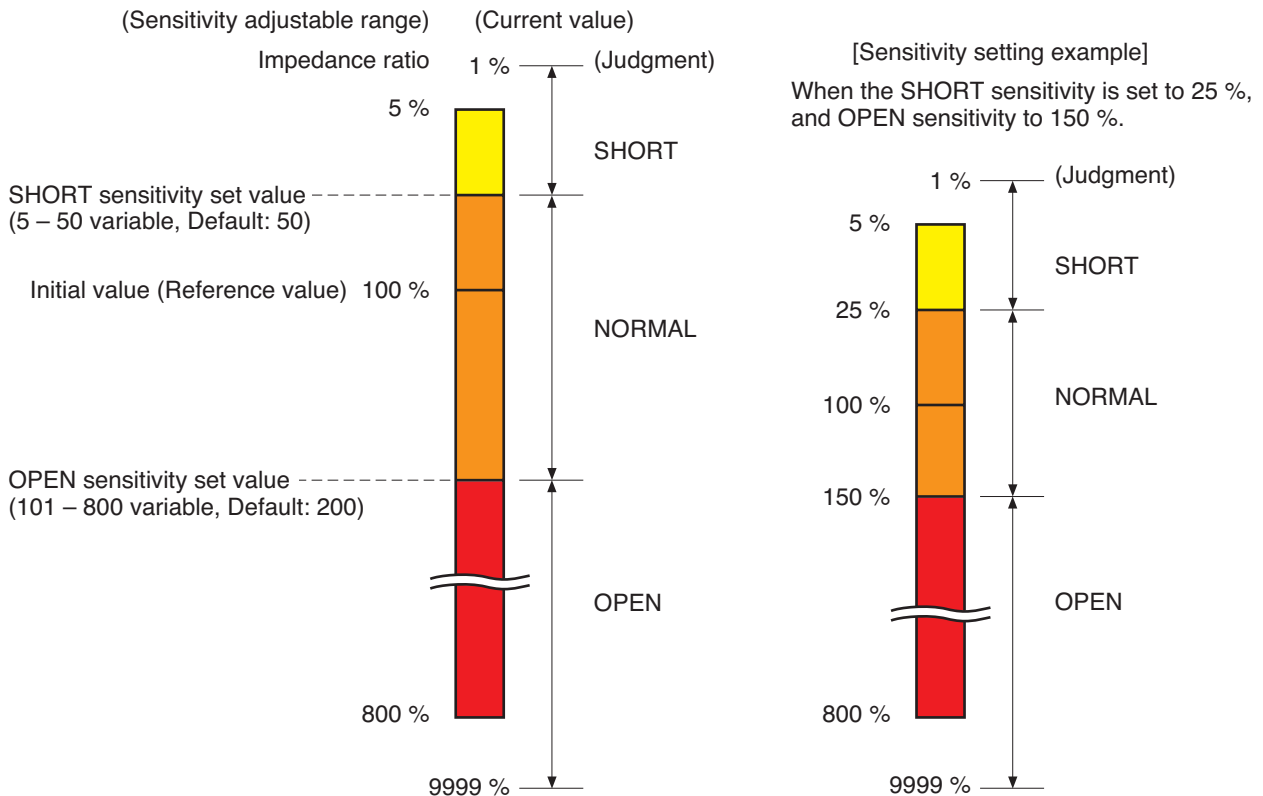

9.3. Setting Procedures

9.3.1. Setting an initial impedance value

Notes

- Set the failure detection function to ON using the VX-3000 Setting Software before setting the initial impedance value. Be sure to set the failure detection function to ON in advance. Otherwise, you cannot set the initial impedance value. (See the separate Setting Software Instructions, "Surveillance Function.")
- Be sure to perform this setting after completion of connection work.
- Be sure to reset the initial impedance value if any wiring or connection has been changed after completion of the setting.
- When measuring the speaker line impedance, be sure to stop all broadcasts in advance. Measuring cannot be made correctly when audio signals are being output.

- Step 1.** Detach the front panel.
Remove 4 fixing screws for front panel and detach the front panel.

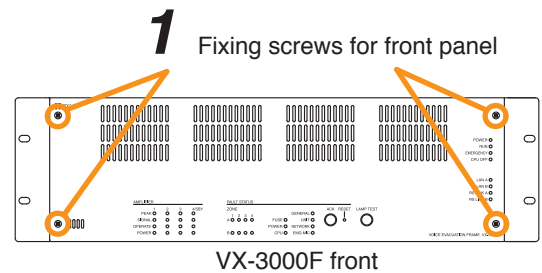

WARNING

There is a high voltage section inside the power amplifier's filter. Never insert your finger or metallic objects inside the unit.

- Step 2.** Press the Impedance initialize key.
Impedance measurement starts. Blinking cycle of the RUN indicator (the second LED from the top of the 8 LEDs arranged vertically on the right side) changes from 1-second intervals to 5-second intervals.

- Step 3.** Wait until the RUN indicator returns to normal state (flashing in 1-second intervals).

- Step 4.** Replace the front panel.
Secure it using 4 fixing screws for front panel .

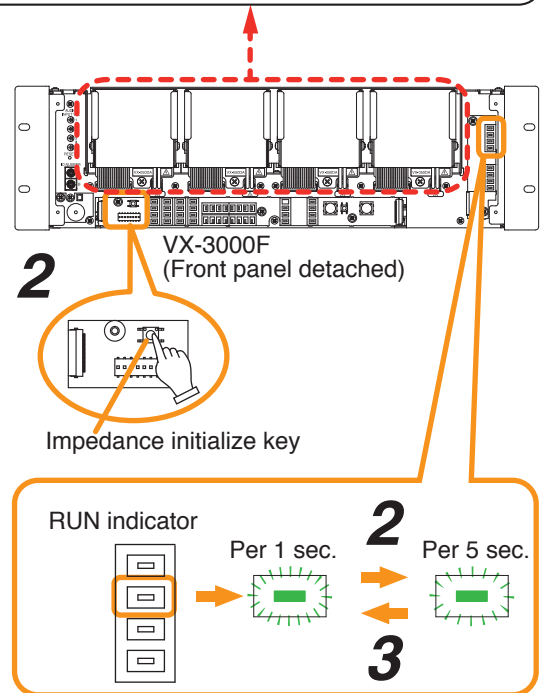

9.3.2. Adjusting the speaker line's OPEN sensitivity

Open sensitivity is expressed as the ratio to the initial value (defined as 100 %) and can be adjusted in the range of 101 % to 800 %. It is set to "200" for all the channels by default. Perform this setting using the VX-3000 Setting Software.

Note

Moving the setting closer to 101 % increases the OPEN sensitivity, and thus improves the accuracy of "OPEN" detection. Moving the setting closer to 800 % decreases the OPEN sensitivity, and thereby stabilizes the operation of the "OPEN" detection.

9.3.3. Adjusting the speaker line's SHORT sensitivity

SHORT sensitivity is expressed as the ratio to the initial value (defined as 100 %) and can be adjusted in the range of 5 % to 50 %. It is set to "50" for all the channels by default. Perform this setting using the VX-3000 Setting Software.

Note

Moving the setting closer to 5% decreases the SHORT sensitivity, and thereby stabilizes the operation of the "SHORT" detection.

Important

Adjust the SHORT sensitivity within the range not exceeding two times the power amplifier's rated load, as doing otherwise may cause damage to the power amplifier.

(Example)

- When the speakers with the rated load are connected: Set to "50."
- When the speakers with 1/2 rated load are connected: Set in the range of "25" to "50."

Chapter 4

APPENDIX

1. THE FIRMWARE VERSION CONFIRMATION

You can confirm the firmware version with the front-mounted indicators by setting the DIP switch inside the VX-3000F's front panel.

[Front-mounted indicators]

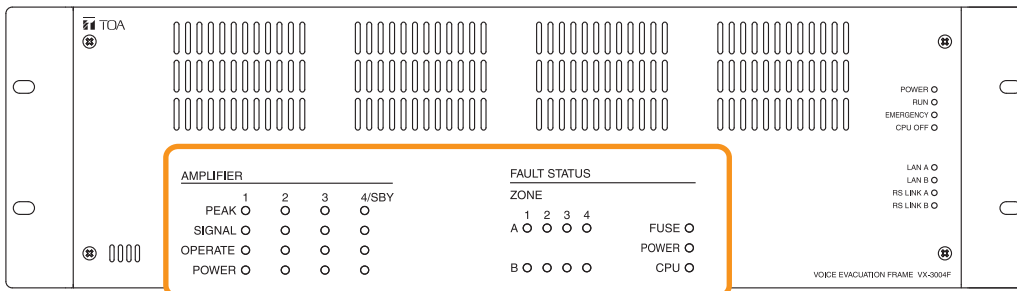

This figure shows VX-3004F.

Step 1. Detach the front panel.

Remove 4 fixing screws for front panel and detach the front panel.

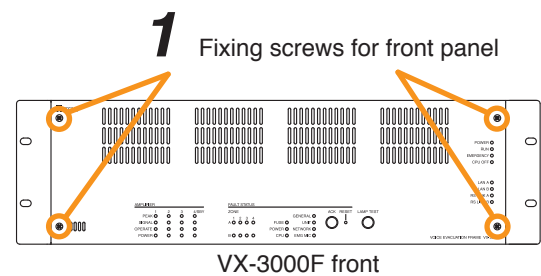

WARNING

There is a high voltage section inside the power amplifier's filter. Never insert your finger or metallic objects inside the unit.

Step 2. Set the switch 7 of the DIP switch to ON.

Step 3. Replace the front panel.

Secure it using 4 fixing screws for front panel.

Step 4. Confirm the firmware version by checking the indicators on the front panel.(See p. 4-3.)

Step 5. Detach the front panel again, and return the switch 7 of the DIP switch to OFF, restoring the unit to the original state.

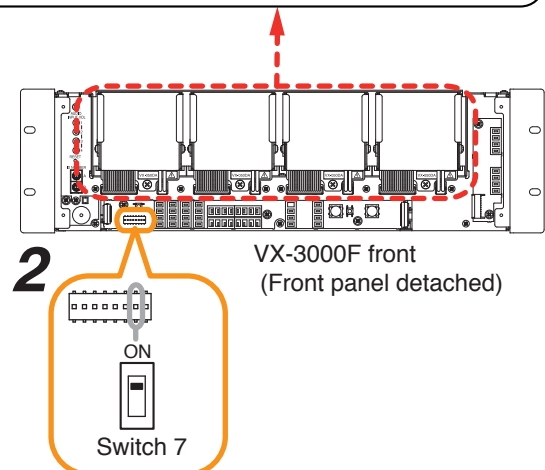

[How to confirm the firmware version]

- Firmware version indication

The VX-3000's firmware version is expressed as shown in the following example. Here, the individual numbers are denoted by (A) to (E).

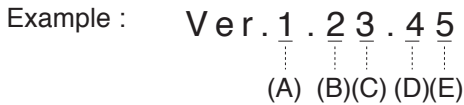

- Each digit is defined by the indicator status of from (A) to (E) as shown below.

[VX-3004F]

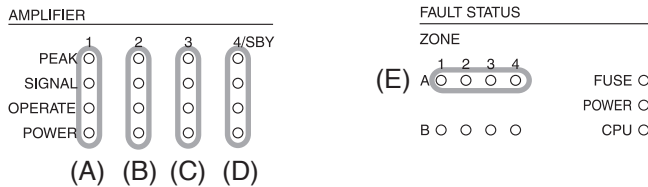

[VX-3008F]

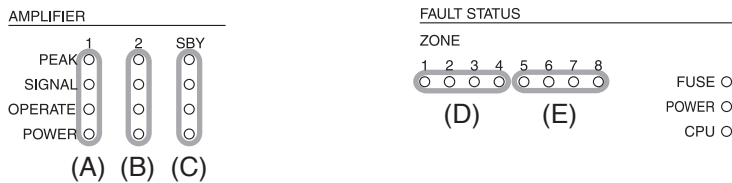

[VX-3016F]

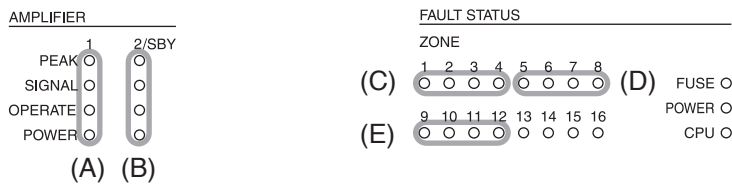

- The firmware version number is expressed in binary scale (0 = Unlit, 1 = Lit) by the 4 indicators of from (A) to (E). Convert the binary number shown by the indicators to the decimal number referring to the table below.

(In the case of the vertically arranged indicators)

- — The 4th digit in binary scale ... ④
- — The 3rd digit in binary scale ... ③
- — The 2nd digit in binary scale ... ②
- — The 1st digit in binary scale ... ①

(In the case of the horizontally arranged indicators)

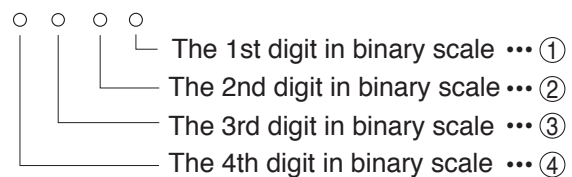

Decimal number		0	1	2	3	4	5	6	7	8	9
Indicator status	④	○	○	○	○	○	○	○	○	●	●
	③	○	○	○	○	●	●	●	●	○	○
	②	○	○	●	●	○	○	●	●	○	○
	①	○	●	○	●	○	●	○	●	○	●

○ : Unlit ● : Lit

(Display example of Ver. 1.23.45)

[VX-3004F]

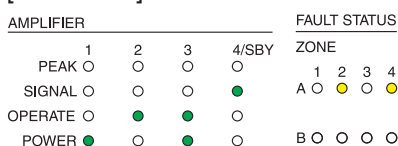

[VX-3008F]

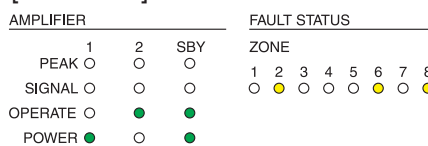

[VX-3016F]

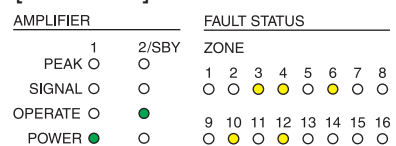

2. SPECIFICATIONS

2.1. VX-3004F Voice Evacuation Frame 4AB

Power Source	20 – 33 V DC, removable terminal block (4 pins)
Power Consumption	24 W (frame only) at 33 V DC input, 90 W (RS LINK: 2 A output) at 33 V DC input
LAN A, B	<p>Number of Connectors: 2 (LAN A, LAN B) Network I/F: 100BASE-TX Network Protocol: TCP, UDP, ARP, ICMP, RTP, IGMP, FTP, HTTP, NTP Spanning tree Protocol: RSTP Audio Transmission System: TOA Packet Audio*1 Audio Encoding Method: PCM Audio Sampling Frequency: 48 kHz Audio Quantifying Bit Number: 16 bits Connection Device: VX-3004F, VX-3008F, VX-3016F, NX-300, VX-3000PM, VX-3000CT, Switching HUB Connector: RJ45 connector Connection Cable: Category 5 twisted pair cable (CAT5) or greater Number of Stages of Cascade connection: Up to 7 Maximum Cable Distance: 100 m (328.08 ft)</p>
RS Link A, B	<p>Number of Connectors: 2 (RS LINK A, RS LINK B) Audio input level: 0 dB *2 Power feed: Max. 1 A per connector Connector: RJ45 connector Connection Cable: Shielded Category 5 twisted pair cable (CAT5-STP) or greater Maximum Cable Distance: 1200 m (3937.01 ft)</p>
DS Link	<p>Connection Device: DS LINK of Power supply units Connector: RJ45 connector Connection Cable: Shielded Category 5 twisted pair cable (CAT5-STP) or greater Maximum Cable Distance: 5 m (16.4 ft)</p>
Analog Link	<p>Number of Connectors: 1 input, 1 output Connection Device: VX-3004F, VX-3008F, VX-3016F Connector: RJ45 connector Connection Cable: Shielded Category 5 twisted pair cable (CAT5-STP) or greater Maximum Cable Distance: 800 m (2624.67 ft)</p>
Control Input 1, 2	<p>16 inputs, no-voltage make contact input, open voltage: 24 V DC, short-circuit current: 2 mA Fault Detection System: Short circuit, Open circuit, Method: Voltage detect Connector: RJ45 connector Connection Cable: Shielded Category 5 twisted pair cable (CAT5-STP) or greater</p>
Emergency Control IN	<p>Input 2: Isolated voltage input, –24 to +24 V Connector: RJ45 connector Connection Cable: Category 5 twisted pair cable (CAT5) or greater</p>
VOX Function	<p>Threshold: –60 to 0 dB (1 dB steps) Hysteresis: 0 to +10 dB Hold time: 10 ms – 10 s Settable for each audio input</p>

Control Output 1, 2	<p>General outputs : 8 with CONTROL OUTPUT 1 Exclusive outputs : 3 with CONTROL OUTPUT 2 GENERAL FAULT, CPU FAULT, CPU OFF</p> <p>No-voltage make contact, electrical contact output, control current: 10 mA, withstand voltage: 28 V DC</p> <p>Connector: RJ45 connector Connection Cable: Shielded Category 5 twisted pair cable (CAT5-STP) or greater</p>
ATT/Control Output	<p>8 outputs, no-voltage make contact, relay contact (NC, NO, C), control current: 2 mA to 5 A, withstand voltage: 125 V AC, 40 V DC</p> <p>Connector: Removable terminal block (12 pins) ... 2</p>
Audio Input 1, 2, 3, 4	<p>4 inputs</p> <p>Sensitivity: LINE: -20 dB^{*2}, MIC: -60 dB^{*2} LINE/MIC/ANC Sensor (changeable with setting software)</p> <p>Gain Control: Volume adjustable with volume control (internal front panel) $-\infty$ to 0 dB</p> <p>Input Impedance: 47 kΩ, electronically-balanced</p> <p>Frequency Response: 40 Hz to 20 kHz $\pm 1 \text{ dB}$ (at DA CONTROL LINK, 0 dB output)</p> <p>Distortion: 1% or less (at DA CONTROL LINK, 0 dB output, 1 kHz)</p> <p>Signal to Noise Ratio: 60 dB or more (at DA CONTROL LINK, A-weighted)</p> <p>Phantom Power Supply: 24 V DC, can be set with setting software</p> <p>Connector: Removable terminal block (6 pins) ... 2</p>
Digital Signal Processing	
Feedback Suppression Function (FBS)	<p>7 filters (auto), Settable for each audio input and RS LINK (A/B)</p>
Equalizer/Filter	<p>3 bands for each audio input and RS LINK (A/B), 6 bands for each amplifier output</p> <p>Parametric equalizer: 20 Hz – 20 kHz, $\pm 15 \text{ dB}$, Q: 0.267 – 69.249</p> <p>Filtering: High-pass filter 20 Hz – 20 kHz, 6 dB/oct, 12 dB/oct Low-pass filter 20 Hz – 20 kHz, 6 dB/oct, 12 dB/oct High shelving filter 6 – 20 kHz, $\pm 15 \text{ dB}$ Low shelving filter 20 – 500 Hz, $\pm 15 \text{ dB}$ Notch filter (amplifier output only) 20 Hz – 20 kHz, Q: 8.651 – 69.249 All-pass filter (amplifier output only) 20 Hz – 20 kHz, Q: 0.267 – 69.249 Horn equalizer (amplifier output only) 20 kHz, 0 to +18 dB (0.5 dB steps)</p>
Compressor	<p>Threshold: -20 to 0 dB (1 dB steps)</p> <p>Ratio: 1:1, 1.1:1, 1.2:1, 1.3:1, 1.5:1, 1.7:1, 2:1, 2.3:1, 2.6:1, 3:1, 4:1, 5:1, 7:1, 8:1, 10:1, 12:1, 20:1, ∞:1</p> <p>Attack time: 0.2 ms – 5 s Release time: 10 ms – 5 s</p> <p>Gain: $-\infty$ to +10 dB</p> <p>Knee type: hard knee, middle knee, soft knee</p>
Delay	For each amplifier output, 0 – 2730 ms (0.021 ms steps)
ANC (Ambient Noise Control)	<p>Amplifier output level control, Automatic sensor input reference level measuring, Sensor input reference level fine adjustment</p> <p>Maximum output signal level control: -15 to 0 dB Minimum output signal level control: -18 to -3 dB</p> <p>Sample time setting: 10 s, 20 s, 30 s, 1 min, 5 min Gain ratio setting: (Ambient noise: Output signal level) 6:3, 5:3, 4:3, 3:3, 3:4, 3:5, 3:6</p> <p>Ambient noise measuring frequency setting: 20 Hz – 20 kHz, 3 points</p>
Program Timer	<p>Weekly program method</p> <p>Daily program: 50 events, 10 types Holiday program: 50 types</p>
Time Adjustment	Control input, NTP

Speaker Line	4 channels (with A/B LINE speaker output), 1 Earth terminal Maximum Voltage/Current: 100 Vrms, 5 Arms Connector: Removable terminal block (17 pins) ... 1 Fault Detection System: Short circuit, Open circuit, Ground fault, Method: Impedance or End of line
Standby Amplifier Input/Output	Input: 1, Output: 1 Maximum Voltage/Current: 100 Vrms, 5 Arms Connector: Removable terminal block (2 pins) ... 2
Module* ³	Number of modules: 4 DA CONTROL LINK ... 4, DA OUTPUT LINK ... 4 (Used only when a power amplifier module is installed)
Indicators	POWER (green) ... 1, RUN (green) ... 1, EMERGENCY (red) ... 1, CPU OFF (red) ... 1, LAN A (green) ... 1, LAN B (green) ... 1, RS LINK A (green) ... 1, RS LINK B (green) ... 1 FAULT STATUS (yellow): GENERAL ... 1, UNIT ... 1, NETWORK ... 1, EMG MIC ... 1, FUSE ... 1, POWER ... 1, CPU ... 1, ZONE ... 8 AMPLIFIER: PEAK (red) ... 4, SIGNAL (green) ... 4, OPERATE (green) ... 4, POWER (green) ... 4
Operation	Fault Control Switch ... 2 (ACK/RESET) Test Switch ... 1 (LAMP TEST) Setting Switch: ID NUMBER, RESET, IMPEDANCE, Setting (internal front panel)
Operating Temperature	-5 to +45 °C (23 to 113 °F)
Operating Humidity	90% RH or less (no condensation)
Finish	Panel: Surface-treated steel plate, black, 30% glossy, paint
Dimensions	483 (w) x 132.6 (h) x 345 (d) mm (19.02" x 5.22" x 13.58")
Weight	7.6 kg (16.75 lb)

*1 TOA's unique technology which makes it possible to transmit high-quality audio signals in real time over an IP network

*2 0 dB = 1 V

*3 Module: Digital power amplifier module, Line output module

Note: The design and specifications are subject to change without notice for improvement.

• Accessories

Rack mounting screw 5 x 12	4
CD (PC setting software)	1
Removable terminal plug (2 pins)	2
Removable terminal plug (4 pins)	1
Removable terminal plug (6 pins)	2
Removable terminal plug (12 pins)	2
Removable terminal plug (17 pins)	1
Ferrite cable clamp	2

2.2. VX-3008F Voice Evacuation Frame 8SS

Power Source	20 – 33 V DC, removable terminal block (4 pins)
Power Consumption	24 W (frame only) at 33 V DC input, 90 W (RS LINK: 2 A output) at 33 V DC input
LAN A, B	<p>Number of Connectors: 2 (LAN A, LAN B) Network I/F: 100BASE-TX Network Protocol: TCP, UDP, ARP, ICMP, RTP, IGMP, FTP, HTTP, NTP Spanning tree Protocol: RSTP Audio Transmission System: TOA Packet Audio*1 Audio Encoding Method: PCM Audio Sampling Frequency: 48 kHz Audio Quantifying Bit Number: 16 bits Connection Device: VX-3004F, VX-3008F, VX-3016F, NX-300, VX-3000PM, VX-3000CT, Switching HUB Connector: RJ45 connector Connection Cable: Category 5 twisted pair cable (CAT5) or greater Number of Stages of Cascade connection: Up to 7 Maximum Cable Distance: 100 m (328.08 ft)</p>
RS Link A, B	<p>Number of Connectors: 2 (RS LINK A, RS LINK B) Audio input level: 0 dB*2 Power feed: Max. 1 A per connector Connector: RJ45 connector Connection Cable: Shielded Category 5 twisted pair cable (CAT5-STP) or greater Maximum Cable Distance: 1200 m (3937.01 ft)</p>
DS Link	<p>Connection Device: DS LINK of Power supply units Connector: RJ45 connector Connection Cable: Shielded Category 5 twisted pair cable (CAT5-STP) or greater Maximum Cable Distance: 5 m (16.4 ft)</p>
Analog Link	<p>Number of Connectors: 1 input, 1 output Connection Device: VX-3004F, VX-3008F, VX-3016F Connector: RJ45 connector Connection Cable: Shielded Category 5 twisted pair cable (CAT5-STP) or greater Maximum Cable Distance: 800 m (2624.67 ft)</p>
Control Input 1, 2	<p>16 inputs, no-voltage make contact input, open voltage: 24 V DC, short-circuit current: 2 mA Fault Detection System: Short circuit, Open circuit, Method: Voltage detect Connector: RJ45 connector Connection Cable: Shielded Category 5 twisted pair cable (CAT5-STP) or greater</p>
Emergency Control IN	<p>Input 2: Isolated voltage input, –24 to +24 V Connector: RJ45 connector Connection Cable: Category 5 twisted pair cable (CAT5) or greater</p>
VOX Function	<p>Threshold: –60 to 0 dB (1 dB steps) Hysteresis: 0 to +10 dB Hold time: 10 ms – 10 s Settable for each audio input</p>
Control Output 1, 2	<p>General outputs : 8 with CONTROL OUTPUT 1 Exclusive outputs : 3 with CONTROL OUTPUT 2 GENERAL FAULT, CPU FAULT, CPU OFF No-voltage make contact, electrical contact output, control current: 10 mA, withstand voltage: 28 V DC Connector: RJ45 connector Connection Cable: Shielded Category 5 twisted pair cable (CAT5-STP) or greater</p>

ATT/Control Output	8 outputs, no-voltage make contact, relay contact (NC, NO, C), control current: 2 mA to 5 A, withstand voltage: 125 V AC, 40 V DC Connector: Removable terminal block (12 pins) ...2
Audio Input 1, 2, 3, 4	4 inputs Sensitivity: LINE: -20 dB*2, MIC: -60 dB*2 LINE/MIC/ANC Sensor (changeable with setting software) Gain Control: Volume adjustable with volume control (internal front panel) -∞ to 0 dB Input Impedance: 47 kΩ, electronically-balanced Frequency Response: 40 Hz to 20 kHz ±1 dB (at DA CONTROL LINK, 0 dB output) Distortion: 1% or less (at DA CONTROL LINK, 0 dB output, 1 kHz) Signal to Noise Ratio: 60 dB or more (at DA CONTROL LINK, A-weighted) Phantom Power Supply: 24 V DC, can be set with setting software Connector: Removable terminal block (6 pins) ... 2
Digital Signal Processing	
Feedback Suppression Function (FBS)	7 filters (auto), Settable for each audio input and RS LINK (A/B)
Equalizer/Filter	3 bands for each audio input and RS LINK (A/B), 6 bands for each amplifier output Parametric equalizer: 20 Hz – 20 kHz, ±15 dB, Q: 0.267 – 69.249 Filtering: High-pass filter 20 Hz – 20 kHz, 6 dB/oct, 12 dB/oct Low-pass filter 20 Hz – 20 kHz, 6 dB/oct, 12 dB/oct High shelving filter 6 – 20 kHz, ±15 dB Low shelving filter 20 – 500 Hz, ±15 dB Notch filter (amplifier output only) 20 Hz – 20 kHz, Q: 8.651 – 69.249 All-pass filter (amplifier output only) 20 Hz – 20 kHz, Q: 0.267 – 69.249 Horn equalizer (amplifier output only) 20 kHz, 0 to +18 dB (0.5 dB steps)
Compressor	Threshold: -20 to 0 dB (1 dB steps) Ratio: 1:1, 1.1:1, 1.2:1, 1.3:1, 1.5:1, 1.7:1, 2:1, 2.3:1, 2.6:1, 3:1, 4:1, 5:1, 7:1, 8:1, 10:1, 12:1, 20:1, ∞:1 Attack time: 0.2 ms – 5 s Release time: 10 ms – 5 s Gain: -∞ to +10 dB Knee type: hard knee, middle knee, soft knee
Delay	For each amplifier output, 0 – 2730 ms (0.021 ms steps)
ANC (Ambient Noise Control)	Amplifier output level control, Automatic sensor input reference level measuring, Sensor input reference level fine adjustment Maximum output signal level control: -15 to 0 dB Minimum output signal level control: -18 to -3 dB Sample time setting: 10 s, 20 s, 30 s, 1 min, 5 min Gain ratio setting: (Ambient noise: Output signal level) 6:3, 5:3, 4:3, 3:3, 3:4, 3:5, 3:6 Ambient noise measuring frequency setting: 20 Hz – 20 kHz, 3 points
Program Timer	Weekly program method Daily program: 50 events, 10 types Holiday program: 50 types
Time Adjustment	Control input, NTP
Speaker Line	8 channels, 1 Earth terminal Maximum Voltage/Current: 100 Vrms, 5 Arms Connector: Removable terminal block (17 pins) ... 1 Fault Detection System: Short circuit, Open circuit, Ground fault, Method: Impedance or End of line
Standby Amplifier Input/Output	Input: 1, Output: 1 Maximum Voltage/Current: 100 Vrms, 5 Arms Connector: Removable terminal block (2 pins) ... 2

Extension Amplifier Input/Output	Input: 2, Output: 2 Maximum Voltage/Current: 100 Vrms, 5 Arms Connector: Removable terminal block (2 pins) ... 4
Module* ³	Number of modules: 3 (When the line output module is installed ... 2) DA CONTROL LINK ... 3, DA OUTPUT LINK ... 3 (Used only when a power amplifier module is installed)
Indicators	POWER (green) ... 1, RUN (green) ... 1, EMERGENCY (red) ... 1, CPU OFF (red) ... 1, LAN A (green) ... 1, LAN B (green) ... 1, RS LINK A (green) ... 1, RS LINK B (green) ... 1 FAULT STATUS (yellow): GENERAL ... 1, UNIT ... 1, NETWORK ... 1, EMG MIC ... 1, FUSE ... 1, POWER ... 1, CPU ... 1, ZONE ... 8 AMPLIFIER: PEAK (red) ... 3, SIGNAL (green) ... 3, OPERATE (green) ... 3, POWER (green) ... 3
Operation	Fault Control Switch ...2 (ACK/RESET) Test Switch ...1 (LAMP TEST) Setting Switch: ID NUMBER, RESET, IMPEDANCE, Setting (internal front panel)
Operating Temperature	-5 to +45 °C (23 to 113 °F)
Operating Humidity	90% RH or less (no condensation)
Finish	Panel: Surface-treated steel plate, black, 30% glossy, paint
Dimensions	483 (w) x 132.6 (h) x 345 (d) mm (19.02" x 5.22" x 13.58")
Weight	7.9 kg (17.42 lb)

*¹ TOA's unique technology which makes it possible to transmit high-quality audio signals in real time over an IP network

*² 0 dB = 1 V

*³ Module: Digital power amplifier module, Line output module

Note: The design and specifications are subject to change without notice for improvement.

• Accessories

Rack mounting screw 5 x 12	4
CD (PC setting software)	1
Removable terminal plug (2 pins)	6
Removable terminal plug (4 pins)	1
Removable terminal plug (6 pins)	2
Removable terminal plug (12 pins)	2
Removable terminal plug (17 pins)	1
Ferrite cable clamp	2

2.3. VX-3016F Voice Evacuation Frame 16SS

Power Source	20 – 33 V DC, removable terminal block (4 pins)
Power Consumption	29 W (frame only) at 33 V DC input, 95 W (RS LINK: 2 A output) at 33 V DC input
LAN A, B	<p>Number of Connectors: 2 (LAN A, LAN B) Network I/F: 100BASE-TX Network Protocol: TCP, UDP, ARP, ICMP, RTP, IGMP, FTP, HTTP, NTP Spanning tree Protocol: RSTP Audio Transmission System: TOA Packet Audio*1 Audio Encoding Method: PCM Audio Sampling Frequency: 48 kHz Audio Quantifying Bit Number: 16 bits Connection Device: VX-3004F, VX-3008F, VX-3016F, NX-300, VX-3000PM, VX-3000CT, Switching HUB Connector: RJ45 connector Connection Cable: Category 5 twisted pair cable (CAT5) or greater Number of Stages of Cascade connection: Up to 7 Maximum Cable Distance: 100 m (328.08 ft)</p>
RS Link A, B	<p>Number of Connectors: 2 (RS LINK A, RS LINK B) Audio input level: 0 dB *2 Power feed: Max. 1 A per connector Connector: RJ45 connector Connection Cable: Shielded Category 5 twisted pair cable (CAT5-STP) or greater Maximum Cable Distance: 1200 m (3937.01 ft)</p>
DS Link	<p>Connection Device: DS LINK of Power supply units Connector: RJ45 connector Connection Cable: Shielded Category 5 twisted pair cable (CAT5-STP) or greater Maximum Cable Distance: 5 m (16.4 ft)</p>
Analog Link	<p>Number of Connectors: 1 input, 1 output Connection Device: VX-3004F, VX-3008F, VX-3016F Connector: RJ45 connector Connection Cable: Shielded Category 5 twisted pair cable (CAT5-STP) or greater Maximum Cable Distance: 800 m (2624.67 ft)</p>
Control Input 1, 2	<p>16 inputs, no-voltage make contact input, open voltage: 24 V DC, short-circuit current: 2 mA Fault Detection System: Short circuit, Open circuit, Method: Voltage detect Connector: RJ45 connector Connection Cable: Shielded Category 5 twisted pair cable (CAT5-STP) or greater</p>
Emergency Control IN	<p>Input 2: Isolated voltage input, –24 to +24 V Connector: RJ45 connector Connection Cable: Category 5 twisted pair cable (CAT5) or greater</p>
VOX Function	<p>Threshold: –60 to 0 dB (1 dB steps) Hysteresis: 0 to +10 dB Hold time: 10 ms – 10 s Settable for each audio input</p>
Control Output 1, 2	<p>General outputs : 8 with CONTROL OUTPUT 1 Exclusive outputs : 3 with CONTROL OUTPUT 2 GENERAL FAULT, CPU FAULT, CPU OFF No-voltage make contact, electrical contact output, control current: 10 mA, withstand voltage: 28 V DC Connector: RJ45 connector Connection Cable: Shielded Category 5 twisted pair cable (CAT5-STP) or greater</p>

ATT/Control Output	16 outputs, no-voltage make contact, relay contact (NC, NO, C), control current: 2 mA to 5 A, withstand voltage: 125 V AC, 40 V DC Connector: Removable terminal block (12 pins) ... 4
Audio Input 1, 2, 3, 4	4 inputs Sensitivity: LINE: -20 dB* ² , MIC: -60 dB* ² LINE/MIC/ANC Sensor (changeable with setting software) Gain Control: Volume adjustable with volume control (internal front panel) $-\infty$ to 0 dB Input Impedance: 47 k Ω , electronically-balanced Frequency Response: 40 Hz to 20 kHz ± 1 dB (at DA CONTROL LINK, 0 dB output) Distortion: 1% or less (at DA CONTROL LINK, 0 dB output, 1 kHz) Signal to Noise Ratio: 60 dB or more (at DA CONTROL LINK, A-weighted) Phantom Power Supply: 24 V DC, can be set with setting software Connector: Removable terminal block (6 pins) ... 2
Digital Signal Processing	
Feedback Suppression Function (FBS)	7 filters (auto), Settable for each audio input and RS LINK (A/B)
Equalizer/Filter	3 bands for each audio input and RS LINK (A/B), 6 bands for each amplifier output Parametric equalizer: 20 Hz – 20 kHz, ± 15 dB, Q: 0.267 – 69.249 Filtering: High-pass filter 20 Hz – 20 kHz, 6 dB/oct, 12 dB/oct Low-pass filter 20 Hz – 20 kHz, 6 dB/oct, 12 dB/oct High shelving filter 6 – 20 kHz, ± 15 dB Low shelving filter 20 – 500 Hz, ± 15 dB Notch filter (amplifier output only) 20 Hz – 20 kHz, Q: 8.651 – 69.249 All-pass filter (amplifier output only) 20 Hz – 20 kHz, Q: 0.267 – 69.249 Horn equalizer (amplifier output only) 20 kHz, 0 to +18 dB (0.5 dB steps)
Compressor	Threshold: -20 to 0 dB (1 dB steps) Ratio: 1:1, 1.1:1, 1.2:1, 1.3:1, 1.5:1, 1.7:1, 2:1, 2.3:1, 2.6:1, 3:1, 4:1, 5:1, 7:1, 8:1, 10:1, 12:1, 20:1, ∞ :1 Attack time: 0.2 ms – 5 s Release time: 10 ms – 5 s Gain: $-\infty$ to +10 dB Knee type: hard knee, middle knee, soft knee
Delay	For each amplifier output, 0 – 2730 ms (0.021 ms steps)
ANC (Ambient Noise Control)	Amplifier output level control, Automatic sensor input reference level measuring, Sensor input reference level fine adjustment Maximum output signal level control: -15 to 0 dB Minimum output signal level control: -18 to -3 dB Sample time setting: 10 s, 20 s, 30 s, 1 min, 5 min Gain ratio setting: (Ambient noise: Output signal level) 6:3, 5:3, 4:3, 3:3, 3:4, 3:5, 3:6 Ambient noise measuring frequency setting: 20 Hz – 20 kHz, 3 points
Program Timer	Weekly program method Daily program: 50 events, 10 types Holiday program: 50 types
Time Adjustment	Control input, NTP
Speaker Line	16 channels, 2 Earth terminals Maximum Voltage/Current: 100 Vrms, 5 Arms Connector: Removable terminal block (17 pins) ... 2 Fault Detection System: Short circuit, Open circuit, Ground fault, Method: Impedance or End of line
Standby Amplifier Input/Output	Input: 1, Output: 1 Maximum Voltage/Current: 100 Vrms, 5 Arms Connector: Removable terminal block (2 pins) ... 2

Extension Amplifier Input/Output	Input: 1, Output: 1 Maximum Voltage/Current: 100 Vrms, 5 Arms Connector: Removable terminal block (2 pins) ... 2
Module* ³	Number of modules: 2 DA CONTROL LINK ... 2, DA OUTPUT LINK .. 2 (Used only when a power amplifier module is installed)
Indicators	POWER (green) ... 1, RUN (green) ... 1, EMERGENCY (red) ... 1, CPU OFF (red) ... 1, LAN A (green) ... 1, LAN B (green) ... 1, RS LINK A (green) ... 1, RS LINK B (green) ... 1 FAULT STATUS (yellow): GENERAL ... 1, UNIT ... 1, NETWORK ... 1, EMG MIC ... 1, FUSE ... 1, POWER ... 1, CPU ... 1, ZONE ... 16 AMPLIFIER: PEAK (red) ... 2, SIGNAL (green) ... 2, OPERATE (green) ... 2, POWER (green) ... 2
Operation	Fault Control Switch ...2 (ACK/RESET) Test Switch ...1 (LAMP TEST) Setting Switch: ID NUMBER, RESET, IMPEDANCE, Setting (internal front panel)
Operating Temperature	-5 to +45 °C (23 to 113 °F)
Operating Humidity	90% RH or less (no condensation)
Finish	Panel: Surface-treated steel plate, black, 30% glossy, paint
Dimensions	483 (w) x 132.6 (h) x 345 (d) mm (19.02" x 5.22" x 13.58")
Weight	8.1 kg (17.86 lb)

*¹ TOA's unique technology which makes it possible to transmit high-quality audio signals in real time over an IP network

*² 0 dB = 1 V

*³ Module: Digital power amplifier module, Line output module

Note: The design and specifications are subject to change without notice for improvement.

• Accessories

Rack mounting screw 5 x 12	4
CD (PC setting software)	1
Removable terminal plug (2 pins)	4
Removable terminal plug (4 pins)	1
Removable terminal plug (6 pins)	2
Removable terminal plug (12 pins)	4
Removable terminal plug (17 pins)	2
Ferrite cable clamp	2

2.4. VX-015DA Digital Power Amplifier Module 150 W

Power Source	31 V DC (operating range: 20 to 33 V DC) DC power in: M4 screw terminal, distance between barriers: 11 mm (0.43")
Amplification System	Class D
Power Consumption	1.3 W (standby mode), 14 W (no audio input), 40 W (1/8 rated output), 190 W (rated output) at 31 V DC, output voltage selection switch: 100 V
Rated Output Power	150 W (at 100 V line and min. impedance and max. capacitive load) 105 W (at 70 V line and min. impedance and max. capacitive load) 75 W (at 50 V line and min. impedance and max. capacitive load) (at AC Mains VX-3000DS or VX-3150DS: 187 to 253 V)
Output Voltage	100 V (70 V, 50 V: selectable)
Minimum Impedance Load	67 Ω (at 100 V line), 47 Ω (at 70 V line), 33 Ω (at 50 V line)
Maximum Capacitive Load	0.5 μ F
Number of Channels	1
Input	DA CONTROL LINK: Nylon connector (15 pins)
Output	DA OUTPUT LINK: Nylon connector (2 pins)
Frequency Response	40 Hz to 20 kHz: -5 to +1 dB (at 100 V line, 30 dB* output)
Distortion	1% or less (at 100 V line, rated output, 1 kHz)
Signal to Noise Ratio	100 dB or more (at 100 V line, A-weighted)
Operating Temperature	-5 to +45 °C (23 to 113 °F)
Operating Humidity	90% RH or less (no condensation)
Finish	Surface-treated steel plate
Dimensions	82.8 (w) x 91 (h) x 358.2 (d) mm (3.26" x 3.58" x 14.1")
Weight	1.3 kg (2.87 lb)

* 0 dB = 1 V

Note: The design and specifications are subject to change without notice for improvement.

• Accessories

DA control link cable	1
DA output link cable	1
DC fuse (10 A)	1

2.5. VX-030DA Digital Power Amplifier Module 300 W

Power Source	31 V DC (operating range: 20 to 33 V DC) DC power in: M4 screw terminal, distance between barriers: 11 mm (0.43")
Amplification System	Class D
Power Consumption	1.3 W (standby mode), 14 W (no audio input), 65 W (1/8 rated output), 375 W (rated output) at 31 V DC, output voltage selection switch: 100 V
Rated Output Power	300 W (at 100 V line and min. impedance and max. capacitive load) 210 W (at 70 V line and min. impedance and max. capacitive load) 150 W (at 50 V line and min. impedance and max. capacitive load) (at AC Mains VX-3000DS or VX-3150DS: 187 to 253 V)
Output Voltage	100 V (70 V, 50 V: selectable)
Minimum Impedance Load	33 Ω (at 100 V line), 23 Ω (at 70 V line), 17 Ω (at 50 V line)
Maximum Capacitive Load	0.5 μ F
Number of Channels	1
Input	DA CONTROL LINK: Nylon connector (15 pins)
Output	DA OUTPUT LINK: Nylon connector (2 pins)
Frequency Response	40 Hz to 20 kHz: -5 to +1 dB (at 100 V line, 30 dB* output)
Distortion	1% or less (at 100 V line, rated output, 1 kHz)
Signal to Noise Ratio	100 dB or more (at 100 V line, A-weighted)
Operating Temperature	-5 to +45 °C (23 to 113 °F)
Operating Humidity	90% RH or less (no condensation)
Finish	Surface-treated steel plate
Dimensions	82.8 (w) x 91 (h) x 358.2 (d) mm (3.26" x 3.58" x 14.1")
Weight	1.3 kg (2.87 lb)

* 0 dB = 1 V

Note: The design and specifications are subject to change without notice for improvement.

• Accessories

DA control link cable	1
DA output link cable	1
DC fuse (20 A)	1

2.6. VX-050DA Digital Power Amplifier Module 500 W

Power Source	31 V DC (operating range: 20 to 33 V DC) DC power in: M4 screw terminal, distance between barriers: 11 mm (0.43")
Amplification System	Class D
Power Consumption	1.3 W (standby mode), 16 W (no audio input), 100 W (1/8 rated output), 590 W (rated output) at 31 V DC, output voltage selection switch: 100 V
Rated Output Power	500 W (at 100 V line and min. impedance and max. capacitive load) 350 W (at 70 V line and min. impedance and max. capacitive load) 250 W (at 50 V line and min. impedance and max. capacitive load) (at AC Mains VX-3000DS or VX-3150DS: 187 to 253 V)
Output Voltage	100 V (70 V, 50 V: selectable)
Minimum Impedance Load	20 Ω (at 100 V line), 14 Ω (at 70 V line), 10 Ω (at 50 V line)
Maximum Capacitive Load	0.5 μ F
Number of Channels	1
Input	DA CONTROL LINK: Nylon connector (15 pins)
Output	DA OUTPUT LINK: Nylon connector (2 pins)
Frequency Response	40 Hz to 20 kHz: -5 to +1 dB (at 100 V line, 30 dB* output)
Distortion	1% or less (at 100 V line, rated output, 1 kHz)
Signal to Noise Ratio	100 dB or more (at 100 V line, A-weighted)
Operating Temperature	-5 to +45 °C (23 to 113 °F)
Operating Humidity	90% RH or less (no condensation)
Finish	Surface-treated steel plate
Dimensions	82.8 (w) x 91 (h) x 358.2 (d) mm (3.26" x 3.58" x 14.1")
Weight	1.4 kg (3.09 lb)

* 0 dB = 1 V

Note: The design and specifications are subject to change without notice for improvement.

• Accessories

DA control link Cable	1
DA output link Cable	1
DC fuse (30 A)	1

2.7. VX-300LO Line Output Module

Power Source	Supplied from the VX-3000 Frame (DA CONTROL LINK)
Current Consumption* ¹	Max. 2 mA (Current through DC POWER IN)
Input	DA CONTROL LINK: Connector (15 pins)
Audio Output* ¹	1 channel Output signal level: 0 dB* ² Adjustable range of the volume control knob: $-\infty$ to 0 dB Output method: 10 k Ω , transformer-balanced Applicable load impedance: 2 k Ω or more Frequency Response: 40 Hz – 20 kHz \pm 1 dB Distortion: 1 % or less (0 dB* ² output, 1 kHz) Signal to Noise Ratio: 60 dB or more Removable terminal block (3 pins)
Operating Temperature	0 to 40 °C (32 to 104 °F)
Operating Humidity	90% RH or less (no condensation)
Finish	Surface-treated steel plate
Dimensions	76 (w) x 39 (h) x 33.2 (d) mm (2.99" x 1.54" x 1.31")
Weight	56 g (0.12 lb)

*¹ When installed in the VX-3000 Frame.

*² 0 dB = 1 V

Note: The design and specifications are subject to change without notice for improvement.

• Accessories

DA control link Cable	1
Removable terminal plug (3 pins)	1
Mount base	2
Machine screw with washer M4 x 8.....	1

2.8. VX-3000PM Preamp Matrix Panel

Power Source	20 – 33 V DC, removable terminal block (2 pins)
Current Consumption	0.33 A at 33 V DC input 0.35 A at 24 V DC input
LAN A, B	<p>Number of Connectors: 2 (LAN A, LAN B)</p> <p>Network I/F: 100BASE-TX</p> <p>Network Protocol: TCP, UDP, ARP, ICMP, RTP, IGMP, HTTP</p> <p>Spanning tree Protocol: RSTP</p> <p>Audio Transmission System: TOA Packet Audio*¹</p> <p>Audio Encoding Method: PCM</p> <p>Audio Sampling Frequency: 48 kHz</p> <p>Audio Quantifying Bit Number: 16 bits</p> <p>Connection Device: VX-3004F, VX-3008F, VX-3016F, NX-300, VX-3000CT, VX-3000PM, Switching HUB</p> <p>Connector: RJ45 connector</p> <p>Connection Cable: Category 5 twisted pair cable (CAT5) or greater</p> <p>Maximum Cable Distance: 100 m (328.08 ft)</p>
Audio Input	<p>8 inputs</p> <p>Input Level:</p> <p>INPUT 1 – 4: –60 dB*²/–40 dB*²/–20 dB*²/0 dB*² selectable, input impedance 600 Ω, transformer-balanced</p> <p>INPUT 5, 6: –20 dB*², input impedance 10 kΩ, unbalanced</p> <p>INPUT 7, 8: 0 dB*², input impedance 10 kΩ, unbalanced</p> <p>Frequency Response: –60 dB*²: 200 Hz – 10 kHz, –2 dB ±3 dB –40 dB*²/–20 dB*²/0 dB*²: 100 Hz – 15 kHz, –2 dB ±3 dB</p> <p>Distortion: 1 % or less</p> <p>Signal to Noise Ratio: 60 dB or more</p> <p>Removable terminal block (6 pins x 2, 4 pins x 2)</p> <p>Only Input 1 is used in common with the front-mounted ø6.3 mm phone jack.</p>
Control Input	<p>20 channels, no-voltage make contact input, open voltage: 30 V DC, short-circuit current: 2 – 10 mA</p> <p>Connector: Removable terminal block (10 pins x 2, 12 pins x 2)</p>
Control Output	<p>Channels 1 – 5: relay (a contact), control current: 30 V DC, control current: 1 A</p> <p>Channels 6 – 10: open collector output (polarized), withstand voltage: 30 V DC, control current 100 mA</p> <p>Connector: Removable terminal block (10 pins) x 2</p>
Indicators	Signal indicator (green) ... 8, RUN (green) ... 1, LINK/ACT (green) ... 2
Volume Control	8 channels
Operation	Input level setting switch ... 1, IP address setting switch ... 1
Operating Temperature	0 to 40 °C (32 to 104 °F)
Operating Humidity	90% RH or less (no condensation)
Finish	<p>Panel: Pre-coated steel plate, black, 30 % glossy</p> <p>Volume control section cover: Acrylic resin, gray smoke</p>
Dimensions	482 (w) x 44 (h) x 292.4 (d) mm (18.98" x 1.73" x 11.51")
Weight	3.2 kg (7.05 lb)

*¹ TOA's unique technology which makes it possible to transmit high-quality audio signals in real time over an IP network

*² 0 dB = 1 V

Note: The design and specifications are subject to change without notice for improvement.

• Accessories

Rack mounting screw 5 x 12	4
Removable terminal plug (6 pins)	2
Removable terminal plug (4 pins)	2
Removable terminal plug (10 pins)	4
Removable terminal plug (12 pins)	2
Removable terminal plug (2 pins)	1

2.9. VX-3000CT Control Panel

Power Source	20 – 33 V DC, removable terminal block (4 pins)
Current Consumption	0.09 A at 33 V DC input 0.11 A at 24 V DC input
LAN A, B	Number of Connectors: 2 (LAN A, LAN B) Network I/F: 100BASE-TX Network Protocol: TCP, ARP, ICMP, HTTP Connection Device: VX-3004F, VX-3008F, VX-3016F, NX-300, VX-3000CT, VX-3000PM, Switching HUB Connector: RJ45 connector Connection Cable: Category 5 twisted pair cable (CAT5) or greater Maximum Cable Distance: 100 m (328.08 ft)
Indicators	POWER (green) ... 1, RUN (green) ... 1, LINK/ACT (green) ... 2, SIGNAL (green) ... 8, FAULT (yellow) ... 1, STATUS (green/yellow) ... 9, SELECT (green) ... 9
Volume Control	8 channels
Operation	Function key ... 9, Reset key ... 1, IP address setting switch ... 1
Operating Temperature	0 to 40 °C (32 to 104 °F)
Operating Humidity	90% RH or less (no condensation)
Finish	Panel: Surface-treated steel plate, black, 30 % glossy, paint Volume control section cover: ABS resin, gray smoke
Dimensions	482 (w) x 44 (h) x 315.2 (d) mm (18.98" x 1.73" x 12.41")
Weight	3 kg (6.61 lb)

Note: The design and specifications are subject to change without notice for improvement.

• Accessories

Rack mounting screw 5 x 12	4
Removable terminal plug (4 pins)	1

2.10. RM-200SF Fireman's Microphone

Power Source	24 V DC (operating range: 15 – 40 V DC, supplied from the VX-3000 system.)
Current Consumption	240 mA or less
Audio Output	0 dB*, transformer-balanced
Distortion	1% or less
Frequency Response	200 Hz – 15 kHz
Signal to Noise Ratio	55 dB or more
Microphone	Unidirectional dynamic microphone with talk key, AGC (ON/OFF switchable), Microphone element failure detectable by using a built-in oscillator
Chime	Built inside (PCM sound source), Monitoring available with a built-in speaker.
Volume Control	Microphone volume control, Monitor speaker volume control, Chime volume control (using the software)
Connection Cable	Main line: Shielded CPEV cable (each one pair of Audio line, Data line, Monitor/control line, and power supply line) or Shielded Category 5 twisted pair cable for LAN (CAT5-STP) or greater, M3 screw terminal
Maximum Cable Distance	800 m or 2624.67 ft (Total)
No. of Connectable RM-320F Units	Max. 4 units
Monitor Speaker	Built-in type
Operation	Emergency key, Function keys ... 3, CPU switch, Reset switch, Talk key
Indicator	Status indicators ... 3, Power indicator, Failure indicator, CPU indicator, Selection indicators ... 3, Microphone indicator, Broadcast status indicator
Operating Temperature	0 to 40°C (32 to 104°F)
Operating Humidity	35 to 80% RH (no dew condensation)
Finish	ABS resin, blueish gray (PANTONE 538 or its equivalent)
Dimensions	200 (w) x 215 (h) x 95 (d) mm (7.87" x 8.46" x 3.74") (including the Wall Mounting Bracket)
Weight	1.48 kg (3.26 lb)

* 0 dB = 1 V

Note: The design and specifications are subject to change without notice for improvement.

• Accessories

EMC clamp	1
Wall mounting bracket unit	1
4 x 25 tapping screw for wooden wall	2
M3.5 x 20 screw for electrical box	2

• Optional product

Fireman's Microphone Extension unit: RM-320F

2.11. RM-320F Fireman's Microphone Extension

Current Consumption	180 mA max. (in terms of RM-200SF)
Connection	Connection to RM-200SF by dedicated cable
Operation	Operation Function Keys ... 20
Indicator	Status indicator ... 20, Selection indicator ... 20
Finish	ABS resin, blueish gray (PANTONE 538 or its equivalent)
Dimensions	175 (w) x 215 (h) x 70 (d) mm (6.89" x 8.46" x 2.76")
Weight	700 g (1.54 lb)

Note: The design and specifications are subject to change without notice for improvement.

• Accessories

Wall mounting bracket	1
Wall mounting screw	2

2.12. RM-300X Remote Microphone

Power Source	24 V DC (operating range: 15 – 40 V DC, supplied from the voice evacuation frame) or DC input power supply connector (when the optional AD-246 AC adapter is used) Usable DC power supply plug: 5.5 mm (0.22") outer diameter, 2.1 mm (0.08") inner diameter, 9.5 mm (0.37") long, and non-polarity type.
Current Consumption	240 mA or less
Audio Output	0 dB*, 600 Ω, balanced
External Microphone Input	–40 dB*, 2.2 kΩ, unbalanced, ø3.5 mm phone jack (2P) for electret condenser microphone (phantom power supply: 3 V DC) –20 dB*, 4.7 kΩ, unbalanced, ø3.5 mm phone jack (2P) (AUX Input)
Distortion	1% or less
Frequency Response	100 Hz to 20 kHz
Signal to Noise Ratio	60 dB or more
Microphone	Unidirectional electret condenser microphone with AGC (ON/OFF selectable)
Chime	Built inside (PCM sound source), monitoring possible using monitor speaker
Level Controls	Microphone sensitivity control, Monitor speaker volume control, Chime (adjustable using the software)
Connection Cables	Main line: Shielded CPEV cable (1 pair of audio wire + 1 pair of data wire + 1 pair of monitor/control wire + 1 pair of power supply wire) or Shielded Category 5 twisted pair cable (CAT5-STP) or greater Branch line: Shielded Category 5 twisted pair cable (CAT5-STP) or greater, RJ45 connector
Maximum Cable Distance	1200 m (3937.01 ft)
No. of Connectable Extension units	Max. 7 units
Monitor Speaker	Built-in type
Operation	Function key, Emergency/all-zone emergency broadcast key, Talk key
Indicator	Power indicator, Failure indicator, Status indicator ... 10, Selection indicator ... 10, Emergency indicator, Broadcast status indicator, Microphone indicator
Operating Temperature	0 to 40 °C (32 to 104 °F)
Operating Humidity	35 to 80% RH (no condensation)
Finish	ABS resin, black, semi-gloss
Dimensions	190 (w) x 76.5 (h) x 215 (d) mm (7.48" x 3.01" x 8.46") (excluding microphone)
Weight	880 g (1.94 lb)

* 0 dB = 1 V

Note: The design and specifications are subject to change without notice for improvement.

• Optional products

Remote microphone extension: RM-210F

Wall mounting bracket: WB-RM200

Electret condenser microphone: WH-4000A, YP-M101, YP-M301 etc.

2.13. RM-210F Remote Microphone Extension

Power Source	Supplied from the optional RM-300X
AC Power Consumption	2.4 W (including power supply loss of the Emergency power panel) 0.4 W (standby, including power supply loss of the Emergency power panel)
Current Consumption	80 mA or less (increase in power input at the optional RM-300X)
Operation	Function key ... 10
Indicator	Status indicator ... 10, Selection indicator ... 10
Operating Temperature	0 to 40 °C (32 to 104 °F)
Operating Humidity	35 to 80% RH (no condensation)
Finish	ABS resin, black, semi-gloss
Dimensions	110 (w) x 76.5 (h) x 215 (d) mm (4.33" x 3.01" x 8.46")
Weight	350 g (0.77 lb)
Applicable unit	Remote microphone: RM-300X

Note: The design and specifications are subject to change without notice for improvement.

• Accessories

Connection cable (8 pins, 8 cm or 3.15") ...	1
Joint bracket A	2
Joint bracket B	1
Screw for joint bracket	12

• Optional product

Wall mounting bracket: WB-RM200

2.14. RM-200RJ Terminal Unit

Applied Voltage	40 V or less
Withstand Current	1 A
DC Voltage Monitoring Section	Monitor terminals: Terminal No. 7 (+) and Terminal No. 8 (-), Extinguish voltage: 14 V or less, Lighting voltage: 21 V or more, Indicator ON/OFF switchable
Connector	RJ45 connector x 1
Terminal Block	M3 screw terminal (10P), Barrier spacing: 6.62 mm (0.26")
Operating Temperature	0 to 40°C (32 to 104 °F)
Operating Humidity	35 to 80% RH (no condensation)
Finish	Surface-treated steel plate, black, paint
Dimensions	84 (w) x 116 (h) x 25.7 (d) mm (3.31" x 4.57" x 1.01")
Weight	250 g (0.55 lb)

Note: The design and specifications are subject to change without notice for improvement.

2.15. RM-500 Remote Microphone

Power Source	24 V DC (operating range: 15 – 33 V DC) Supplied from the voice evacuation frame (RJ45 connector) or the optional AD-246 AC adapter (DC input power supply connector) Usable DC power supply plug: 5.5 mm (0.22") outer diameter, 2.1 mm (0.08") inner diameter, 9.5 mm (0.37") long, polarized, center positive
Current Consumption	130 mA or less
Audio Output	0 dB*, balanced, RJ45 connector
AUX Input	1 channel, unbalanced, LINE/MIC (selectable with the DIP switch) LINE: –20 dB*, 10 k Ω , push-in terminal block MIC: –60 dB*, 2.2 k Ω , push-in terminal block
Control Input	1 channel, no-voltage make contact inputs, open voltage: 33 V DC, short-circuit current: 10 mA , push-in terminal block
Control Output	1 channel, open collector output, withstand voltage: 30 V DC, control current: 35 mA, push-in terminal block
Distortion	1% or less
Frequency Response	100 Hz to 20 kHz
Signal to Noise Ratio	60 dB or more
Microphone	Unidirectional electret condenser microphone
Chime	Uses the built-in sound sources of the main system unit (one of them selectable by the main system settings)
Level Control	Microphone volume control, AUX volume control
RM Link	Shielded Category 5 twisted pair LAN cable (CAT5-STP), RJ45 connector Maximum cable distance: 1200 m (3937.01 ft) (when powered by the optional AD-246 AC adapter)
External Equipment Connection Cable	Solid copper wire: \varnothing 0.4 – \varnothing 1.1 mm (AWG 28 – 17)
Operation	Numeric key x 10, Left/right selection key x 2, F1/F2 key x 2, ALL key x 1, Clear key x 1, Talk key x 1, AUX key x 1
Indicator	LCD display: 3" (255 x 160 dots), with backlight Indicator: Talk indicator (green), Microphone indicator (green)
Operating Temperature	0 to 40 °C (32 to 104 °F)
Operating Humidity	90% RH or less (no condensation)
Finish	ABS resin, black, paint
Dimensions	224 (w) x 47.2 (h) x 136 (d) mm (8.82" x 1.86" x 5.35") (excluding microphone)
Weight	620 g (1.37 lb)

* 0 dB = 1 V

Note: The design and specifications are subject to change without notice for improvement.

• Accessories

Zip tie 2

• Optional products

Wall mounting bracket: WB-RM500

AC adapter: AD-246

2.16. WB-RM500 Wall Mounting Bracket

Finish	Stainless steel
Dimensions	146 (w) x 113 (h) x 23.9 (d) mm (5.75" x 4.45" x 0.94")
Weight	170 g (0.37 lb)

Note: The design and specifications are subject to change without notice for improvement.

• Accessories

4 x 25 tapping screw (for direct wall mounting) 2
M4 x 20 machine screw (for mounting to the switch box) 2

2.17. VM-300SV End Of Line Unit

Power Source	Supplied from the VX-3000 system
Power Consumption	0.2 W
Speaker Line Input (CN1)	Screw connector, Applicable cable diameter: AWG 24 – AWG 19
Contact Output (CN2)	Connected to the emergency contact input of VX-3004F/3008F/3016F Connection cable: Twisted pair cable (shielded type is recommended) Screw connector, Applicable cable diameter: AWG 24 – AWG 19
Speaker Line	Max. load: 100 W Note: applicable only for 100 V speaker line
Dimensions	70 (w) x 18 (h) x 45 (d) mm (2.76" x 0.71" x 1.77")
Weight	20 g (0.04 lb)

Note: The design and specifications are subject to change without notice for improvement.

Traceability Information for Europe

Manufacturer:
TOA Corporation
7-2-1, Minatojima-Nakamachi, Chuo-ku, Kobe, Hyogo,
Japan

Authorized representative:
TOA Electronics Europe GmbH
Suederstrasse 282, 20537 Hamburg,
Germany

URL: <https://www.toa.jp/>